

Construction Environmental Management Plan

Site C Clean Energy Project

Revision 12.1: September 20, 2024

TABLE OF CONTENTS

Revision History..... **3**

GLOSSARY **14**

1.0 Introduction..... **19**

 1.1 BC Hydro 19

 1.2 Project Overview and Description 19

 1.3 BC Hydro Environmental Responsibility Policy 20

 1.4 Environmental Assessment 20

 1.5 Environmental Assessment Conclusion 21

2.0 Environmental Management Roles and Responsibilities..... **22**

 2.1 BC Hydro 24

 2.2 Independent Environmental Monitor 25

 2.3 Contractors..... 26

 2.4 Environmental Protection Plans 28

 2.5 Environmental Incidents 32

 2.6 CEMP Review and Revision 33

3.0 Orientation, Training and Tailboard Meetings..... **35**

 3.1 Environmental Overview Training 35

 3.2 Pre-work Orientation and Tailboard Meetings 35

4.0 Environmental Specifications..... **37**

 4.1 Air Quality Management 37

 4.2 Blasting Management..... 41

 4.3 Contaminated Sites Management..... 43

 4.4 Erosion Prevention and Sediment Control Management 45

 4.5 Fisheries and Aquatic Habitat Management..... 49

 4.6 Fuel Handling and Storage Management..... 59

 4.7 Groundwater Protection..... 61

 4.8 Hazardous Waste Management 62

 4.9 Heritage Resources Management 63

 4.10 Ice Management..... 65

 4.11 Noise and Vibration Management..... 66

 4.12 Soil Management, Site Restoration and Revegetation 68

 4.13 Spill Prevention and Response 70

 4.14 Surface Water Quality Management 77

 4.15 Vegetation and Invasive Plant Management 81

 4.16 Waste Management 82

 4.17 Wildlife Management 85

4.18 Restricted Activity and Work Avoidance Zones	94
5.0 Pre- and Post- Construction Surveys and Monitoring	95
5.1 Vegetation and Wildlife Surveys	95
5.2 Post- Construction Monitoring.....	95
6.0 Qualified Environmental Professionals.....	96
7.0 Appendices	97

List of Appendices

- Appendix A Smoke Management Plan
- Appendix B Air Quality Monitoring Program
- Appendix C Construction Communications Plan
- Appendix D Aboriginal Group Communication Plan
- Appendix E Acid Rock Drainage and Metal Leachate Management Plan
- Appendix F Water Licence Leaves to Commence Construction Process
- Appendix G Mitigation, Management and Monitoring Plans
- Appendix H Soil Management, Site Restoration and Revegetation Plan
- Appendix I Erosion and Sediment Control Plan
- Appendix J Erosion and Sediment Control Program
- Appendix K Invasive Weed Mitigation and Adaptive Management Plan
- Appendix L Western Toad Management Procedure
- Appendix M Weekly Environmental Monitoring Report Template
- Appendix N Bird Nest Survey Guidance

Revision History

Version	Date	Comments
Draft	10-17-2014	Draft
Draft	02-26-2015	Draft
Rev 0	05-19-2015	Final Plan
Rev 1	06-05-2015	Final Plan, Revision 1
Rev 2	02-02-2016	<p>Non-Material Revisions</p> <ul style="list-style-type: none"> • Clarified requirements to identify applicable permits and authorizations (S. 2.4) • Added requirement to include a table detailing revision history (S. 2.4) • Clarified reporting requirements and timeframes for submitting reports (S. 2.4.2 and 2.4.3) • Added requirement to include a rationale for edits to EPPs (S. 2.4.4) • Clarified the requirements for incident reporting (S. 2.5) • Added provision for BC Hydro to require additional mitigation measures if ambient air quality does not meet the provincial objectives (S. 4.1) • Revised the restriction on blasting near bat hibernacula (S. 4.2) • Deleted reference to obsolete MWLAP Field Guide (S. 4.6) • Added requirement to include a noise management program (S. 4.11) • Updated the language for 85th Avenue industrial lands noise (S. 4.11) • Updated requirements for contents of spill kits and that “spills of any volume are an Environment Incident”. (S. 4.13) • Added controls for application of road salt (S. 4.14) • Buffer around nests if a bird builds or occupies a nest in an active construction zone changed to a minimum 5 m (S. 4.17) • These revisions are not material within the meaning of Section 2.6 because: <ul style="list-style-type: none"> • the revisions will not result in a reduction of any monitoring or reporting requirements • the revisions will not result in the deletion or reduction of an environmental specification • the revisions will not otherwise make an adverse effect more likely, nor become more adverse and be significant.

Version	Date	Comments
Rev 3/4	07-08-2016 / 07-26-2016	<p data-bbox="657 268 933 296"><u>Non-Material Revisions</u></p> <ul style="list-style-type: none"> <li data-bbox="657 327 1344 359">• Revised Table numbering and the Table of Contents <li data-bbox="657 363 1422 512">• Clarified roles and responsibilities, IEM duties, lines of communication, reporting requirements, reformatted for greater clarity, and provided further definition of terms (Glossary, S. 2 and sub-sections, 2.4.3, 2.4.4, 2.5, 2.6, 4.5, 4.13 and 4.17) <li data-bbox="657 516 1425 636">• Added reference to the Environmental Assessment for the project and added background related to the Environmental Assessment findings, conclusions and requirements for greater clarity (S. 1.2, 1.4 and 1.5.) <li data-bbox="657 640 1403 760">• Added reference to and a summary of the BC Water License Process required for dam and reservoir construction to provide greater background and clarity (S. 1.2 and Appendix F). <li data-bbox="657 764 1414 884">• Added reference to the requirement for, and a summary of separate mitigation, management and monitoring plans required by the Environmental Assessment Certificate as applicable to construction (S. 1.5 and Appendix G). <li data-bbox="657 888 1338 919">• Clarified requirements for inclusion in EPPs (S. 2.4). <li data-bbox="657 924 1419 1043">• Revised text for clarity related to environmental monitoring requirements, added “The QEP will define in each EPP the work activities that fall into the above risk categories.” (S. 2.4.1). <li data-bbox="657 1047 1386 1100">• Revised text associated with incident reporting timelines and what must be reported immediately (S. 2.5). <li data-bbox="657 1104 1425 1157">• Updated environmental orientation and tailboard sections to clarify project requirements (S. 3.1 and 3.2) <li data-bbox="657 1161 1403 1323">• Revised to provide clarity related to requirement for contingency sediment and erosion control supplies, required mitigation measures for water balance mitigation and added “unless otherwise authorized in a permit or approval” (S. 4.4). <li data-bbox="657 1327 1425 1564">• Added detail related to hydro acoustic monitoring and mitigation, readily biodegradable hydraulic fluid requirements, clarity that coffer dam work is included, improved clarity for fish salvage requirements, minimum flow requirements to better reflect project requirements and added greater clarity for guideline references, added “unless otherwise authorized in a permit or approval (S. 4.5). <li data-bbox="657 1568 1321 1661">• Used wording from BMP to better describe desired equipment condition and added “unless otherwise authorized in a permit or approval (S. 4.6). <li data-bbox="657 1665 1414 1757">• Revised to better reflect requirements for EPPs related to use of groundwater and associated licensing requirements (S. 4.7). <li data-bbox="657 1761 1377 1881">• Revised and reformatted Soil Management, Site Restoration, and Revegetation requirements to provide greater clarity and better reflect project requirements (S. 4.12)

Version	Date	Comments
		<ul style="list-style-type: none"> • Revised to provide greater clarity related to spill contingency supply, training, emergency response and external reporting requirements, added “spills of any volume are an Environmental Incident” (S.4.13) • Revised to provide clarity related to concrete and concrete product and water diversion mitigation and associated guidelines, required water management details to be provided for structures capable of retaining water, added that Technical Specifications for some contracts provide additional details for how to manage acid rock drainage and metal leachate, and added “unless otherwise authorized in a permit or approval” (S. 4.14). • Relocated rare plant mitigation elements from S. 4.17 to S. 4.15 and adding clarity for work associated with invasive plant and pest management to be in accordance with applicable guidelines (S. 4.15). • Revised to provide further clarity related to the requirement for animal proof containers (S. 4.16). • Revised for greater clarity related to data reporting, buffer zones, mapping updates, speed limit sign posting, mitigation measure requirements to better reflect project requirements, added survey and monitoring requirement clarity for grouse leks, added clarity for education of workers related to identification of wildlife dens, provided clarity on what “adjacent to” means, and, added “after considering site-specific information” to QEP role in establishing buffers (S.4.17) • Added Appendix H – Soil Management, Site Restoration, and Revegetation Plan that augments and adds to previous measures for clarity (S.4.12) • Added Appendix I – Water Management, Erosion and Sediment Control Plan, to augment measures prescribed in CEMP (S. 4.4) and compliance with the Erosion and Sediment Control Plan required by a S34(1) Order from the BC Environmental Assessment Office. <p>These revisions are not material within the meaning of Section 2.6 because:</p> <ul style="list-style-type: none"> • the revisions will not result in a reduction of any monitoring or reporting requirements • the revisions will not result in the deletion or reduction of an environmental specification • the revisions will not otherwise make an adverse effect more likely, nor become more adverse and be significant.
Rev 5	02-19-2019	<p><u>Material Revisions that require consultation with regulatory agencies and Indigenous Groups, per Section 2.6 of the CEMP</u></p> <ul style="list-style-type: none"> • Revised the QEP requirements for overseeing the handling and movement of contaminated soil. The proposed edit removes the requirement for a Contaminated Sites

Version	Date	Comments
		<p>Approved professional (CSAP) to be involved in the handling and storage of contaminated soils. The handling of these soils is regulated under the Contaminated Sites Regulation and given the nature of the reasonably expected contaminants on the Site C project the involvement of a CSAP would not be required under this Regulation. The proposed edit makes the professional qualification requirements more appropriate for this kind of routine activity (S. 4.3)</p> <ul style="list-style-type: none"> • Revised text to allow for the use of non-native seed mixes, together with native seed mixes, during initial site revegetation. The revisions are intended to improve effectiveness of erosion control measures at site while continuing to meet the project's long-term objective of achieving a sustainable native species ecosystem (S. 4.12; Appendix H, S 3.0) • Revised text to allow for mechanical clearing in riparian areas where worker safety prohibits manual tree falling and vegetation removal methods, and as addressed in a site specific prescription endorsed by a QEP. The rationale for the safety exemption must be documented in the prescription (S. 4.5) • Revised the length of sorbent boom sock required in vehicular spill kits. This proposed edit allows for spill kits to contain absorbent boom socks that are commercially more readily available and also provides a significant space reduction in the volume of the spill kits as the existing CEMP requirement requires very long sorbent boom socks that occupy a large volume (S. 4.13)
Rev 5.1	04-19-2019	<p><u>Non-Material Revisions</u></p> <ul style="list-style-type: none"> • Added Appendix J - Erosion and Sediment Control Program (S. 4.4) • Added Appendix K - Invasive Weed Mitigation and Adaptive Management Plan (S. 4.15) • Added Appendix L - Western Toad Management Procedure(S. 4.17) • Added Appendix M – Weekly Environmental Monitoring Report Template (S.2.4.2) • New label for Figure 1 – Relationship between Regulators, the IE, IEM, Contractors and BC Hydro (S 2.0) • Revised BC Hydro responsibilities regarding noise monitoring (S.2.1) • Additional Contractor Environmental Responsibilities including QEP author and endorsement of proposed alternatives to environmental requirements, QEP management of ESC measures, QEP sign-off on corrective actions, QEP wildlife sweeps, providing BC Hydro with data including GIS and/or shapefiles associated with any newly discovered environmentally sensitive features such as bear dens, bird nests etc. and additional environmental flagging / poster requirements (S 2.3) • Clarification on relationship between QEP environmental

Version	Date	Comments
		<p>monitors and environmental technicians plus reference to weekly environmental monitoring report template (Appendix M) (S.2.3.1)</p> <ul style="list-style-type: none"> • Clarification on purpose of Component Management Plans (CMPs) (S 2.4) • Provided examples of high environmental risk activities such as in-stream work (S.2.4.1) • Expanded weekly environmental reporting requirements and provided a new template (Appendix M) (S 2.4.2) • Expanded completion reporting requirements (S2.4.2) • Added additional description of the EPP review process (S2.4.4) • Added Section 2.4.5 - Environmental Non-Conformance and Non-Compliance • Added provision that allows BCH to provide the contractor with updated training materials and minimum content information (S 3.1) • Added additional mitigation options for preventing dust generating when hauling loads (S4.1) • Added requirement to have a Qualified Professional who is also a CPESC and referenced and appended the Erosion and Sediment Control Program Document as Appendix J of the CEMP (S 4.4) • Modified Ordinary High Water Mark to align with glossary definition (S 4.4) • Added reference to FLNRO and MOTI guidance documents referencing applicable industry standards for bridge drainage (S 4.5) • Added requirement to list all equipment used for work that may have come in contact with aquatic invasive species (S 4.5) • Added clarity around containment design and where containment is and is not required (S 4.6) • Added mitigation measures to define vehicle and equipment inspection frequency and to re-inforce use of spill trays under stationary vehicles and equipment (S 4.13) • Added provisions to ensure contractors train all employees on proper waste handling techniques and ensure that all waste bins are available prior to the start of intrusive works and include highly visible signage showing acceptable contents for each bin. Removed allowance to bury used tires in an RSEM (S 4.16) • Clarified pre-disturbance den search requirements and reporting, role of QEP in den buffer establishment and removal, and updated terrestrial wildlife least risk timing windows. Updated Table 5, reference list and Figure 3 to reflect updated 'Sharp-tailed Grouse monitoring decision tree'. Also added new requirements for western toad salvage and relocation via procedure in new Appendix L (S 4.17) • Clarified flagging and other boundary demarcation requirements, including improved communication around

Version	Date	Comments
		flagging types (S 4.18) <ul style="list-style-type: none"> • These revisions are not material within the meaning of Section 2.6 because: <ul style="list-style-type: none"> • the revisions will not result in a reduction of any monitoring or reporting requirements • the revisions will not result in the deletion or reduction of an environmental specification • the revisions will not otherwise make an adverse effect more likely, nor become more adverse and be significant.
Rev 6	July 15, 2019	<u>Non-Material Revisions</u> <ul style="list-style-type: none"> • Clarification provided in section 2.6 regarding CEMP review by contractors • Clarification provided in section 4.4 regarding removal of stumps for construction of access roads • New Subsurface Mulching section included in Section 4.4 consistent with Rev 2 of the Vegetation Clearing and Debris Management Plan • Clarification provided in Section 4.5 regarding Peace River back channels • Include an updated bird nest survey protocol as appendix N and referenced in section 4.17 • Clarification on amphibian set back buffers provided in section 4.17 • Clarification on contractor amphibian salvage monitoring requirements provided in section 4.17 • Clarification on contractor site restoration monitoring requirements provided in Section 5.2 • These revisions are not material within the meaning of Section 2.6 because: <ul style="list-style-type: none"> • the revisions will not result in a reduction of any monitoring or reporting requirements • the revisions will not result in the deletion or reduction of an environmental specification • the revisions will not otherwise make an adverse effect more likely, nor become more adverse and be significant. <u>Material Revisions that require consultation with regulatory agencies and Indigenous Groups, per Section 2.6 of the CEMP</u> <ul style="list-style-type: none"> • Added text to describe fording of watercourses/streams for works of short duration under the direction of a QEP (S. 4.5)

Version	Date	Comments
		<ul style="list-style-type: none"> • Added text regarding the management naturally occurring woody debris (S. 4.5) • Clarified noise mitigation measures (S. 4.11) • Clarified regulatory agency consultation requirement regarding buffer set-backs (S. 4.17)
Rev 6.1	December 12, 2019	<p><u>Non-Material Revisions</u></p> <ul style="list-style-type: none"> • Updated Appendix A – Smoke Management Plan to reflect regulatory changes, specifically the September 2019 Open Burning Smoke Control Regulation. Detailed information on updates is provided in the updated Plan (Rev 3). <p>This revision is not material within the meaning of Section 2.6 because:</p> <ul style="list-style-type: none"> • the revision will not result in a reduction of any monitoring or reporting requirements • the revision will not result in the deletion or reduction of an environmental specification • the revision will not otherwise make an adverse effect more likely, nor become more adverse and be significant.
Rev 7	September 4, 2020	<p><u>Non-Material Revisions</u></p> <ul style="list-style-type: none"> • Updated Section 2.4 to include requirement for mandatory environmental holdpoints providing a summary of work activities that will not proceed prior to other actions occurring first • Updated Section 2.5 regarding the requirement to report in writing on a weekly basis when implementing corrective actions that take longer than 5 days to implement • Updated Section 4.2 with Portage Quarry blasting restrictions and vicinity to bat hibernacular • Updated Section 4.3 regarding pole removal in environmentally sensitive areas • Updated Section 4.13 to be consistent with environmental incident reporting • Hyperlink references updated throughout document and appendices • Updated Appendix A Smoke Management Plan • Updated Appendix B Air Quality Monitoring Plan • Updated Appendix E Acid Rock Drainage and Metal Leachate Management Plan • Updated Appendix H Restoration / Revegetation Plan • Updated Appendix K Invasive Weed Mitigation and Adaptive Management Plan • Updated Appendix N Bird Nest Survey Guidance <p>These revisions are not material within the meaning of Section 2.6 because:</p> <ul style="list-style-type: none"> • the revisions will not result in a reduction of any monitoring or reporting requirements • the revisions will not result in the deletion or reduction of an environmental specification

Version	Date	Comments
		<ul style="list-style-type: none"> the revisions will not otherwise make an adverse effect more likely, nor become more adverse and be significant.
Rev 8.0	September 14, 2021	<p><u>Non-Material Revisions</u></p> <p>Updated Appendix A – Smoke Management Plan</p> <ul style="list-style-type: none"> Updated to amend the ‘period for igniting piles of unlit vegetative debris’ and ‘period for adding unlit vegetative material to ignited piles’ within the MSSZ to be consistent with Open Burning Smoke Control Regulation (B.C. Reg 152/2019). Updated key contacts for notification, specifically contacts for the following: Ministry of Environment and Climate Change Strategy, RCMP Hudson Hope Detachment, RCMP Fort St John Detachment, City of Fort St John, Fort St John Fire Department, District of Taylor and Fire Department, District of Hudson’s Hope, Hudson’s Hope Fire Department, Chetwynd Fire Department, BC Wildfire Service, Northern Health, BC Hydro Public Relations and Communications. <p>These revisions are not material within the meaning of Section 2.6 because:</p> <ul style="list-style-type: none"> the revision is correcting a typographical error to align with BC Regulations the revisions will not result in a reduction of any monitoring or reporting requirements the revisions will not result in the deletion or reduction of an environmental specification the revisions will not otherwise make an adverse effect more likely, nor become more adverse and be significant.
Rev 9.0	January 17, 2022	<p><u>Material Revisions that require consultation with Regulatory Agencies and Indigenous Groups, per Section 2.6 of the CEMP:</u></p> <p>Updated Appendix E - Acid Rock Drainage / Metal Leachate Management Plan</p> <ul style="list-style-type: none"> Material Revisions require consultation with regulatory agencies and Indigenous Nations, per Section 2.6 of the CEMP. The below revisions have been made after consultation with regulatory agencies and Indigenous Nations as required: <ul style="list-style-type: none"> Updated Sections 6.1.1, 6.1.2, 7.0, 7.2.2, 7.3.2, 7.4.1, 7.5.2, and 7.5.3 to reflect revisions to the water quality sampling program based on lessons learned during construction to date in accordance with an adaptive management approach, and areas of redundancy with other sections of the CEMP Updated Table 2 end-of-pipe limits to reflect a site-specific toxicological assessment undertaken

Version	Date	Comments
Rev 10.0	March 9, 2022	<p data-bbox="657 268 1412 325"><u>Material Revisions that require consultation with Regulatory Agencies and Indigenous Groups, per Section 2.6 of the CEMP:</u></p> <ul data-bbox="706 357 1429 1060" style="list-style-type: none"> • Clarified that debris and deleterious substances must be prevented from entering watercourses “without effective isolation” (S. 4.5) • For Spill and Prevention Response, revised requirement to state that activities that involve potentially harmful or toxic substances such as oil, fuel, antifreeze, and concrete will follow approved practices and consider Develop with Care 2014: Environmental Guidelines for Urban and Rural Land Development in British Columbia (BCMOE 2014) “or mitigation measures described herein.” (S. 4.13) • Revised text to require that all works involving the use of concrete, cement, mortars, and other Portland cement or lime-containing construction materials (concrete) will not deposit, directly or indirectly, sediments, debris, concrete, concrete fines, wash or contact water into or about any watercourse “without appropriate isolation” (S. 4.14). • Added requirements for use of mechanical or chemical means to safely and effectively isolate all deleterious concrete related works from any water within or entering into any watercourse of stormwater system (S 4.14) • Added definition of effective isolation for cast-in-place concrete and grouting in fish-bearing waters (S 4.14). <p data-bbox="657 1092 933 1123"><u>Non-Material Revisions</u></p> <p data-bbox="657 1134 1429 1260">Added Section 4.5 to clarify that unless otherwise authorized in a permit or approval, in-stream temporary structures must be decommissioned and removed within the construction season that they are deemed to be no longer required (bold added)</p> <p data-bbox="657 1291 1396 1354">These revisions are not material within the meaning of Section 2.6 because:</p> <ul data-bbox="706 1396 1429 1575" style="list-style-type: none"> • the revisions will not result in a reduction of any monitoring or reporting requirements • the revisions will not result in the deletion or reduction of an environmental specification • the revisions will not otherwise make an adverse effect more likely, nor become more adverse and be significant.

Version	Date	Comments
Rev 10.1	April 6, 2022	<p data-bbox="659 264 938 296"><u>Non-Material Revisions</u></p> <ul data-bbox="706 327 1425 541" style="list-style-type: none"> • Rescinded material revisions introduced in Rev 10, dated March 9, 2022 pending further regulatory review • Added the below bolded language to S 4.5 regarding fording: “A temporary ford may be used multiple times at a given location for clearing and debris management below the reservoir 5 year beach line or as authorized in an applicable permit or approval.” <p data-bbox="659 579 1393 638">These revisions are not material within the meaning of Section 2.6 because:</p> <ul data-bbox="706 680 1425 865" style="list-style-type: none"> • the revisions will not result in a reduction of any monitoring or reporting requirements • the revisions will not result in the deletion or reduction of an environmental specification • the revisions will not otherwise make an adverse effect more likely, nor become more adverse and be significant.
Rev 11.0	October 10, 2022	<p data-bbox="659 898 1414 957"><u>Material Revisions that require consultation with Regulatory Agencies and Indigenous Nations, per Section 2.6 of the CEMP:</u></p> <ul data-bbox="659 1003 1430 1843" style="list-style-type: none"> ○ Clarified terms related to use of non-toxic chemical barriers in water column to prevent mixing with deleterious substances. These revisions are a clarification of Material Revisions consulted on for Rev. 10.0 issued on March 9, 2022. • Updated text to indicate that debris and deleterious substances must be prevented from entering watercourses “without effective isolation” or use of a non-toxic chemical barrier (S. 4.5) • Revised text to require that all works involving the use of concrete, cement, mortars, and other Portland cement or lime-containing construction materials (concrete) will not deposit, directly or indirectly, sediments, debris, concrete, concrete fines, wash or contact water into or about any watercourse “without appropriate isolation” or use of a non-toxic chemical barrier (S. 4.14). • Added requirements for use of mechanical or chemical means to safely and effectively isolate or create an effective barrier that will prevent deleterious substances from entering into any watercourse, stormwater system or water column prevent S 4.14) • Added definition of effective isolation and non-toxic chemical barrier for cast-in-place concrete and grouting in fish-bearing waters (S 4.14). ○ Revised Appendix H, Soil Management, Site Restoration and Revegetation Plan. Please refer to Appendix H for detail.

Version	Date	Comments
		<p><u>Non-Material Revisions</u></p> <ul style="list-style-type: none"> ○ Revised Air Quality Management Plan to add mitigation measures (such as dust suppression on roads) at Hudson’s Hope Shoreline Protection work area and along the haul route from Portage Mountain Quarry to the Hudson’s Hope Shoreline Protection work area if project-related construction activity is associated with elevated particulate matter readings above the BC ambient air quality objectives (S 4.1). Note: these updates have been implemented since August 2021. ○ Revised Appendix B, Air Quality Monitoring Program to add details on monitoring at the Hudson’s Hope Shoreline Protection. Please see Appendix B for detail. ○ Updated Section 5.14 Waste Management to allow for burial of clean (e.g., free of other wastes like, plastic, wood, etc) and cured waste concrete below the reservoir provided it is covered with minimum 1 m thick organize cover layer which does not exceed 455 m. <p>These revisions are not material within the meaning of Section 2.6 because:</p> <ul style="list-style-type: none"> • the revisions will not result in a reduction of any monitoring or reporting requirements • the revisions will not result in the deletion or reduction of an environmental specification the revisions will not otherwise make an adverse effect more likely, nor become more adverse and be significant
Rev 12.0	October 23, 2023	<p><u>Material Revisions that require consultation with Regulatory Agencies and Indigenous Nations, per Section 2.6 of the CEMP:</u></p> <ul style="list-style-type: none"> • Revisions to Appendix E, Acid Rock Drainage and Metal Leachage Management Plan. Please refer to Appendix E for details.
Rev 12.1	September 20, 2024	<p><u>Non-Material Revisions</u></p> <p>Revised Section 4.16 Waste Management / General Construction Wastes to clarify requirements for burial of concrete on BC Hydro owned land.</p> <p>These revisions are not material within the meaning of Section 2.6 because:</p> <ul style="list-style-type: none"> • the revisions will not result in a reduction of any monitoring or reporting requirements

Version	Date	Comments
		<ul style="list-style-type: none"> the revisions will not result in the deletion or reduction of an environmental specification the revisions will not otherwise make an adverse effect more likely, nor become more adverse and be significant

GLOSSARY

Term	Definition
Aboriginal Groups	<ul style="list-style-type: none"> Blueberry River First Nations Dene Tha' First Nation Doig River First Nation Duncan's First Nation Fort Nelson First Nation Halfway River First Nation Horse Lake First Nation Kelly Lake Métis Settlement Society McLeod Lake Indian Band Métis Nation British Columbia Prophet River First Nation Saulteau First Nations West Moberly First Nations
CEMP	Construction Environmental Management Plan
Construction	<p>Any activity associated with building the Site C project, including but not limited to:</p> <ul style="list-style-type: none"> clearing site preparation quarrying excavation material handling and processing material placement concrete works road and bridge building site reclamation
Dam Site Area	The grey area shown in Figure 2
Environmental Features Map	<ul style="list-style-type: none"> GIS spatial data that identifies known environmental, heritage and cultural features and environmentally sensitive areas This data will be updated as additional information is collected.
Environmental Incident	An event, act or omission that is, or has the potential to cause, a violation of any of the Environmental Requirements. Examples of Environmental Incidents include, but are not limited to:

Term	Definition
	<ul style="list-style-type: none"> • Spills of oil, fuel, hazardous chemicals • Unauthorized discharges of deleterious substances into fish-bearing water bodies • Unauthorized alteration, disruption, or destruction of aquatic or terrestrial habitat • Alteration of, or damage to, heritage or archaeological resources • Fires related to construction activities • Unauthorized release of air pollutants
Environmental Monitor	A Qualified Environmental Professional who observes and reports on construction activities in relation to the requirements under the applicable EPP
Environmental Requirements	<ul style="list-style-type: none"> • The Environmental Specifications • The conditions included in the Environmental Assessment Certificate for the Project (BC Environmental Assessment Office, 2014) • The conditions included in the decision statement issued by the Minister of Environment of Canada (CEAA, 2014) • The permits, authorizations and approvals for the Project issued by regulatory agencies • Statutory requirements
Environmental Specifications	The specifications set out in Section 4 of this CEMP
Environmentally Sensitive Area	Location of an environmental feature of importance, including but not limited to: <ul style="list-style-type: none"> • Watercourse crossing • Location of rare or endangered plant • Sensitive ecosystem sites (wetlands, tufa seeps, marl fens, grasslands, and old-growth forests) • Raptor nest site • Nest or den site of rare or endangered wildlife • Culturally important feature • Rare plant sites • Active bear, wolf, fox or coyote den sites
EPP	Environmental Protection Plan
Important Wildlife Areas	Wildlife habitat areas that many animals use around the same time each year, including, but not limited to: <ul style="list-style-type: none"> • wetlands • snake hibernacula • bat hibernacula • sharp-tailed grouse leks • beaver lodges, dams and food caches • active furbearer and large carnivore den sites • active bird nests • mineral licks • habitat used by ungulates for winter range • amphibian breeding sites and migration routes
Independent	A person, retained by BC Hydro, with professional qualifications and demonstrated experience and knowledge, who provides information regarding

Term	Definition
Engineer	the design and construction of the Project under the direction of the Comptroller of Water Rights
Independent Environmental Monitor	A person, retained by BC Hydro, with professional qualifications, demonstrated experience and knowledge of environmental monitoring for construction projects in BC, including experience working in a third party role, who will summarize the environmental reports prepared by BC Hydro and its contractors and report monthly to BC Hydro, the Independent Engineer, the BC Environmental Assessment Office, the Canadian Environmental Assessment Agency, the Comptroller of Water Rights, and any other regulatory agencies as directed from time to time by BC Hydro, on the compliance of the construction activities with the Environmental Requirements
Invasive Plants	A noxious weed designated by weed control regulation in British Columbia to be a noxious weed, and includes the seeds of the noxious weed, as well as invasive species identified under the Peace River Regional District Invasive Plant Program
Ordinary High Water Mark	The visible high water mark of any river, stream, wetland or other body of water where the presence and action of the water are so common and usual and so long continued in all ordinary years as to mark upon the soil of the bed of the river, stream, wetland or other body of water a character distinct from that of the banks, both in vegetation and in the nature of the soil itself. (BC Ministry of Environment, 2014)
Project Activity Zone	Area within which the Project components will be found or will occur, but not including existing transportation infrastructure that will be used without modification to transport materials or personnel required for the Project. (BC Hydro 2013)
Qualified Environmental Professional (QEP)	An applied scientist or technologist who specializes in a relevant applied science or technology including, but not limited to: agrology, forestry, biology, engineering, geomorphology, geology, hydrology, hydrogeology or landscape architecture. A Qualified Environmental Professional must be a member in good standing registered with the appropriate professional organization in British Columbia, and acting under that association's Code of Ethics and subject to disciplinary action by that association. He or she must also be someone who, through demonstrated suitable education, experience, accreditation and knowledge relevant to the particular matter, may be reasonably relied on to provide advice within his or her area of expertise. (BC Environmental Assessment Office, 2014)
The Project	Site C Clean Energy Project
Raptors	Birds of prey including eagles, hawks, owls and falcons
RISC	BC Integrated Land management Bureau Resources Information Standards Committee
RSEM	Relocated Surplus Excavated Material
Sensitive Wildlife	Wildlife species that require specific habitats or habitat features which could be affected by Project activities within or adjacent to the habitat or feature Wildlife species that are known to be intolerant of human caused disturbance during critical times of the year (e.g. breeding season, winter season)

Term	Definition
Stop Work Procedure	A procedure to be provided in each EPP that is to be followed in the event that a construction activity must be stopped for non-compliance with an EPP. The procedure must be developed in accordance with Section 2.4.3 of this CEMP
Work Avoidance Zone	Areas where construction activities are prohibited, or restricted to specified activities

References

BC Environmental Assessment Office, 2014. Site C Clean Energy Project Environmental Assessment Certificate, Schedule B. Access via:

http://a100.gov.bc.ca/appsdata/epic/documents/p371/d38033/1413310195243_2bQVJ9jQcGC_4X6vQzLvMGnsQ6CmV2F3sM8QyMCTp5cJQmp4ddLcR!-351597226!1413309200763.pdf

BC Hydro, 2013. Site C Clean Energy Project Environmental Impact Statement, Volume 1. Access via:

http://www.ceaa.gc.ca/050/documents_staticpost/63919/92870/Volume_1-Executive_Summary-Introduction.pdf

BC Ministry of Environment, 2014. Instream Works Glossary. Access via:

<http://www.env.gov.bc.ca/wld/instreamworks/glossary.htm#h>

Canadian Environmental Assessment Agency, 2014. Decision Statement Issued Under Section 54 of the *Canadian Environmental Assessment Act, 2012* to British Columbia Hydro and Power Authority for the Site C Clean Energy Project. Access via:

<http://www.ceaa-acee.gc.ca/050/documents/p63919/100567E.pdf>

1.0 Introduction

1.1 BC Hydro

BC Hydro is a Crown corporation owned by the Province of British Columbia. BC Hydro's mandate is to generate, manufacture, conserve, purchase, and sell electricity to meet the needs of its customers. BC Hydro serves 95 per cent of B.C.'s population, delivering electricity safely and reliably to approximately 1.9 million customers.

As the largest electric utility in British Columbia, BC Hydro operates an integrated system with 31 hydroelectric facilities and three thermal generating plants, totaling approximately 12,000 MW of installed generating capacity. The hydroelectric facilities provide over 95 per cent of the total electricity generated and are located in the Peace, Columbia, and Coastal regions of B.C.

BC Hydro owns and operates two hydroelectric generation facilities on the Peace River that together account for greater than 30% of the capacity of the electrical power generation facilities in B.C. The existing facilities are operated as part of a coordinated system to allow BC Hydro to respond to seasonal and hourly changes in electricity demand.

W.A.C. Bennett Dam was completed in 1968 and is located 168 km upstream of the Alberta border. The Peace Canyon Dam was constructed in 1976 approximately 23 km downstream of the W.A.C. Bennett Dam near the town of Hudson's Hope. Water discharged from the G.M. Shrum Generating Station or released from discharge facilities (spillways, low level outlets) at W.A.C. Bennett Dam flows directly into the Dinosaur Reservoir. Water discharged from the Peace Canyon Dam and Generating Station enters the Peace River and flows downstream past the Site C dam site.

1.2 Project Overview and Description

The Site C Clean Energy Project (the Project) will be the third dam and generating station on the Peace River. The Project will provide up to 1,100 MW of capacity and about 5,100 GWh of energy each year to the province's integrated electricity system.

The components of the Project are:

- Dam, generating station, and spillways
- Reservoir
- Hudson's Hope shoreline protection berm
- Substation and transmission lines to Peace Canyon Dam
- Highway 29 realignment
- Quarried and excavated construction materials
- Worker accommodation
- Road and rail access

This Construction Environmental Management Plan (CEMP) applies to all activities undertaken in construction of the Project. The Project is as described in Schedule A of the Environmental Assessment Certificate #14-02 issued in respect of the Project.

Specific Project components related to dam and reservoir construction are subject to BC Provincial Water Licensing that includes the requirement to obtain specific Leaves to Commence Construction (LCCs) from the Comptroller of Water Rights (CWR) as described in Appendix F.

1.3 BC Hydro Environmental Responsibility Policy

The Project will be constructed and operated to meet the objectives of BC Hydro's Environmental Responsibility Policy which currently states:

"Consistent with our purpose to provide reliable power at low cost for generations, BC Hydro is committed to producing, acquiring, delivering and consuming electricity in an environmentally, socially and financially responsible manner.

We recognize that our energy system causes both positive and negative impacts on the environment and on those with whom we share public resources. Conservation is a key means to avoid negative environmental impacts. Where negative impacts cannot be avoided, we will work to minimize and offset them and sustain resources over the long term.

Specifically, BC Hydro will:

- *Meet environmental requirements defined by legislation, regulation, government directives, and other environmental standards that apply to BC Hydro*
- *Perform beyond environmental requirements where it makes sound business sense*
- *Make decisions about environmental risk and opportunity in accordance with our values in a structured and systematic way to balance competing objectives*
- *Continually improve our environmental performance and our environmental management systems exercising due diligence*
- *Work to reduce historic environmental impacts*
- *Develop and foster an electrical energy conservation culture in B.C. that leads to customers choosing to make a dramatic and permanent reduction in electricity consumption*
- *Seek products, services and new supplies of energy that take into account environmental responsibility*
- *Work cooperatively with stakeholders and First Nations on resource use, management, and conservation to increase public benefits from affected resources*
- *Publicly report on our environmental performance."*

1.4 Environmental Assessment

The Site C Project underwent a cooperative Environmental Assessment in accordance with the BC Environmental Assessment Act (BCEAA) and the Canadian Environmental Assessment Act (CEAA). The environmental assessment of the Project focused on 22 valued components (VCs), or aspects of the biophysical and human setting that are considered important by Aboriginal groups, the public, the scientific community, and government agencies. In the Environmental Impact Statement (EIS), valued components were categorized under five pillars: environmental, economic, social, heritage and health. For each VC, the assessment of the potential effects of the Project components and activities during construction and operations was based on a comparison of the biophysical and human environments between the predicted future conditions with the Project, and the predicted future conditions without the Project.

Potential adverse effects on each VC are described in the EIS along with technically and economically feasible mitigation measures, their potential effectiveness, as well as specific follow-up and related commitments for implementation. If a residual effect was found on a VC, the effect was evaluated for significance. Residual effects were categorized using criteria related to direction, magnitude, geographic extent, context, level of confidence and probability, in accordance with the EIS Guidelines.

Existing baseline conditions, potential effects of the Project and proposed measures to mitigate potential effects on Fish and Fish Habitat, Vegetation and Ecological Communities, Wildlife Resources and Heritage Resources are described in the Project's EIS, Volume 2, Sections 12, 13 and 14, and Volume 4 Section 32, respectively.

The assessment found that the effects of the Project will largely be mitigated through careful, comprehensive mitigation programs and ongoing monitoring during construction and operations. The EIS indicates that the Project is unlikely to result in a significant adverse effect for most of the valued components. However, a determination of a significant effect of the Project was found on four VCs: Fish and Fish Habitat, Wildlife Resources, Vegetation and Ecological Communities, and Current Use of Lands and Resources for Traditional Purposes.

1.5 Environmental Assessment Conclusion

On October 14, 2014, the Provincial Ministers of Environment and of Forests, Lands and Natural Resource Operation decided that the Project is in the public interest and that the benefits provided by the Project outweigh the likely risks of significant adverse environmental, social and heritage effects. The Ministers have issued an Environmental Assessment Certificate setting conditions under which the Project can proceed.

Further, on November 25, 2014, The Minister of Environment of Canada issued a Decision Statement confirming that, while the Project has the potential to result in some significant adverse effects, the Federal Cabinet has concluded that those effects are justified in the circumstances. The Decision Statement sets out the conditions under which the Project can proceed.

Condition 70 of the EAC Document requires that BC Hydro prepare specific mitigation, management and monitoring plans ("Plans") to satisfy associated requirements. Appendix G provides an overview level description of the plans as they pertain to construction and associated links where the plans can be viewed. Additional and relevant information is found within these plans that may require referral in development of site specific Environmental Protection Plans in accordance with this CEMP.

2.0 Environmental Management Roles and Responsibilities

Environmental management is the responsibility of BC Hydro, the Independent Environmental Monitor (IEM), BC Hydro's contractors and their qualified environmental professionals and environmental monitors. Compliance with environmental requirements will involve ongoing discussions with the regulatory agencies. The relationships and associated lines of communication between these various parties for the construction phase of the Project are shown in Figure 1. Specific roles and responsibilities are described in the section below.

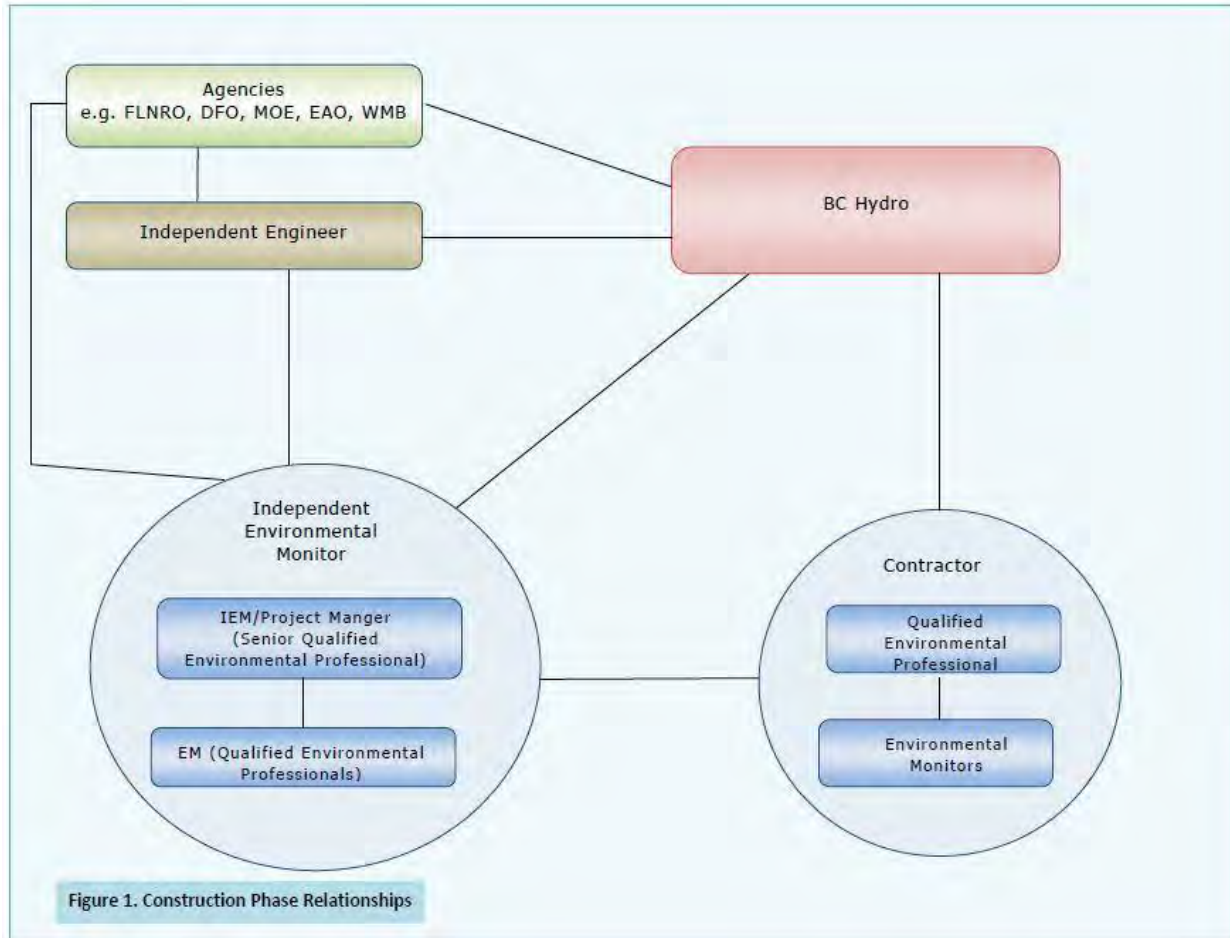

Figure 1 – Relationship between Regulators, the Independent Engineer (IE), IEM, Contractors and BC Hydro

Roles and responsibilities of BC hydro and contractors are summarized in Table 1. More detail is provided in the sub-sections of Section 2.

Table 1 Summary of Roles and Responsibilities

Entity	Role and Responsibility
BC Hydro	Develop and maintain the CEMP
	Lead communication with stakeholders and Aboriginal groups
	Review contractor's EPP's
	Audit compliance with the requirements of EPPs
	Report to regulators and the IEM
	Report environmental incidents internally and to Aboriginal Groups
	Monitor air quality, noise and vibration except where, or in addition to where, contractors are required to monitor these variables as per their EPP or Safety Plan
	Communicate with the IEM on Project progress and compliance with Environmental Requirements
	Prepare monthly reports in accordance with EAC requirements, and provide these monthly reports to the IEM to communicate Project progress and compliance with Environmental Requirements, and provide these monthly reports to the IE during construction under the Water License.
Contractors	Appoint a QEP to prepare EPP(s) and manage and supervise Environmental Monitors
	Appoint Environmental Monitor(s)
	Ensure that all construction activities are conducted in compliance with the applicable EPP
	Ensure that their workers and subcontractors are appropriately trained and supervised
	Ensure that their Supervisors and Environmental Monitors attend an environmental overview training workshop.
	Ensure that tailboard meetings take place
	Inform BC Hydro should the conditions differ materially from those anticipated under the applicable EPP
	Undertake corrective and preventative measures in response to any non-conformance with an EPP
	Ensure that all permits necessary to undertake the construction activities have been obtained
	Report environmental information to BC Hydro
	Immediately report every Environmental Incident as described in S. 2.5
	Investigate the cause of every Environmental Incident and implement preventive and corrective actions
Independent Environmental Monitor	Review and comment on the CEMP providing recommendations to the Comptroller of Water Rights for acceptance where required by the Comptroller of Water Rights (CWR) (see Appendix F).
	Audit and review compliance of construction activities with the Environmental Requirements
	Report directly to regulators on the compliance of the construction activities with the Environmental Requirements during construction. Where requested by the CWR, report to the CWR and the IE (See Appendix F).
	Review and comment on contractors' EPPs. Where a specific condition of the CWL Process (See Appendix F), verify that EPP's adequately address environmental mitigation requirements and provide comments to indicate acceptance or if revisions are warranted prior to construction proceeding.

2.1 BC Hydro

BC Hydro will:

- Develop and maintain the Construction Environmental Management Plan (CEMP) that specifies the requirements for Environmental Protection Plans (EPPs)
- Communicate with the Contractors' personnel and the IEM related to compliance with the CEMP and related component plans
- Lead communication with regulatory agencies, local governments, interested and potentially affected Aboriginal Groups, and public stakeholders, including property owners and local residents
- Audit compliance with the requirements of the applicable EPP including, but not limited to:
 - Conformance of construction activities to the Environmental Requirements
 - The effectiveness of implemented mitigation measures
 - That implemented mitigation measures are maintained for as long as those mitigation measures are required
 - That applicable permits and approvals have been obtained
 - That spill response and emergency equipment and procedures are implemented and maintained
 - Worker training and supervision
 - Response to environmental incidents
 - Waste records
- Prepare and submit monthly reports to the Independent Environmental Monitor, EAO and CEAA within 45 days following the reporting period. Submit the monthly reports to the IE during construction under the Water License. Monthly reports are to summarize:
 - Project progress
 - EMP and EPP submissions
 - Permits issued by provincial and federal agencies
 - Reports submitted by contractor Environmental Monitors
 - Results of the BC Hydro field inspections
 - Environmental incidents and applicable corrective action
 - Compliance of construction activities with the Environmental Requirements
- Monitor air quality, noise and vibration except where, or in addition to where, Contractors are required to monitor these variables as per their EPP or Safety Plan

2.2 Independent Environmental Monitor

BC Hydro will retain an Independent Environmental Monitor (IEM). The IEM will have authority and responsibility to audit and review:

- Compliance of construction activities with the Environmental Requirements
- BC Hydro's auditing of contractor's environmental monitoring as described in Section 2.1
- BC Hydro monthly environmental reports as described in Section 2.1
- Contractor environmental monitoring as described in Sections 2.3.1
- Contractor environmental monitoring reports as described in Sections 2.3.1
- Environmental incident reports as described in Section 2.5
- The content and frequency of environmental overview training and pre-work orientation and tailboard meetings as described in Section 3

The IEM will:

- Develop, and submit to BC Hydro and the Comptroller of Water Rights, a work plan that describes the activities that the IEM will undertake, including but not limited to:
 - The frequency of on-site inspection of construction activities
 - The QEPs from the IEM's staff, their positions and their responsibilities, to be involved in the on-site inspection activities
 - The QEPs from the IEM's staff, their positions and their responsibilities, to be involved in the review of documents
- Communicate with BC Hydro, Contractors QEPs, and the Contractors EM during audit activities and in response to review of plans and reporting related to compliance
- Communicate with the Independent Engineer during construction to coordinate their activities to provide information to the Comptroller of Water Rights for proper regulation of the construction of the works; and
- Report directly to the Independent Engineer, the executive director of the Environmental Assessment Office, the President of the Canadian Environmental Assessment Agency, the Comptroller of Water Rights, and any other regulatory agencies as directed from time to time by BC Hydro, on the compliance of the construction activities with the Environmental Requirements during construction

2.3 Contractors

Contractors must:

- Appoint Qualified Environmental Professionals to develop EPPs in accordance with Section 2.4
- Ensure that all of the contractor's construction activities are carried out in accordance with an EPP
- Appoint Qualified Environmental Professional(s) to:
 - Manage and supervise the contractor's Environmental Monitors
 - Communicate with BC Hydro and the IEM regarding compliance with the CEMP and related component plans
 - Author and endorse any request for clarification, or proposed alternatives to, the Environmental Requirements
 - Communicate to external agencies where required by legislation or specific permit requirements (e.g. compliant with spill reporting regulation)
 - Design, implement and oversee maintenance of all erosion prevention and sediment control measures
 - Manage the invasive weed management program
 - Sign-off on the corrective actions for non-conformance and/or non-compliances providing their professional assurance on the adequacy of these mitigation measures
 - Conduct bird nest and den sweeps as appropriate ahead of intrusive works in newly accessible work areas. Such sweeps shall be documented and signed-off via the weekly environmental monitoring report
- Ensure that their workers and subcontractors are appropriately trained, supervised and have the necessary experience and competency to implement the requirements of the EPPs
- Ensure that their Supervisors and Environmental Monitors attend an environmental overview training workshop as described in Section 3.1 of this CEMP
- Ensure that the tailboard meetings described in Section 3.2 of this CEMP take place
- Inform BC Hydro should the conditions of the environment or construction practices change materially from that as anticipated under the applicable EPP
- Undertake corrective and preventative measures in response to non-conformance with the EPP, and ensure that such measures have been implemented in a timely manner
- Ensure that all permits necessary to undertake the construction activities have been obtained, either by BC Hydro or by the contractor, prior to commencing such construction activities
- Provide BC Hydro with any data, including GIS and/or shape files related to newly discovered environmentally sensitive features such as dens, bird nest etc
- Provide BC Hydro with photos and site mapping which includes a legend for all flagging used within the Contractors work site to delineate different environmental sensitive features. Informative posters shall be deployed in the field showing different flagging types and the features they are delineating
- By January 30 of each year report to BC Hydro the following information:

- The quantity of each type of fuel consumed at the Project site during the preceding year
- The production through put for the preceding year of on-site processes that contribute to greenhouse gas emissions

2.3.1 Environmental Monitors

Contractors must appoint Environmental Monitors who will monitor construction activities with respect to compliance with the applicable EPPs. Environmental Monitors shall be Qualified Environmental Professionals. Environmental Technicians can complete the below environmental monitoring tasks for which they are qualified provided they are under the supervision of an Environmental Monitor.

The responsibilities of the Environmental Monitors are:

- Conducting monitoring of construction in accordance with the applicable EPP
- Communicate with BC Hydro and the IEM onsite representatives during auditing activities as it relates to compliance
- Providing technical assistance on environmental matters to construction personnel
- In consultation with the contractor's Qualified Environmental Professional, providing recommendations for modifying and/or improving environmental mitigation measures, as necessary
- Documenting construction activities, mitigation measures, and environmental incidents by field notes and photographs
- Taking field measurements and conducting analyses in accordance with the EPP
- Completing inspection checklists for each monitoring site visit consistent with the monitoring requirements in the EPP
- In consultation with the Qualified Environmental Professional, identifying and providing recommendations for resolving potential problems to the contractor and BC Hydro
- Preparing, signing and submitting to BC Hydro and the Independent Environmental Monitor weekly Environmental Monitoring Reports during construction periods in accordance with the relevant EPPs and as per the Weekly Environmental Monitoring Report Template (Appendix M)
- Preparing and submitting to BC Hydro and the Independent Environmental Monitor an Environmental Completion Report at the end of construction activities that describes compliance with the applicable EPPs, and any reportable environmental incidents, including the responses to those incidents, that may have occurred in the course of work

2.4 Environmental Protection Plans

An EPP will be prepared by Qualified Environmental Professionals with the expertise relevant to the construction activities covered by the EPP.

In developing the EPP, the QEP will take into consideration:

- Any guidance issued by regulatory authorities with respect to the Environmental Requirements or Environmental Specifications that may be applicable
- The Environmental Requirements and the Environmental Specifications
- Contract requirements

The EPP will include:

- A clear statement of objectives
- A description of the particular construction activities and location to which the EPP applies
- A table including mandatory environmental hold-points providing a summary of work activities that will not proceed prior to other actions (e.g., site assessments, communication with BC Hydro, etc.) occurring first
- Mapping at a suitable scale, including identification of any environmentally sensitive areas
- A description of the potential environmental effects and safety hazards that relate to environmental management for the specific activities and locations of the work
- Detailed site or activity-specific mitigation measures and how they will be implemented
- Provisions for working in extreme cold temperatures where applicable
- Identification of applicable permits and authorizations
- A description of worker qualifications and training requirements pertaining to implementation and monitoring of the requirements within the EPP
- Description of how the contractor will comply with the conditions of those permits and authorizations
- A table detailing revision history

If a Contractor's work requires multiple EPPs, that each contain similar activity specific requirements, Component Management Plans (CMP) may be prepared to address activity-specific rather than site-specific measures. If a Contractor elects to utilize one of more CMP(s), each CMP must explain how the Contractor will satisfy the Environmental Requirements for each activity and be used in conjunction with one or more EPPs to meet the CEMP requirements. CMPs shall be reviewed, approved and managed in the same manner as EPPs for the purposes of this CEMP.

2.4.1 Environmental Monitoring

Each EPP will provide for environmental monitoring of construction activities sufficient to reliably determine whether the construction activities are being conducted in compliance with the EPP. The minimum requirements for environmental monitoring are as follows; with percentages relating to time the Environmental Monitors expected to be present during specific work components:

- Minor environmental risk activities – less than 10% of the activity must be monitored
- Low environmental risk activities –10% to 40% of the activity must be monitored
- Moderate environmental risk activities – 40% to 90% of the activity must be monitored
- High environmental risk activities (e.g., in-stream work, activity within active animal den

buffers, etc.) – 100% of the activity must be monitored

The QEP will define in each EPP the work activities that fall into the above risk categories.

Each EPP must provide the following details with respect to monitoring:

- The type and frequency of observations and data collection, methodologies to be employed, and protocols to be followed, including, but not limited to:
 - Regular inspection of:
 - Sediment and erosion control measures
 - RSEM areas and management measures required for Acid Rock Drainage/Metal Leaching
 - Construction equipment on site for leaks or spills
 - Bulk fuel storage facilities, including monitoring of fuel deliveries and transfers
 - Adequacy of the emergency response and spill containment and recovery equipment, and spill response training programs
 - Construction activities to evaluate appropriate implementation of mitigation measures
 - Construction waste management programs
 - Water quality monitoring upstream and downstream of construction areas including RSEMs, including measurement of common parameters (e.g., pH, temperature, turbidity, dissolved oxygen, conductivity, total suspended solids), especially during construction (e.g., concrete pours) in the vicinity of watercourses
 - Monitoring the quality of point discharges relative to the applicable requirements

2.4.2 Reporting

Weekly Environmental Report

Contractors shall prepare a weekly environmental report that shall be signed by the appropriate QEP attesting that the work covered by the weekly report was completed in compliance with the EPP and where it was not in compliance, the weekly report will provide a summary of the non-compliance and associated corrective action. Each weekly report will provide, at minimum, a description of:

- Construction activities
- Environmental monitoring activities
- Identified environmental issues and corresponding mitigation measures implemented
- Results of any testing of environmental attributes
- Results of any inspections and field verifications required by this CEMP
- Any events of non-compliance with EPP requirements and associated corrective action plan(s) and status of each past and current corrective action item
- Photographs (accompanied by identifying information such as date, location) documenting

construction activities, environmental issues, and corresponding mitigation measures.

Weekly reports shall be submitted to BC Hydro within one week of the reporting period and shall follow the weekly report template provided in Appendix M.

Each EPP will provide that, for any monitoring data collected, sampling conducted, or analyses performed the following information shall be reported, in a format acceptable to BC Hydro:

- The place, date and time of sampling
- The analyses that were performed and the dates they were performed
- The analytical techniques, methods, or procedures used in the analyses
- The names of the persons who collected and analyzed each sample and
- The results of the analyses

Environmental Completion Report

Within 30 days of the completion of the construction activities covered by the EPP the Contractor shall submit to BC Hydro an Environmental Completion Report that shall include, but not limited to:

- A summary of construction activities
- A summary of environmental monitoring activities during construction
- A description of environmental incidents and issues encountered during construction, and the management and mitigation measures used to resolve the issues
- A summary of relevant permits and approvals, including how conditions of permits and approvals were met (for example, Wildlife Act reporting requirements; Water Sustainability Act reporting requirements)
- Representative site photographs
- Verification that the site covered by the EPP is safe, restored/revegetated as required, that all deficiencies and spills have been rectified
- Sign-off by the appropriate Qualified Environmental Professional(s)

2.4.3 Stop Work

Every EPP must provide for a Stop Work Procedure. Every Stop Work Procedure must:

- Identify the person(s) employed by the contractor with the authority to direct that a construction activity that is being conducted in breach of the EPP must be immediately stopped (the contractor's designated person)
- The direct contact information for that (those) person(s)
- Provide that the contractor's designated person, the Independent Environmental Monitor, and BC Hydro each have the authority to stop a construction activity that is being conducted in breach of an EPP, in accordance with the Stop Work Procedure

The EPP must provide that any order to stop work that is issued shall include a description of the nature of the non-compliance, including a description of the activity, the location, the time and the element of the EPP that is being breached. When an order to stop work is issued, the Environmental Monitor must also immediately notify BC Hydro and the Independent Environmental Monitor.

Once work has been stopped due to a stop work order, it must not re-start until the Contractor's EM, Contractor's QEP and BC Hydro are satisfied that the work will be compliant with the EPP.

Within five working days of any order to stop work being issued, the contractor must provide to BC Hydro and the Independent Environmental Monitor a written environmental incident investigation report that meets the requirements of Section 2.5 Environmental Incidents.

2.4.4 EPP Review and Revision

The Qualified Environmental Professional that prepares an EPP is responsible for ensuring that it meets the requirements of this CEMP. In addition, each EPP must be provided to BC Hydro at least 30 days prior to commencement of the construction activities covered by that EPP.

BC Hydro Subject Matter Experts (SME) will review the EPP and apply the following grading:

- C1 – Accepted
- C2 – Proceed Except as Noted and Re-Submit
- C3 – Do Not Proceed – Re-Submit as Noted
- C4 – Rejected

Once graded the Site C Environmental Submissions Co-ordinator will communicate the EPP review grade to the BC Hydro Representative who will subsequently communicate to the Contractor.

The IEM will also be offered an opportunity to review and comment on each EPP and the Contractor shall address these comments in addition to BC Hydro comments. Where an EPP is required to support an application for a Leave to Construct (LTC) from the Independent Engineer, the IEM will often provide a detailed review of that EPP and either through the review process or via a condition in the LTC, may require revisions to the EPP before some or all of the work covered by the EPP will be approved by the LTC.

The Contractor will not perform any element of the Work at the Site until the applicable EPP(s) has been submitted for Review and returned with an endorsement confirming that BC Hydro has no objection to the applicable EPP.

Any revisions to an EPP must be provided to BC Hydro prior to construction activities covered by the revised EPP. BC Hydro and the IEM may review the revised EPP and may require the QEP, the contractor, or both, to provide a rationale for the revision, and to demonstrate that the revised EPP complies with the requirements of this CEMP prior to commencement of the construction activities covered by that revised EPP.

EPPs may require revisions as a result of amendments of the CEMP or in response to relevant changes, for example, changes in:

- Project design
- Construction procedures and methods
- Construction schedule
- Site conditions

2.4.5 Environmental Non-Conformance and Non-Compliance

Environmental regulatory non-compliances, which are not corrected immediately, may result in BC Hydro completing the corrective actions on behalf of the Contractor. Any corrective measures which are completed by BC Hydro on behalf of the Contractor will be charged back to the Contractor. The Contractor must be pro-active and responsive when a potential non-conformance or non-compliance is identified by their own Environmental staff, BC Hydro's Representative, the IEM and/or Agency inspectors and develop a corrective action plan immediately. Non-compliances which are not addressed immediately may lead to cancellation of all or a portion of the Contractor's Work covered by the relevant EPP(s) and/or non-payment for the same. Corrective actions must be designed and implemented by a QEP who shall sign-off on their adequacy and that they address the root cause of the non-conformance and/or non-compliance.

2.5 Environmental Incidents

In the event of an Environmental Incident contractors must:

- Immediately report all available information regarding the Environmental Incident (e.g., Location, nature of incident, potentially affected environment, scale of incident (minor, moderate, severe), etc.) to:
 - The appropriate authority if required by statute to be reported
 - BC Hydro and
 - The Independent Environmental Monitor
- Within five working days of an Environmental Incident reported to Regulators or an order to stop work, provide to BC Hydro and the Independent Environmental Monitor a written environmental incident investigation report that includes appropriate photo documentation and describes the:
 - Nature of the incident
 - Approximate magnitude and duration of the incident
 - Area or habitat affected
 - Environmental resources affected
 - Results of any sample analysis taken in conjunction with the incident (e.g., water samples)
 - Root cause(s) of the incident
 - Immediate actions taken
 - Preventive and corrective actions to control or limit the activity causing the incident, including a time frame for implementation
 - Communications held with the contractor's employees and with BC Hydro
 - Communications with the Independent Environmental Monitor or regulatory agencies
- Reports will be available to regulators upon request
- Contractors must implement the identified preventive and corrective actions in the time frame specified

- The contractor's QEP must confirm in a written report to BC Hydro that the identified preventive and corrective actions have been taken within five working days of implementation of each action
- For clarity, when corrective actions take longer than 5 days to implement the contractor must provide weekly written report updates detailing progress on implementation of corrective actions

In the event of an Environmental Incident BC Hydro must:

- Report internally in accordance with corporate reporting policies and procedures
- Report externally where required by applicable legislation (e.g. Spill Reporting Regulation)
- Ensure the IEM is notified of the incident, in the event the Contractor failed to do so
- Notify Aboriginal Groups as required

2.6 CEMP Review and Revision

During construction of the Project, at least once every 12 months, and more often as may be required, BC Hydro will review this CEMP.

Further information may become available as detailed design progresses and as the results of pre-construction surveys are received. Information may also be received from contractors, Aboriginal Groups, the public and regulatory agencies. During construction, corrective or preventative actions may be taken in response to incidents. It may be beneficial to take this information into account in a revision of this CEMP.

A material revision of this CEMP is one which would be relevant to the question of whether an adverse effect is more likely to occur, or become more adverse, and be significant, and would include, in particular:

- A reduction of monitoring or reporting requirements
- Deletion of an environmental specification, or making a specification less stringent

If BC Hydro proposes to make a material revision of this CEMP, to the extent practical in the circumstances, BC Hydro will provide draft text of the proposed material revision for review and comment to: i) the executive director of the Environmental Assessment Office (the "Executive Director"), ii) the President of the Canadian Environmental Assessment Agency (the "President of the Agency"), iii) BC Ministry of Environment, BC Ministry of Forests Lands and Natural Resource Operations, Environment Canada, Natural Resources Canada, and iv) Aboriginal Groups who would potentially be affected by the proposed revision.

The period of time provided for review and comment on a proposed material revision will depend on the nature or urgency of the revision and the relative interests or jurisdiction of government agencies and of the rights and relative interests of potentially affected Aboriginal group, and any legal requirement to consult. If BC Hydro proposes material revisions to the body of this CEMP, a copy of the CEMP showing the proposed revisions will be provided. If BC Hydro proposes to materially revise an appendix, a revised copy of the appendix only will be provided.

BC Hydro may also provide an opportunity to review and provide comments on proposed material CEMP revisions to those contractors who are required to amend EPPs. The opportunity to review and provide comments will be given utilizing the communication protocols provided for in applicable

contracts.

An opportunity to review and provide comments will not be provided for proposed revisions that would not be material, for example, revisions to:

- Correct typographical or grammatical errors
- Reflect changes that are necessary as a result of other amendments, for example, updating page numbers, updating the version number or date of the CEMP, updating the glossary, etc.
- Revise or update citations to references, guidance documents or statutory documents
- Add monitoring or reporting requirements
- Add an environmental specification or make an existing specification more stringent

Each time the CEMP is revised, all EPPs must be reviewed by a QEP and revised, where necessary.

3.0 Orientation, Training and Tailboard Meetings

The activities identified in this section shall be conducted as part of the Project to provide a basis for informing contractors, BC Hydro, and their crews of environmental requirements specified in this CEMP.

3.1 Environmental Overview Training

Prior to the start of field activities, Field Crew Supervisors, Qualified Environmental Professionals and Environmental Monitors shall attend an environmental overview and training workshop. The workshop will include, but is not limited to, the following topics, as applicable to the construction activities to be undertaken:

- Briefings and copies of Schedule B (Table of Conditions) of the EAC and all Environmental and Safety Management Plans identified in Schedule B that are relevant to works
- The requirements of the EPPs
- Potential effects of the Project and proposed mitigation measures
- Environmental Requirements
- Requirements of the CEMP
- The roles and responsibilities of BC Hydro, the contractor, Environmental Monitors, and other members of the Project team
- The requirement for Environmental Monitors to immediately advise the contractor's representative who has the authority to stop work, and BC Hydro, of construction activities that are not being conducted in accordance with the applicable EPP
- Environmental reporting and communication structures
- Environmental mapping of sensitive areas
- Procedures for reporting of environmental incidents and emergencies

From time to time, BC Hydro reserves the right to provide the Contractor with updated environmental training materials and minimum content information.

3.2 Pre-work Orientation and Tailboard Meetings

Pre-Work Orientation training shall be provided for each worker prior to beginning construction activities at a site, so that workers are aware of the requirements set out in the EPP applicable to the construction activities to be conducted. Pre-Work Orientation training shall include Bear-Aware training or equivalent.

Field crew Tailboard Meetings shall be held prior to the commencement of construction activities and at regular intervals thereafter. The frequency of subsequent tailboard meetings will be dependent upon the nature of the construction activities and the environmental risks associated with that work. Specific information to be discussed in Tailboard meetings includes, but is not limited to:

- Environmentally Sensitive Areas, potential effects and mitigation
- Construction activities planned
- All applicable mitigation measures, including, for example, Work Avoidance Zones applicable to the planned construction activities, as described in the EPP

- All Pre-Work Orientation Meetings and Tailboards shall be documented by the contractor, and documentation provided to BC Hydro upon request.

4.0 Environmental Specifications

In this section, specifications are provided that must be implemented under EPPs, where applicable to the construction activities. These specifications are largely standard construction practices. In some places, specific commitments made by BC Hydro are specified.

4.1 Air Quality Management

Emissions of criteria air contaminants from Project activities have the potential to affect human health.

BC Hydro will implement an ambient air quality monitoring program in the vicinity of the project. Where measured ambient air quality does not meet the British Columbia Ambient Air Quality Objectives (BC Ministry of Environment, 2015), BC Hydro may require additional mitigation measures such as changes in construction methods or engineered controls to address the issue.

EPPs will address, at a minimum, the following requirements if applicable:

General

- Control of emissions of fine particulate matter (PM_{2.5} and PM₁₀), dust and greenhouse gases
- Pollution prevention, keeping clean areas clean and continuous improvement, as described in A National Commitment to Pollution Prevention (CCME 1993) and Guidance Document on Continuous Improvement and Keeping Clean Areas Clean (CCME 2007)
- Retain vegetative barriers, or install temporary barriers, where practical
- Manage smoke from the burning of clearing debris in accordance with the Smoke Management Plan (Appendix A).

Drilling

- Equip on-site drills with dust suppression systems such as dust collectors or wet drilling systems
- Where wet drilling is prohibited by technical specifications, use another type of dust suppression system

Material Handling

- To reduce dust, when loading materials onto vehicles, stockpiles and conveyors adjust drop heights to less than two meters where feasible
- With materials that may emit dust, cover loads when hauling or use other methods to limit dust generation such as watering the load or reduce speed
- Load trucks so that loads do not spill during movement
- At the Hudson's Hope shoreline protection work area, in the event that project-related construction activity is associated with elevated particulate matter readings above the BC ambient air quality objectives (as described in Appendix B), spray the rock pile handling area with water throughout the day as required when it is visibly releasing dust, as the ambient temperature safely allows

Conveyors

- Enclose transfer points where feasible
- Ventilate transfer points through particulate matter control equipment (i.e., cyclone, baghouse or similar control device) at all times when the conveyors are in operation. For open transfer points, manage dust by water spray, fog nozzles or equivalent
- Minimize the vertical distance between material transfer points to the extent feasible
- When required, clean the ground under conveyors and transfer points to remove accumulations of particulate matter
- Manage dust associated with the off-site portion of the 85th Avenue Industrial lands conveyor belt by enclosing it, or by providing an alternative that is as effective in managing dust associated with operation of the conveyor

Concrete Batch Plant Operations

- Enclose cement and fly-ash storage bins, and associated transfer points
- Operate particulate matter control equipment (i.e., cyclone, bag house or similar control device) during filling of silos
- Regularly inspect and maintain emissions controls in accordance with supplier specification
- Fully enclose the weigh hopper, and ventilate it through particulate matter control equipment (i.e., cyclone, baghouse or similar control device) at all times when it is being filled
- At truck-mix plants, fit the truck loading bays with a telescopic chute, flexible sleeve, or equivalent, long enough to enter the hatches on the truck

Material Extraction and Processing

- Use water sprays as required to suppress dust, except where this would result in not meeting technical specifications of the material being extracted or processed
- Enclose all processing equipment to the fullest extent practical to contain fugitive emissions
- Inspect enclosures regularly and repair as required to control potential emissions
- Equip crushers and screens with particulate matter control equipment (i.e., cyclone, baghouse or similar control device) and water spray bars to knock down fugitive emissions
- Minimize vertical drop distance of materials to transfer points to the extent feasible

Roads and Highways

- Dust shall be controlled on unpaved roads using water or an alternate accepted dust suppressant (calcium chloride or magnesium chloride)
- Dust suppressants shall be applied in accordance with *Environmental Best Practices For Highway Maintenance Activities* (BC MOTI 2010)
- Oil shall not be used as a dust suppressant
- Use of water for dust control will be in accordance with an authorization under the Water Act
- Limit general site traffic to established haul routes
- Define a program for sweeping or cleaning off on-site paved roads based on weather

conditions, traffic volumes and other factors

- Along the haul route from Portage Mountain Quarry to the Hudson's Hope shoreline protection area, in the event that project-related traffic is associated with elevated particulate matter readings above the general road traffic and exceeding the BC ambient air quality objective during the monitoring period (2 hour averaged value rather than 24 hour averaged value, as a conservative approach) as described in Appendix B, apply dust suppressant and/or street sweeping in coordination with the road owner (District of Hudson's Hope or Ministry of Transportation and Infrastructure)

Vehicles and Equipment

- Inspect and maintain vehicles and equipment in accordance with manufacturers' specifications
- Use modern machinery and commercially available low sulphur fuels
- Minimize engine idling to the extent feasible
- Optimize trucking loads to reduce the number of trips between the source and destination

Asphalt Production

- Inspect and maintain the burner and air systems in accordance with manufacturers' specifications in order to ensure that fuel consumption is reduced and carbon monoxide and volatile organic carbon emissions are controlled
- Control the flow of aggregate to ensure that it remains clear of the combustion zone of the burner's flame
- Install thermocouples and other sensors to monitor temperature and pressure change within the burner system
- Regularly calibrate these sensors in accordance with manufacturers' specifications to ensure that they are functioning at their optimum levels

Air Quality Monitoring and Reporting

BC Hydro will monitor air quality in the vicinity of the project, and report the monitoring results, in accordance with the Air Quality Monitoring Program (Appendix B). Results will be provided to contractors.

References

BC Ministry of Environment, 2015. British Columbia Ambient Air Quality Objective. Access via:
https://www2.gov.bc.ca/assets/gov/environment/air-land-water/air/reports-pub/prov_aqo_fact_sheet.pdf

Canadian Council of Ministers of the Environment, 1993. A National Commitment to Pollution Prevention.

Canadian Council of Ministers of the Environment, 2007. Guidance Document on Continuous Improvement (CI) and Keeping-Clean-Areas-Clean (KCAC): Canada-wide Standards for Particulate Matter and Ozone.

BC Ministry of Transportation and Infrastructure, 2018. Environmental Best Practices For Highway Maintenance Activities. Access via:
https://www2.gov.bc.ca/assets/gov/driving-and-transportation/transportation-infrastructure/engineering-standards-and-guidelines/environment/references/envir_best_practices_manual_complete.pdf

4.2 Blasting Management

Dust, noise, and vibration from blasting have the potential to affect the health of humans, wildlife and fish. Potential adverse effects include noise, ground vibration, air blast overpressure, fly-rock, dust, and pollution.

All blasting must be conducted in accordance with Part 21 Blasting Operations of the Guidelines for *Workers Compensation Act* and OHS Regulation.

EPPs will address, at a minimum, the following requirements if applicable:

Timing Windows

- Blasting must be conducted in accordance with *Guidelines for Raptor Conservation* (BC MOE 2013)
- Blasting is prohibited:
 - within 1 km of an active raptor nest from April 1 to July 31 or
 - at Portage Mountain Quarry between September 15 and May 15 all construction and operations work at Portage Mountain Quarry is prohibited within 300 m of identified bat hibernacula
 - at West Pine Quarry between January 1 to March 31
- Blasting levels are limited at the West Pine Quarry to no greater than historical levels from May 15 to June 14

Noise and Vibration

- Comply with applicable environmental guidelines and setbacks for use of explosives near watercourses, including Fisheries and Oceans Canada's *Guidelines for the Use of Explosives In or Near Canadian Fisheries Waters* (Wright and Hopky 1998), or an Authorization

Worker and Public Safety

- Implement mitigation measures to control fly rock
- Secure and limit access to blasting areas to qualified personnel involved in, and necessary for, blasting operations
- Prohibit smoking in and around explosives storage locations and blasting areas
- Maintain fire-fighting equipment in explosive storage facilities and at handling areas
- Design blasts (e.g., reducing maximum instantaneous charge, explosive type, blast pattern, size, etc.) to control blasting energy to only that required. Blast design and supervision shall be undertaken by qualified professionals holding appropriate and valid certification
- Blasting in potentially acid generating rock must be done in accordance with Appendix E Acid Rock Drainage and Metal Leachate Management Plan

Explosives Transportation and Storage

- Comply with all applicable legislation and regulations in connection with the use, storage, and transportation of explosives. Transport explosives components separately and store them in separate and secure designated facilities, located safe distances from other facilities as recommended by qualified professionals

Control of Blast Debris and Dust

- Dust and overpressure shall be controlled by using appropriate blast hole patterns, detonation systems and stemming to prevent venting of blasts
- Safe overpressure limits shall be established by a qualified specialist

References

BC Ministry of Environment, 2013. Guidelines for Raptor Conservation During Urban and Rural Land Development in British Columbia. Access via:

http://www.env.gov.bc.ca/wld/documents/bmp/raptor_conservation_guidelines_2013.pdf

Wright, D.G. and G.E. Hopky, Department of Fisheries and Oceans. 1998. Guidelines for Use of Explosives in or Near Canadian Fisheries Waters. Access via:

<http://www.dfo-mpo.gc.ca/Library/232046.pdf>

4.3 Contaminated Sites Management

Potentially contaminated sites within the Project footprint have been identified and categorized based on the potential for contamination. Thirteen sites were classified as potentially contaminated, and 33 sites were classified as requiring further investigation. In addition, previously unidentified contaminated sites or materials (e.g., soil and groundwater) may be encountered during construction activities.

BC Hydro will:

- Provide the locations of known contaminated or potentially contaminated sites to contractors
- Carry out further investigation on the remaining sites noted above
- Conduct a risk assessment for each site based on the investigation results and the Project activities
- Remediate the site if required by risk assessment

The objective of the general Contaminated Sites Environmental Management Plan is to outline the general procedures that would be followed if suspected contaminated materials are encountered during construction.

EPPs will address, at a minimum, the following requirements if applicable:

Discovery of Potentially Contaminated Soil

- Assess all excavated and imported soils for indicators of potential soil contamination. Indicators of potentially contaminated soils include, but are not limited to:
 - Unusual appearance or odour
 - Staining or sheens
 - Buried debris or trash (e.g., drums, automotive parts, cleaning rags, tanks) or
 - Suspect waste (e.g., batteries and metal parts)
- If potentially contaminated soils are encountered during excavation, segregate these soils from uncontaminated soil and stockpile them separately
- If potentially contaminated soils are encountered during the placement of imported soil, segregate the entire truckload of imported soil and stockpile it separately and immediately notify BC Hydro
- This soil shall be sampled and characterized by a contaminated sites QEP, in accordance with *Technical Guidance on Contaminated Sites 1: Site Characterization and Confirmation Testing* (BCMOE 2009)
- If confirmed to be contaminated, secure contaminated soils and restrict access to authorized personnel and
- Only further handle potentially contaminated soils (e.g., placed or moved) after it has been sampled and confirmed to be non-contaminated by a contaminated sites QEP

Handling, Storage and Movement of Contaminated Soil

- Take the following precautions when stockpiling potentially contaminated soils:

- Cover with plastic sheeting or tarps to prevent erosion
- Install a berm around the stockpile to prevent runoff from leaving the area
- Locate the stockpile at least 15 m from the Ordinary High Water Mark of any water course or wetland
- Handle and store contaminated or potentially contaminated soil under the direction of a contaminated sites QEP
- Track and document the transport of all contaminated material in accordance with the *Contaminated Sites Regulation*

Removal of Wood Poles

Soil around wood poles may contain wood preservatives and be considered contaminated under the provincial Contaminated Sites Regulation.

Where a wood pole IS to be removed completely from the ground:

- All excess soil removed from within one meter of the pole site during wood pole renewal work must be disposed of at a facility authorized to accept this waste

Where a wood pole IS NOT to be removed completely from the ground:

- Poles scheduled for replacement shall be cut about 0.5 m below the surrounding ground level and the hole backfilled with native material. For poles located within Environmentally Sensitive Areas the pole can be cut off at or below existing ground level, leaving the butt in place utilizing non-intrusive techniques. Preferably work within Environmentally Sensitive Areas will be conducted during frozen conditions.

Wood poles may be stored for up to 90 days. Temporary wood poles storage areas must be located at least 10 m from water bodies and Environmentally Sensitive Areas. Storage areas must be less than 46.5 m².

Reference

BC Ministry of Environment, 2009. Technical Guidance on Contaminated Sites 1: Site Characterization and Confirmation Testing. Access via:

<https://www2.gov.bc.ca/assets/gov/environment/air-land-water/site-remediation/docs/technical-guidance/tq01.pdf>

4.4 Erosion Prevention and Sediment Control Management

Construction of the Site C dam may result in the generation of sediment. Other Project construction activities such as relocation of Highway 29, clearing, and transmission line construction may also generate sediment. Sediment has the potential to affect fish, fish habitat and riparian habitat, surface water quality and land use, such as agriculture.

Sediment control system including ditches, retention ponds and settling ponds shall be designed by a Qualified Environmental Professional. Design details, including calculations, shall be submitted to BC Hydro. BC Hydro will make available to contractors the work that it has done regarding construction sediment inputs. Sediment and erosion control structures (for example straw bales, vegetation matting) shall be certified weed free.

EPPs must identify areas of high erosion and sediment potential. EPPs must also follow the requirements for planning, implementing and maintaining water management, erosion and sediment control measures outlined in Appendix I: Water Management, Erosion and Sediment Control Plan.

Erosion prevention and sediment control mitigation measures shall be designed and installed under supervision of a Qualified Professional who is also a Certified Professional in Erosion and Sediment Control (CPESC) as described in BC Hydro's Erosion and Sediment Control Program document, attached as Appendix J of this CEMP. Planning, installation and reporting on such measures as described within the Erosion and Sediment Control Program (ESCP) must be undertaken and signed-off by a QP-CPESC.

While the Plan in Appendix I shall govern overall project water management, erosion and sediment control measures, the following are considered minimum requirements that shall be addressed in EPPs:

Sediment Control

- Effective sediment and erosion control measures shall be installed before starting construction to reduce the potential for introduction of sediment into watercourses
- Applying applicable aspects of Land Development Guidelines for the Protection of Aquatic Habitat (Fisheries and Oceans Canada 1993) and Standards and Best Practices for Instream Works (BC Ministry of Environment 2004), unless otherwise specified in the Environmental Requirements or authorized in a permit or approval
- Design and construction shall follow the Standards and Best Practices for Instream Works (BC Ministry of Environment 2004)
- Control runoff and manage stormwater (for example rainfall or snow melt) and direct it away from construction areas where excavation, spoil placement, and staging activities occur
- Prior to construction of the Jackfish Lake Road, or Project access roads, and of the transmission line, develop, with the assistance of a hydrologist, site-specific measures to reduce changes to the existing hydraulic balance and wetland function during construction, including installation of culverts installed under access roads to maintain hydrological balance and sedimentation barriers
- Isolate in-stream work areas from flowing water to prevent sediment from entering the downstream environment except as permitted by the environmental monitor

- The nature and location of silt fences, berms, swales, ditches, check dams, settling ponds, and other sediment and erosion control facilities, as required
- Contingency supplies of sediment and erosion control materials shall be maintained at each construction site and workers shall be sufficiently trained in their appropriate installation and maintenance
- Sediment and erosion control measures shall be:
 - Inspected regularly at a frequency commensurate with the risk, nature, location, and seasonality of the work
 - Adapted or revised, as appropriate
 - Repaired as necessary in a timely manner, commensurate with the risk, nature, location, and seasonality of the work
 - Maintained until construction is completed and the affected areas are sufficiently stabilized and revegetated so there is minimal risk of erosion or sedimentation at the site as a result of construction activities
 - Sediment and erosion control contingency supplies must be onsite, readily accessible, clearly identifiable, and of sufficient quantity to respond to an event. EPPs must indicate and describe the minimum supply of contingency supplies to be kept onsite, relevant to the work.
- Storage and disposal of construction wastes, overburden, soil, or other substances in such a manner as to reduce the potential for entry into any streams or watercourses including:
 - Stockpiles of materials shall be located at least 15 m from the Ordinary High Water Mark of any watercourse or wetland, unless otherwise reviewed by the Environmental Monitor and deemed to pose a low risk of sediment entry into any waterbody
 - Cover stockpiles of erodible materials such as soil with plastic sheeting or tarps, or establish vegetative cover, to prevent erosion
- Manage equipment production rates if required to reduce the amount of sediment generated
- Use clean rock materials for riprap construction to reduce the amount of sediment that is introduced into the aquatic environment
- When feasible, adjust the timing of construction activities to coincide with periods of high background sediment levels in consideration of the Peace Region aquatic wildlife least-risk windows identified in *Terms and Conditions for Changes In and About a Stream Specified by Ministry of Environmental Habitat Officers, Peace Sub-Region* (BC Ministry of Environment 2010)

Erosion Prevention

- Control site runoff by ditching, grading, sedimentation ponds, check dams or effective alternatives
- Stabilize slopes by maintaining ground cover or using materials such as geotextiles/erosion control cloth
- Leave stumps in place to reduce soil disturbance, erosion and sediment transport in the headpond during reservoir clearing to reduce soil disturbance and potential sedimentation issues. For clarification stumps will need to be removed for infrastructure including access

road and construction pad construction.

- Manage vegetation and soil stripping, taking into consideration slope stability and the proximity to sensitive habitats such as wetlands
- Identify natural drainages that occur within cleared areas and incorporate appropriate sediment and erosion control measures into site planning
- Incorporate perimeter channels, as required, to catch and transport site runoff from new construction sites and equipment staging areas
- Install water bars to direct road surface runoff away from access roads in a safe manner
- Where required, install appropriately sized culverts to reduce road failure through erosion and to manage hydrological balance and wetland function
- Maintain ditches along access roads, as required, to control surface runoff and sediment transport
- Operate machinery on land above the Ordinary High Water Mark in a manner that reduces disturbance to the banks of watercourses
- Remove sediment control measures, such as plastic sheeting and silt fencing, when no longer required, as determined by the Environmental Monitors
- Salvage and stockpile clean surface soils for site restoration
- Establish and maintain vegetative cover on the soils stockpiled for six months or longer to prevent erosion
- Restore disturbed areas to a stable vegetated condition as soon as possible in accordance with 4.12 Soil Management, Site Restoration and Revegetation
- Develop construction schedules such that reservoir clearing in the winter is maximized

Subsurface Mulching

Within the reservoir in areas with a significant component of aspen along with gentle slopes and appropriate soil composition, subsurface mulching may be used to dispose of non-merchantable vegetation. Subsurface mulching is not considered to be grubbing as the latter involves complete removal of a tree stump and root ball while the former only involves grinding tree stumps and roots within the top 20 cm of soil. Subsurface mulching is effective in controlling suckering (quick re-establishment) from subsurface roots or other root-like structures.

Areas to be subsurface mulched will be prescribed by a Qualified Professional and shown in detailed site-maps and these prescriptions will be reviewed with crews during daily tailboard meetings. To avoid re-suspension of mulched woody material during flooding from river diversion and reservoir filling, subsurface mulching will not be permitted within 2 growing seasons or less of the reservoir fill date within the entire reservoir area, or the river diversion date within the headpond flood area. Additionally, only areas that meet the following criteria may be subsurface mulched:

- Average slope gradient is < 20%
- Non- riparian areas (> 15 m away from any waterbody) and not within an active floodplain
- Free of surface drainages and gullies that would not meet the criteria for establishment

- of a riparian area but might otherwise concentrate runoff flow
- Free of animal dens and active bird nests

As soon as they are snow-free, all subsurface mulched areas will be re-seeded by the Contractor with a reclamation seed mix according to the CEMP requirements.

References

BC Ministry of Environment, 2004. Standards and Best Practices for Instream Works. Access via:

<http://www.env.gov.bc.ca/wld/documents/bmp/iswstdsbpsmarch2004.pdf>

BC Ministry of Environment. 2016. Terms and Conditions for Changes In and About a Stream Specified by Ministry of Environmental Habitat Officers, Peace Sub-Region. Access via:

https://www2.gov.bc.ca/assets/gov/environment/air-land-water/water/working-around-water/terms_and_conditions_northeast_region_sept_2016.pdf

Fisheries and Oceans Canada 1993. Land Development Guidelines for the Protection of Aquatic Habitat. Access via:

<http://www.dfo-mpo.gc.ca/Library/165353.pdf>

4.5 Fisheries and Aquatic Habitat Management

Construction activities may affect aquatic habitat and riparian areas. Potential effects include alteration of aquatic habitat and reduction of fish health and survival. Clearing of all project construction sites, including but not limited to the reservoir, transmission corridor, Highway 29, dam site and quarries will be conducted in accordance with Section 3.5 of the Vegetation Clearing and Debris Management Plan.

EPPs will address, at a minimum, the following requirements if applicable:

Protection of Aquatic and Riparian Habitat

- Description of the areas and types of aquatic and riparian habitat with the potential to be adversely affected from construction activities, and mitigation measures and best management practices proposed to reduce, avoid, or offset potential adverse effects
- Unless otherwise authorized in a permit or approval, construction activities will be conducted in accordance with:
 - *A Users' Guide to Working In and Around Water* (B.C. Ministry of Environment, 2009)
- Except at the Dam Site Area (see Figure 2) during clearing, prohibit construction within 15 m of the Ordinary High Water Mark, unless the activity was described in the EIS
- Avoid construction and installation of transmission structures and associated infrastructure (i.e. anchors, guy wires) below the high water mark of any watercourse
- Inform the EM prior to working within 30 m of a watercourse or wetland
- Use existing roads, trails, or cut lines, wherever possible
- Retain a 15 m machine-free riparian buffer from the Ordinary High Water Mark of watercourses and waterbodies during clearing, except where worker safety prohibits manual tree falling and vegetation removal methods, and as addressed in a site specific prescription prepared and endorsed by a QEP. The rationale for the safety exemption must be documented in the prescription
- Locate lay-down and material storage areas at least 15 m from the Ordinary High Water Mark
- Clearly flag or otherwise delineate riparian areas throughout all phases of construction
- Prevent debris and deleterious substances from entering watercourses without effective isolation or a non-toxic chemical barrier to prevent mixing with the surrounding the water column
- Screen the intakes of any pumps in accordance with Fisheries and Oceans Canada's *Freshwater Intake End-of-Pipe Fish Screen Guidelines* (Fisheries and Oceans Canada 1995)
- Conduct visual and/or hydrophone monitoring of underwater sound pressure levels and fish during pile driving, as per BC Marine and Pile Driving Contractors Association's Best Management Practices for Pile Driving and Related Operations (BC Marine and Pile Driving Contractors Association 2003). Implement mitigation measures if the threshold of 30 kPa is exceeded

- During Reservoir Filling and Operations (see Appendix F), maintain in the Peace River, as measured immediately downstream of the Site C dam:
 - a minimum flow of 390 cms
 - a minimum flow of as ordered by an Engineer under the Water Act
- Use readily biodegradable hydraulic fluids in equipment working within or above water

Sediment Controls

Install effective sediment and erosion control measures and conduct construction activities in a manner which reduces the potential for siltation into watercourses in accordance with Section 4.4 of this CEMP.

Work Timing Windows

Unless otherwise specified in the Environmental Requirements, conduct construction activities within watercourses only during the Peace Region aquatic wildlife least-risk windows identified in *Terms and Conditions for Changes In and About a Stream Specified by Ministry of Environmental Habitat Officers, Peace Sub-Region* (BC Ministry of Environment 2010).

The least-risk window does not apply if:

- The stream channel is naturally dry (no flow) or frozen to the bottom at the worksite and the instream activity will not adversely impact fish habitat (e.g., result in the introduction of sediment into fish habitat), or
- Construction of a winter crossing is proposed and such work does not adversely impact the stream channel (including stream banks), fish habitat or fish passage

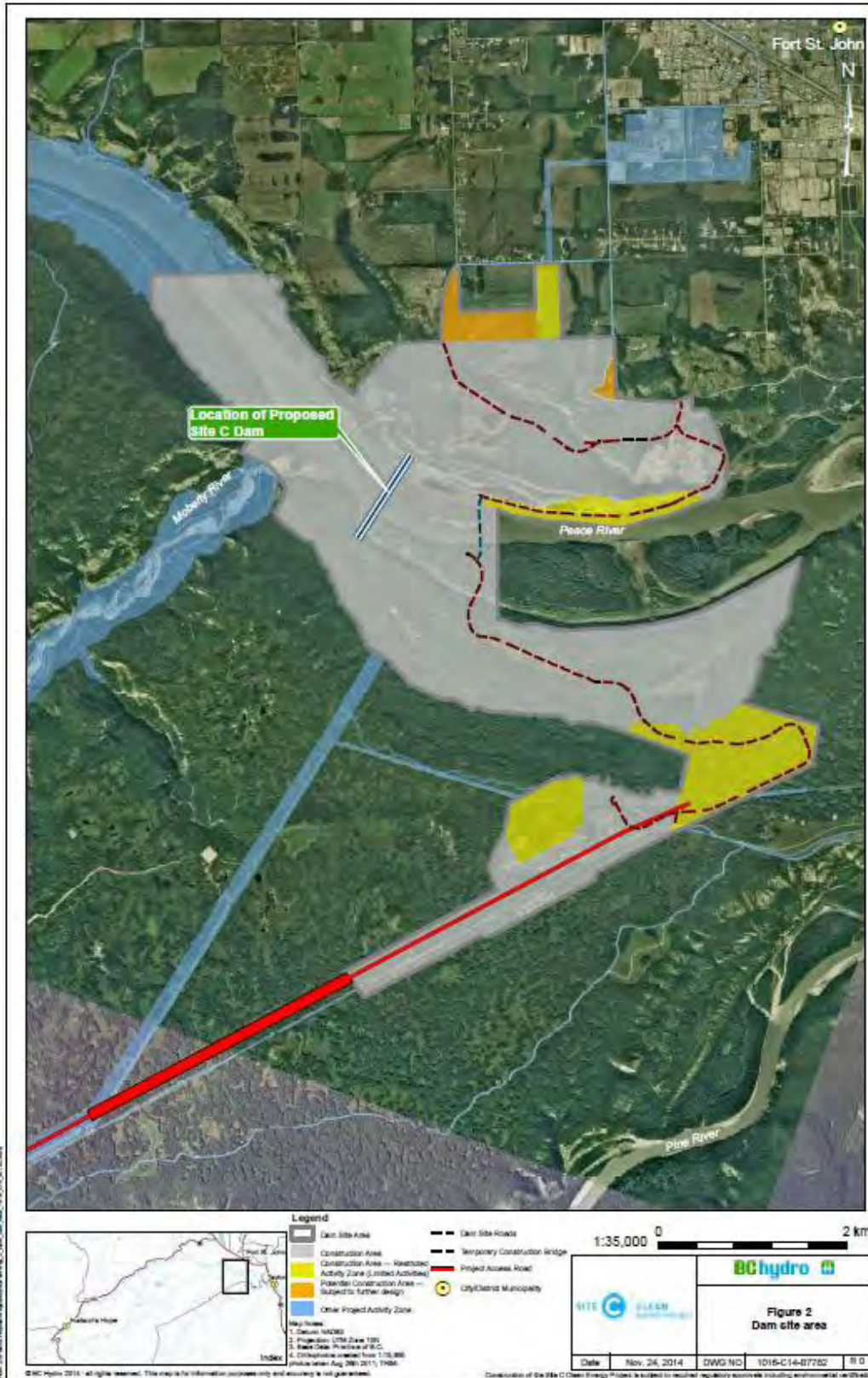

Fish Salvage and Relocation

Unless otherwise specified in the Environmental Requirements, fish salvage shall be conducted prior to the start of construction activities to capture and relocate any fish present within the work area. Fish salvage and relocation plans will be developed that take into account the following considerations:

- Fish salvage activities will be conducted in accordance with fish collection permits issued by MFLNRO and/or DFO
- Where feasible, prior to instream construction work, exclude fish from a section of the watercourse using stop-nets or other suitable measures
- Stop-nets should remain in place for the duration of the instream work, and should be monitored to ensure that they remain free of debris and continue to prevent fish access to the work area
- Fish should be captured by electrofishing, seining, trapping or a combination of these methods
- Alternative fish salvage approaches will be implemented in advance of those works where work area isolation or fish exclusion is not expected to be technically feasible or effective, such as certain instream work components in the mainstem of the Peace River. The intent is to capture those species and life stages that are expected to remain in the work area given the nature of the works being undertaken (i.e., less mobile fish such as species with small adult body size, and juvenile life stages of large fish species). Fish will be captured in advance of the works using methods suited to the habitat where work is planned. Backpack and/or boat electrofishing are potential capture techniques that are suited to these habitats, though other techniques may also be suited. Fish will be relocated well downstream of the work area
- Transport and release salvaged fish into suitable habitat (e.g., habitat in which they are likely to survive), and within the same reach either above or below the construction area, and in a location that would not require re-salvaging. Planning for release locations should also take into account the number of fish expected to be released and the capacity of the habitat. Multiple release locations may be required when large numbers of fish are released
- Fish holding times should be as short as feasible to reduce stress on salvaged fish. Maximum holding times should be specified for each fish species requiring salvaging
- Fish salvage plans in the construction headpond or in the Peace River downstream of Site C should be developed in coordination with the effectiveness monitoring program titled: Fish and Fish Habitat Productivity - Stranding monitoring program

The potential for fluctuating water levels to re-water salvaged areas, the requirement to monitor for this, and the requirement to conduct additional fish salvage as required.

Water Crossings and Instream Works

- As described in the Project's Environmental Impact Statement (EIS Vol 2, Section 11.1.2), existing hydroelectric developments have influenced fluvial geomorphology and sediment transport in the Peace River, resulting in vegetation encroachment onto gravel bars and side channels along the river and an overall reduction in the active channel width. While delineating active channels and the Ordinary High Mark for water crossings and instream works, the QEP will take into account channels that are expected to be active only under the current regulated flow regime.
- Water Crossings and Instreams Works requirements shall be applied to all manner of in-stream work, including but not limited to road crossings, rip rap placement, coffer dam installation and maintenance, in-river excavations, structure placement below top-of-bank, etc.
- Avoid instream construction activities on fish-bearing watercourses during construction of access road crossings where feasible
- Unless otherwise authorized in a permit or approval, the design and construction of water crossings shall follow applicable aspects of:
 - *Standards and Best Practices for Instream Works* (Ministry of Water, Land and Air Protection 2004)
 - *Measures to Avoid Causing Harm to Fish and Fish Habitat* (Fisheries and Oceans Canada 2013)
 - *Fish-stream Crossing Guidebook* (Ministry of Forests, Lands and Natural Resource Operations et al, 2012)
- Per *Standards and Best Practices for Instream Works (2004)*, temporary fords are temporary stream crossings installed to allow transportation or material movement across a channel for a limited period of time. Fords may be used in certain situations to gain access to temporary work areas when bridges or other crossing structures are not required (e.g., bridges for hauling harvested timber)
 - A temporary ford may be used multiple times at a given location for clearing and debris management below the reservoir 5 year beach line
 - The construction of a temporary ford must be undertaken in accordance with Section 39 (v) of the Water Sustainability Regulation
 - All fording will follow guidance from a QEP to reduce potential effects on aquatic habitat. Fords may not be used for the skidding of logs
- QEP prescriptions for fords will require the following details:
 - information on site access (including alternative sites assessed)
 - timing of work
 - machinery to be used
 - provision that instream work is considered high risk (per section 2.4.1) requiring full-time environmental monitoring
 - provision that all equipment will be clean, free of grease and use biodegradable hydraulic oils

- substrate protection, ESC mitigation and restoration requirements
- QEP prescriptions for fords must be provided to BC Hydro and the IEM prior to conducting work. Work crews must receive environmental orientation from the environmental monitor prior to constructing or using fords. Additionally, copies of QEP fords prescriptions will be provided in weekly environmental monitoring reports.
- Design and construct clear-span structures to avoid placement of materials such as abutments and rip rap below the high water mark of any watercourse where feasible
- Isolate instream construction areas in accordance with Appendix 14.2 Work Area Isolation of Standards and Best Practices for Instream Works (BC Ministry of Environment, 2004) and/or as authorized in an applicable permit or approval
- Design and construct approaches so that they are perpendicular to watercourses to reduce disturbance to or loss of riparian vegetation where feasible
- Design and construct bridges so that stormwater runoff from bridge decks, side slopes, and approaches is directed into a retention pond or vegetated area to remove suspended solids, dissipate velocity and prevent sediment and other deleterious substances from entering watercourses, or design and construct drainage on industrial/forestry bridges as per S. 3.10.5 of the Forest Service Bridge Design and Construction Manual (FLNRO 1999) and on public highway bridges as per S. 1.8.2 of the Bridge Standards and Procedures Manual, Volume 1, Supplement to CHBDC S6-14 (MOTI 2016)
- If replacement rock reinforcement/ armoring is required to stabilize eroding inlets and outlets of a culvert, the following measures shall be incorporated:
 - Place appropriately-sized, clean rocks into the eroding areas associated directly with the inlet or outlet
 - Obtain rocks from above the high water mark of any watercourse
 - Avoid the use of rock that is acid-generating
 - Install rock at a similar slope to maintain a uniform stream bank and natural stream alignment
 - Do not place rock where it interferes with fish passage or constricts the channel width

Removal of Naturally Occurring Woody Debris

- Naturally occurring woody debris is described in the Vegetation Clearing and Debris Management Plan
- Mobilization of naturally occurring woody debris during creation and operation of the river diversion head pond and during flood events presents a risk to the river diversion tunnels. Mobilization of naturally occurring woody debris during creation of the reservoir presents a risk to the earthfill dam. The removal of woody debris within the future headpond area, reservoir area, and from the Peace River's larger tributaries (e.g., Moberly River, Cache Creek and Halfway River) in advance of river diversion and reservoir filling will reduce this risk
- The removal of woody debris will occur in accordance with relevant provincial and federal approvals/authorizations
- Loose woody debris shall be targeted for removal. Where it is not practical to remove loose woody debris, it shall be cut into segments no longer than 4m

- Partially buried woody debris shall also be targeted for removal when the debris piece is >4m in length (including root ball), >0.2m in diameter, and less than 50% of the debris piece is buried
- It is not always practical to remove instream and floodplain woody debris during winter conditions. Woody debris can be frozen into the substrate and/or buried under snow and difficult to find. Consequently, QEPs can consider the removal of instream and floodplain woody debris with machinery in unfrozen conditions
- Any instream or floodplain removal of woody debris must be accompanied by a QEP site specific prescription
- Woody debris that is within the wetted channel at the time of removal may be removed with machinery during and outside the fisheries least risk window (July 15 to August 15). If woody debris is removed within the wetted channel outside the fisheries least risk window, the QEP's site specific prescription must include an assessment of fisheries timing risks.
- Woody debris that is not in the wetted channel may be removed with machinery both during and outside the fisheries least risk window
- Skidding woody debris across dry gravel bars or in frozen conditions for the purpose of woody debris removal or movement of debris to piles can be considered in QEP prescriptions. When skidding is complete all skid trails should be inspected for any ESC concerns. Skidding woody debris below the wetted perimeter of a watercourse in unfrozen conditions is not allowed
- Naturally occurring woody debris that cannot be collected during clearing activities may be mobilized by the diversion tunnel head pond and subsequent reservoir inundation. This debris will be intercepted by a number of purpose built structures (booms and piles) to prevent woody debris impacting the diversion tunnel and dam. The build up of woody debris may need to be collected with machinery. Instream work with machinery may be required to remove woody debris in some locations during operation of the diversion tunnels. QEP prescriptions will be required for this work
- QEP prescriptions for instream and flood plain woody debris removal will be prepared for each river reach. QEP prescriptions will require the following details:
 - woody debris removal methodology and machinery to be used
 - timing of work
 - provision that instream work is considered high risk (per section 2.4.1) requiring full-time environmental monitoring
 - provision that all equipment will be clean, free of grease and use biodegradable hydraulic oils
 - marked out skidding routes, ESC mitigation and restoration requirements
- QEP prescriptions for instream and flood plain woody debris removal must be provided to BC Hydro and the IEM prior to conducting work. Work crews must receive environmental orientation from the environmental monitor prior to starting work. Additionally, copies of QEP prescriptions will be provided in weekly environmental monitoring reports.

Water Isolation and Diversion

If it is necessary to complete work within the stream channel, dewatering the site will proceed after effective fish salvage has been completed. The following guidelines shall be implemented during isolation and dewatering:

- The isolation of the work area must not cut off flow to downstream portions of the stream (below the isolation area) at any time during construction. The point of discharge to the stream should be located immediately downstream of the work area and upstream of the fish stop fence
- If surface flow is present, water from upstream should be diverted with a suitable method, such as through a diversion channel, gravity bypass pipe, or by pumping around the site. The point of discharge to the stream should not result in sedimentation, scour, or erosion
- If flow is redirected through a temporary diversion channel, the channel should be lined with an appropriate material (e.g., filter cloth, clean gravel) to prevent erosion of the exposed channel bed
- Following isolation of the work area, sediment laden water that accumulates within the site due to groundwater flow or seepage should be pumped to a suitable sedimentation pond or vegetated area, far enough from the watercourse to prevent direct re-entry into the channel. Excavation of a small sump upstream and downstream of the work area will assist in collecting seepage, which can then be pumped away from the watercourse
- The isolation and diversion structures and equipment shall be monitored and regularly maintained until the works are sufficiently completed and until the Environmental Monitor determines that there is no longer a risk of adverse effects to aquatic resources or water quality as a result of flowing water through the work areas

Decommissioning and Site Restoration

- Unless otherwise authorized in a permit or approval, decommission and remove temporary structures used during construction within the construction season that they are deemed to be no longer required
- Upon completion of construction activities, remove surplus materials and wastes from the work sites, and dispose at appropriate facilities
- Install and maintain appropriate sediment control measures until such time that natural vegetation becomes established
- To the extent possible, restore surface soil adjacent to the stream channel using low impact equipment under dry soil conditions
- Restore riparian management areas disturbed during work to a stable vegetated condition as soon as possible in accordance with 4.12 Soil Management, Site Restoration and Revegetation
- Where possible, re-establish ground cover to allow adequate vegetative growth prior to the onset of rainfall and snowfall events. If this is not possible, alternate erosion measures must be provided
- Upon completion of restoration activities, remove all remaining sediment and erosion control measures, unless necessary to protect areas where vegetation is naturally establishing

- Remove all equipment, supplies and materials associated with the work

Aquatic Invasive Species

Equipment arriving at the Project area could have been in contact with aquatic invasive species. To avoid the introduction aquatic invasive species, EPPs must address, at a minimum, the following:

- List all pieces of equipment used for the Work covered by the EPP that may have come in contact with aquatic invasive species outside of the Project Area
- Demonstrate compliance with the BC Wildlife Act's Controlled Alien Species Regulations
- Measures to avoid the introduction of aquatic invasive species into the Project area, including procedures for equipment inspection, cleaning and treatment of wash water

References

BC Ministry of Forests, Lands and Natural Resource Operations. 1999. Forest Service Bridge Design and Construction Manual. Access via:

http://www2.gov.bc.ca/assets/gov/farming-natural-resources-and-industry/natural-resource-use/resource-roads/bridge-design-construction/bridge_manual.pdf

BC Ministry of Environment, 2004. Standards and Best Practices for Instream Works. Access via:

<http://www.env.gov.bc.ca/wld/documents/bmp/iswstdsbpsmarch2004.pdf>

BC Ministry of Environment, 2009. A Users' Guide to Working in and Around Water: Understanding the Regulation under British Columbia's *Water Act*. Access via:

https://www2.gov.bc.ca/assets/gov/farming-natural-resources-and-industry/natural-resource-use/land-water-use/crown-land/working_around_water.pdf

BC Ministry of Environment. 2016. Terms and Conditions for Changes In and About a Stream Specified by Ministry of Environmental Habitat Officers, Peace Sub-Region. Access via:

https://www2.gov.bc.ca/assets/gov/environment/air-land-water/water/working-around-water/terms_and_conditions_northeast_region_sept_2016.pdf

BC Ministry of Transportation and Infrastructure. 2016. Bridge Standards and Procedures Manual. Volume 1. Supplement to CHBDC S6-14. Access via:

<https://www2.gov.bc.ca/assets/gov/driving-and-transportation/transportation-infrastructure/engineering-standards-and-guidelines/bridge/volume-1/2016/volume-1.pdf>

Fisheries and Oceans Canada, 1995. Freshwater Intake End-of-Pipe Fish Screen Guidelines. Access via:

<http://www.dfo-mpo.gc.ca/library/223669.pdf>

Fisheries and Oceans Canada, 2013. Measures to Avoid Causing Harm to Fish and Fish Habitat. Access via:

<https://www.dfo-mpo.gc.ca/pnw-ppe/measures-mesures-eng.html>

Ministry of Forests, Lands and Natural Resource Operations et al, 2012. Fish-stream Crossing Guidebook: Revised Edition. Access via:

https://www2.gov.bc.ca/assets/gov/farming-natural-resources-and-industry/natural-resource-use/resource-roads/fish-stream_crossing_web.pdf

4.6 Fuel Handling and Storage Management

During construction, fuels will be delivered to and stored on the site for refuelling of service vehicles, equipment and machinery. Mishandling of fuels could affect groundwater and surface water quality, and fish and wildlife habitat. Spilled fuels would create a fire hazard.

EPPs will address, at a minimum, the following requirements if applicable:

- Unless otherwise authorized in a permit or approval, plan, design, and construct fuel storage and handling facilities following applicable aspects of the Standards and Best Practices for Instream Works (BC Ministry of Environment 2004)
- Locate storage, handling and equipment and vehicle maintenance and repair sites on flat, stable ground, at least 30 m from the Ordinary High Water Mark of watercourses and wetlands
- Store single tanks, barrels, and containers greater than 23 litres containing hydrocarbon products within impermeable containment designed to contain not less than 110% of the volume of the container. Containers must be transported upright and secured to prevent shifting and toppling. Impermeable containment is required for stationary fuel storage as well as mobile fuel storage (i.e., fuel trucks) when remaining on site overnight (CCME 2003)
- Store multiple tanks, barrels and containers, each greater than 23 litres, containing hydrocarbon products within impermeable containment designed to contain not less than the sum of: (a) the capacity of the largest storage tank located in the contained space; plus (b) 10% of the greater of: (i) the capacity of the largest tank; or (ii) the aggregate capacity of all other storage tanks located in the contained space
- Containers must be transported upright and secured to prevent shifting and toppling. Impermeable containment is required for stationary fuel storage as well as mobile fuel storage (i.e., fuel trucks) when remaining on site overnight (CCME 2003)
- Containers for hydrocarbon products greater than 23 litres can be stored inside buildings with concrete floors if secondary containment such as plugged floor drains is in-place and the containers are protected with clear signage and barriers
- Store and transport containers that are 23 litres or less in an equipment box of a vehicle that is capable of containing the total quantity of fuel in the container(s) should it leak or spill. If not stored in an equipment box store these containers in impermeable containment as per the above requirements for containers greater than 23 litres
- Store non-hazardous liquids other than water > 15 m away from waterbodies or ditches that connect with waterbodies, or store within impermeable containment designed to contain not less than 110% of the volume of the container
- Operate storage area(s) so that containment systems remain effective during wet weather, and provide protection against theft and vandalism
- Sites shall have a written Spill Contingency Plan with required actions specified and will include the names of those to be contacted
- Plastic containers used to carry petroleum products shall be designed for that purpose
- Verify that containers do not leak and are sealed with a proper fitting cap or lid
- Label containers according to the *Transportation of Dangerous Goods Act Regulations*

- Transport hydrocarbons to and within construction areas, in conformance with the requirements of the *Transportation of Dangerous Goods Act*
- Refuel equipment at least 30 m from the Ordinary High Water Mark of watercourses and wetlands. In locations where this is not practical, describe and implement protective measures to ensure that all spilled fuel is contained and recovered. This includes measures to prevent spills during fueling of boats
- Ensure all sites where fuel handling and storage is happening are equipped with appropriate spill kits
- Inspect vehicles and equipment, including their hydraulic fittings, daily to verify that they are in good condition and free of leaks, and excess oil or grease
- Compressors/generators required at helicopter fly-in sites shall be placed in an impermeable containment area designed and constructed to contain 110% of the volume of any potential fuel spill. Absorbent pads shall be included in the “fly box” tool kits for sites requiring fuel containing equipment
- Store fuels separately from corrosive materials
- Prohibit smoking in the vicinity of fuel storage and dispensing facilities in accordance with the *Occupational Health and Safety Regulations*
- An inspection program for fuel storage (i.e., tanks and transfer systems) and dispensing locations and equipment shall be developed by a qualified professional, and implemented by the contractor. This program shall be submitted to and accepted by BC Hydro prior to construction of fuel storage and dispensing facilities

Reference

BC Ministry of Environment, 2004. Standards and Best Practices for Instream Works. Access via:

<http://www.env.gov.bc.ca/wld/documents/bmp/iswstdsbpsmarch2004.pdf>

Canadian Council for Ministers of the Environment. 2003. Environmental Code of Practice for Aboveground and Underground Storage Tank Systems Containing Petroleum And Allied Petroleum Products. Access via:

http://www.ccme.ca/files/Resources/csm/pn_1326_e.pdf

4.7 Groundwater Protection

Project construction activities that have the potential to affect groundwater quality include, but are not limited to:

- Storage, use, and potential spills of fuels, chemicals and hazardous materials
- Reservoir filling
- Excavation, drilling, and construction around springs and groundwater seeps as well as other activities that can expose groundwater to surface contamination
- Activities that produce waste fluid and water which could infiltrate into the ground (e.g., washing of cement and concrete, camp septic systems, equipment maintenance)

EPPs will address, at a minimum, the following requirements if applicable:

Use of Groundwater

- Non-domestic groundwater diversion or use is regulated under the Water Sustainability Act and the Groundwater Protection Regulation (2016)
 - Identification of licensing requirements for groundwater use

Managing Infrastructure Prior to Inundation

- Inspect all properties with infrastructure within the proposed reservoir footprint for potential sources of groundwater contamination prior to reservoir inundation. Potential sources of contamination include:
 - Building infrastructure
 - Septic tanks and fields
 - Underground storage tanks
 - Debris and waste, within buildings and on the property
- Decommission identified potential sources of contamination associated with properties and infrastructure within the reservoir footprint, prior to reservoir inundation
- Decommission water wells that will potentially be directly inundated by reservoir filling prior to reservoir filling
- Identify, characterize and remediate contaminated sites in accordance with the Contaminated Sites Management Plan

Groundwater Protection Measures

- Drilling will be conducted in accordance with the *Groundwater Protection Regulation*
- Waste liquid shall only be discharged to ground:
 - If it has been sampled and meets applicable standards
 - In accordance with a permit or other provincial authorization, or an applicable regulation or code of practice

4.8 Hazardous Waste Management

Hazardous wastes include, but are not limited to, asbestos, fuels, used fuels, oils, oil filters, greases, bitumen's, lubricants, solvents, cement, paints, solvents, batteries, cleaners, dust suppressants, PCBs, and used spill cleanup materials. Hazardous waste that is spilled could affect surface water quality, air quality, fish habitat, or wildlife habitat.

EPPs will be developed in accordance with *Hazardous Waste Legislation Guide* (BCMOE 2005). EPPs will address, at a minimum, the following requirements if applicable:

- Store, handle and transport hazardous materials to avoid loss and to allow containment and recovery in the event of a spill in accordance with all applicable legislation, including, but not limited to, the BC Fire Code, the National Fire Code of Canada, and the *Transportation of Dangerous Goods Act*
- Designate onsite areas for the transfer and limited temporary storage of hazardous materials and wastes. The area(s) shall be located at least 30 m from the Ordinary High Water Mark of any waterbody, clearly labelled and appropriately controlled. BC Hydro may inspect designated area(s) at any time and may require the prompt removal of any hazardous materials which are not in active use
- Adequately train site personnel in the handling and transportation of hazardous materials
- Dispose of hazardous wastes generated during construction in compliance with the BC *Hazardous Waste Regulation* under the *Environmental Management Act*
- Where construction activities involve the handling, storage, and removal of hazardous wastes, contractors shall maintain the following records:
 - Inventories of types and quantities of wastes generated, stored, or removed
 - Manifests identifying licensed waste haulers and disposal destinations
 - Disposal certification documents

Reference

BC Ministry of Environment, 2005. Hazardous Waste Legislation Guide. Access via:
<http://www2.gov.bc.ca/gov/DownloadAsset?assetId=51C5BF7BBC8140FA93CE2C9AEABBC042>

4.9 Heritage Resources Management

Heritage resources include archaeological, historical, and paleontological sites, objects and features. Construction activities that disturb land could affect heritage resources. In addition to heritage sites, there may be locations of cultural importance (e.g., areas of current traditional use) identified by Aboriginal Groups in the area.

All construction sites require completion of a heritage assessment, in the snow-free season, prior to the start of construction activities. These assessments were completed during the environmental assessment phase prior to construction in most areas. Any areas still requiring a heritage assessment prior to commencement of Work shall be identified in an EPP as indicated below.

BC Hydro will:

- Retain a Heritage Specialist to coordinate BC Hydro's heritage obligations with the Contractors working on the Project
- With the assistance of the heritage specialist, develop a Project-wide construction Heritage Resource Management plan (HRMP) that describes the measures that will be used to mitigate the adverse effects of the Project on heritage resources
- Through its Heritage Specialist obtain permits under the BC *Heritage Conservation Act* that are required for the construction of the Project, which are anticipated to include requirements with respect to the assessment, mitigation and management of heritage resources and requirements to undertake construction activities within protected heritage sites
- Invite Aboriginal Groups to identify to BC Hydro any locations of cultural importance within planned construction areas; lead discussion with Aboriginal Groups, the Heritage Specialist and applicable contractors to identify feasible avoidance or mitigation measures for locations of cultural importance made known to BC Hydro; direct its contractors with respect to avoidance or mitigation measures for such locations

Contractors will be responsible to include heritage requirements as part of an EPP as applicable to the scope of work covered by the EPP. Contractors will be required to cooperate with BC Hydro's Heritage Specialist to develop the heritage requirements of an EPP, and to provide the Heritage Specialist with information in a timely manner about the scheduling of planned work. The Heritage Specialist will support the Contractor in developing the EPP by providing the following as applicable:

- Maps and digital data identifying:
 - Areas within planned construction locations where heritage assessments are not completed and still required
 - Recorded heritage sites
 - Required heritage mitigation and protection measures
- Review of maps of contractors planned construction locations and activities prior to construction commencing to identify heritage management requirements
- Completion of required heritage assessments in accordance with applicable legislation and conditions of permits issued under the BC Heritage Conservation Act, where heritage assessments have not been completed in any construction locations
- Confirmation of the status and timing of planned mitigation for known heritage resources in

accordance with permit conditions issued under the BC *Heritage Conservation Act*

- Confirmation of the status of *Heritage Conservation Act* permits prior to disturbance of known heritage resources
- Implementation of required heritage surface inspections or monitoring after initial ground disturbance associated with stripping, grubbing or excavating within known archaeological sites, in accordance with the conditions of permits issued under the BC *Heritage Conservation Act*
- Qualified Environmental Professionals as required if the contractor discovers a chance find of any previously unrecorded heritage resources and any human remains found during construction activities in accordance with the HRMP, applicable legislation and conditions of permits issued under the BC *Heritage Conservation Act*

EPPs will address, at a minimum, the following heritage requirements if applicable, in accordance with the HRMP:

- Heritage site management requirements, including conditions of permits issued under the BC *Heritage Conservation Act*
- Procedures for the delineation, on maps and on the ground, of known heritage sites within Work Areas to support implementation of site specific heritage site management requirements
- Prohibitions on workers, during the course of their work, from destroying, excavating, altering or collecting any heritage resource without authorization under a BC *Heritage Conservation Act* permit
- Prohibitions on workers from disturbing, destroying or collecting heritage resources for personal purposes
- Implementation of monitoring procedures as specified in the HRMP and as specified in permits issued under the BC *Heritage Conservation Act*
- Chance find procedures with respect to heritage resources, including definition of heritage resources subject to chance find reporting, initial response procedures, and guidelines for determining further action and management of newly found heritage resources

References

BC Ministry of Forests, Lands and Natural Resource Operations, 1998. Archaeological Impact Assessment Guidelines. Access via:

https://www2.gov.bc.ca/assets/gov/farming-natural-resources-and-industry/natural-resource-use/archaeology/forms-publications/archaeological_impact_assessment_guidelines.pdf

BC Ministry of Forests, Lands and Natural Resource Operations, 2011a. British Columbia Archaeological Resource Management Handbook. Access via:

https://www.for.gov.bc.ca/ftp/archaeology/external/!publish/Web/handbook_for_local_government_s.pdf

4.10 Ice Management

BC Hydro operates its existing Peace River facilities under a joint agreement between the provinces of BC and Alberta (Alberta - British Columbia Joint Task Force on Peace River Ice). The Project will be operated in accordance with the agreement. One of the management objectives of the joint agreement is to control flows from BC Hydro's facilities in a way that avoids downstream flooding during ice formation and breakup. Existing ice management practices will continue during the construction phase of the Project.

Construction of the Site C dam will occur in two stages. Stage 1 (channelization) consists of restricting the channel and is expected to last through two or three winters. Stage 2 (diversion) consists of diverting the flow through tunnels in order to isolate the area where the earthfill dam will be constructed across the Peace River and is expected to last through three winters.

BC Hydro will retain a qualified professional to develop and implement a Head Pond Ice Monitoring Plan for the Stage 2 diversion phase of construction. The objectives of the Head Pond Ice Monitoring Plan are to:

- Ensure that ice hazards such as ice jams, and ice accumulation on the construction headpond and downstream of the Project are managed during construction in consideration of worker and public safety
- Establish protocols for managing ice on the construction headpond so that water levels are maintained at a safe level below the top of the temporary cofferdams

Results of this Plan will be reported to BC Hydro and upstream operations will be adjusted accordingly to maintain free flow of water through the diversion tunnels, and sufficient freeboard at the temporary cofferdams.

Monitoring of the downstream ice front will continue as per the operating procedures of the Joint Task Force on Peace River Ice.

4.11 Noise and Vibration Management

The potential to affect noise sensitive receptors (e.g., residences, campgrounds, schools, hospitals, sensitive wildlife) depends on the type of activity and the proximity of that activity to the receptor. The following activities will take place close to residences or campgrounds and therefore the control of noise and vibration is particularly important at the following locations:

- 85th Avenue Industrial Lands: excavating, loading, conveyor operation
- Reservoir clearing
- Construction of Hudson's Hope berm
- Relocation of Highway 29 segments

BC Hydro will notify residents in the vicinity of the project of construction activities in accordance with the Construction Communications Plan (Appendix C) and the Aboriginal Group Communication Plan (Appendix D).

Highway 29 construction work will be conducted in accordance with the MOTI 2016 Standard Specification for Highway Construction (Volume 1, Section 165.16.01).

In the event that a noise complaint is made during construction, BC Hydro will work with the complainant to resolve or come to a mutually agreed upon resolution in accordance with Section 3.1.1 of the *British Columbia Noise Control Best Practices Guidelines* (BC Oil and Gas Commission, 2009). The dam site will be excluded from this arrangement.

EPPs must include a noise management program that describes:

- Any construction activities that create noise that could reasonably be expected to disturb residents in close proximity to the Site and
- The mitigation measures the Contractor will undertake to lessen the impact of the noise created by such construction activities

EPPs will address, at a minimum, the following requirements if applicable:

- Retain or erect acoustic barriers, fencing, and vegetative screens as appropriate
- Maintain equipment in good working order
- Outfit equipment with the appropriate silencers and mufflers, as designed
- Use electric motors, pumps and auxiliary equipment that meet current acoustic industrial and regulatory standards
- Locate stationary equipment away from noise receptors
- Restrict helicopter use to defined flight paths to and from construction sites in order to reduce noise effects on local residents
- Schedule construction activity near homes to reduce the period of disturbance
- Minimize construction traffic and deliveries on local roads during night-time hours (22:00-07:00) to the extent feasible
- Implement drive-through pathways for material drop off or pick-up to reduce use of back-up alarms

- Prohibit free swinging tailgates
- Minimize vehicle idling to the extent feasible
- Minimize the length and duration of helicopter flights to the extent feasible

85th Avenue Industrial Lands

The area surrounding 85th Avenue Industrial Lands includes residences and is sensitive to disturbances. The noise management program for 85th Avenue Industrial Lands shall include:

- Install perimeter fencing around the construction site to restrict access
- Direct site lighting into the site
- Install a 3 m high berm along all boundaries of the site at the start of site development
- Consider the use of secondary berms or portable enclosures or barriers closer to construction activities as a measure to reduce visual or noise impacts
- Retain existing vegetation where feasible to maintain a natural visual and noise buffer, and consider planting vegetation as a measure to reduce visual or noise impacts
- Install portable acoustic barriers near the conveyor belt hopper and an enclosure for the on-site portion of the conveyor belt
- Manage noise associated with the off-site portion of the conveyor belt by enclosing it, or by providing an alternative that is as effective in managing noise associated with operation of the conveyor
- If feasible, use silent back-up alarms during night-time operations
- Design a work and noise management schedule that allows an uninterrupted eight hour sleep schedule for Project workers

Reference

MOTI 2016 Standard Specification for Highway Construction (Volume 1, s 165.16.01)

BC Oil and Gas Commission, 2009. British Columbia Noise Control Best Practices Guidelines.

Access via:

<https://old.bcogc.ca/node/8152/download>

4.12 Soil Management, Site Restoration and Revegetation

Soil management, site restoration, and revegetation activities are intended to restore and revegetate areas disturbed during Project construction to a safe and environmentally acceptable condition that minimizes or prevents soil erosion and the colonization of invasive plants.

Soil management entails activities intended to temporarily store organic soils and coarse woody debris so that these materials can be used to support site restoration objectives. Site restoration activities are designed to recreate the conditions that support the re-establishment of a natural ecosystem state on disturbed sites, or the re-establishment of agricultural landscapes. Revegetation activities support the natural re-establishment of suitable plant cover on disturbed sites.

BC Hydro has developed a Soil Management, Site Restoration and Revegetation Plan (Appendix H) that provides specific objectives to be incorporated into contractor-prepared EPPs. The following sections provide a summary of the related environmental management specifications in Appendix H to be implemented during and after Project construction.

Soil Management

- Identify and appropriately store soil, overburden material and coarse woody debris that could be used to create habitat features during site restoration
- Design, construct and protect soil stockpiles to reduce soil erosion
- Restore soils within agricultural areas, including replacement of topsoil to maintain agricultural productivity in consultation with a Professional Agrologist
- Minimize compaction of undisturbed soils to the extent feasible
- Restore site drainage patterns to natural flow conditions upon completion of soil movement activities, where feasible

Site Restoration

- Provide a schedule of site restoration activities that outlines the progressive reclamation of any temporary disturbance within one year of completion of activities
- Apply certified weed free seed mixtures as specified in Appendix H
- Restore borrow and quarry areas developed for the Project in accordance with Part 10 of the *Health, Safety and Reclamation Code for Mines in British Columbia* (BC Ministry of Energy, Mines and Petroleum Resources, 2008), relevant permit conditions, and the site development plan before the end of the construction season that construction ceases at the site
- Comply with applicable MOTI standards during revegetation of road rights-of-way along Highway 29, except where those requirements conflict with this CEMP, in which case the latter requirement shall prevail
- Contour disturbed slopes to landforms which are safe and stable and compatible with adjacent landforms and proposed future use / restoration objectives
- Create swales and knolls on slopes while maintaining the overall specified slope angles
- Scarify soil surfaces so there are rough and loose, unless the nature of the materials render

them susceptible to erosion

- Return water drainage patterns to pre-disturbance conditions unless specific requirements are required due to Project reliability and safety requirements

Revegetation

- Prepare a revegetation plan that is appropriate to the following four landscape categories

Landscape Category	Defining Features	Planting Recommendations
South aspect slopes	Slopes with grades >10%	Seed mix per Appendix H Woody debris Regionally appropriate tree seedlings
North aspect slopes	Slopes with grades >10%	Seed mix per Appendix H White spruce seedlings Woody debris
Riparian Areas	Within 15 m of the ordinary high water mark	Woody debris Live stakes of balsam poplar, willow and red-osier dogwood For riparian areas to be inundated, Seed mix per Appendix H
Plateau Areas	Slopes with grades <10% that are south aspect, north aspect or riparian	Woody debris Seed mix per Appendix H

- Implement the revegetation plan within one year after completion of construction activities at a site
- Assess the effectiveness of restoration and revegetation works through monitoring and implement corrective actions as necessary to achieve Project objectives

References

BC Ministry of Energy, Mines and Petroleum Resources, 2017. Health, Safety and Reclamation Code for Mines in British Columbia. Access via:

https://www2.gov.bc.ca/assets/gov/farming-natural-resources-and-industry/mineral-exploration-mining/documents/health-and-safety/code-review/health_safety_and_reclamation_code_2017_rev.pdf

Northeast Invasive Plant Committee, 2015

<http://prrd.bc.ca/wp-content/uploads/page/invasive-plants/2015IPCPRRD-Strategic-Plan-and-Profile.pdf>

4.13 Spill Prevention and Response

Spills of chemical or fuels spills, will be reported in accordance with Table 2.

Activities that involve potentially harmful or toxic substances such as oil, fuel, antifreeze, and concrete will follow approved practices and consider *Develop with Care 2014: Environmental Guidelines for Urban and Rural Land Development in British Columbia* (BC MOE 2014) or mitigation measures described herein.

Equipment will be maintained according to manufacturers' specifications to reduce the likelihood of spills.

EPPs will adhere to requirements of the *Spill Reporting Regulation, BC Transportation of Dangerous Goods Act, Environmental Emergency Regulations* and the *Canada Transportation of Dangerous Goods Act*. Each Plan shall also meet current BC Ministry of Environment Guidelines for Industry Emergency Response Plans or equivalent.

EPPs will address, at a minimum, the following requirements if applicable:

Spill Prevention

- Specific instructions on how to reduce the risk of spills
- Storage, handling and labelling of fuels and other hazardous materials. Fuel storage and handling procedures shall be consistent with *A Field Guide to Fuel Handling, Transportation and Storage* (BC MWLAP 2002)
- Implementation of a risk assessment process for recognizing potential hazards and minimizing fuel spills consistent with Section 7 of *A Field Guide to Fuel Handling, Transportation and Storage* (BC MWLAP 2002)
- Equipment refueling and servicing procedures. Machinery shall only be serviced, refueled and washed in designated areas, located at least 30 meters from the Ordinary High Water Mark of any watercourse or wetland
- Incorporation of drip containment measures for fuel dispensing equipment to maximize fuel containment
- If the operation of construction vehicles is necessary within riparian areas, vehicles and equipment shall arrive on site in a clean condition and be maintained free of fluid leaks and grease
- Vehicles and equipment shall be monitored for leaks on a daily basis. Vehicles and equipment shall also be inspected for leaks and excess grease via a detailed multi-point inspection, whereby 20% of the fleet is inspected every week, resulting in the inspection of the entire vehicle and equipment fleet every five weeks
- All inspections and any corresponding maintenance activities shall be recorded on an appropriate tracking table including equipment ID, inspector name, points inspected, etc., and reported out via the weekly environmental monitoring reports
- Provision and deployment of purpose built drip trays under all equipment that is parked for longer than 24hrs

- During periods of rain, drip trays shall be emptied of standing water daily and in a manner which does not cause pollution

Spill Response Equipment

- The minimum required content of vehicle spill kits is:
 1. For all pickup trucks, transport vehicles and equipment with on-board fuel capacity of 500L or less: Goggles, PVC gloves, 10 absorbent pads, 2 absorbent socks (1 m or 3ft long each), 1 container of emergency sealant, 3 heavy duty plastic bags
 2. For all pickup trucks, transport vehicles and equipment with a portable fuel tank with capacity of 500L or less: Goggles, PVC gloves, 10 absorbent pads, 2 absorbent socks (1m or 3ft long each), 1 container of emergency sealant, 3 heavy duty plastic bags
 3. For all pickup trucks, transport vehicles and equipment with on-board fuel capacity of greater than 500L: Goggles, PVC gloves, 20 absorbent pads, 6 absorbent socks (1m or 3ft long each), 1 container of emergency sealant, 5 heavy duty plastic bags
 4. For all pickup trucks, transport vehicles and equipment with a portable fuel tank with capacity of greater than 500L: Goggles, PVC gloves, 20 absorbent pads, 6 absorbent socks (1 m or 3ft long each), 1 container of emergency sealant, 5 heavy duty plastic bags
 5. When working within, above, or within 15 meters of a watercourse or wetland with equipment that may result in a spill of a hazardous substance that suitable absorbent and containment booms be onsite and available for deployment in the event of a spill

The required contents are to be carried in each vehicle inside a container marked “Spill Kit”.

- Spill kit contents for fuel dispensing stations shall be consistent with requirements outlined in Table 9.3 (a) of *A Field Guide to Fuel Handling, Transportation and Storage* (MWLAP 2002). Equipment containing ethylene glycol (antifreeze) or other water soluble chemical shall carry an appropriate number of water soluble chemical absorbent pads in addition to absorbent pads used for petroleum products
- Inspections to compare current contents of spill kits with required contents at Project start-up and whenever a new piece of equipment comes onto site
- Locations and nature of clean-up materials and equipment
- Appropriate training of workers in the use of spill response equipment, including the location, type, and correct deployment of spill response equipment relating to the nature and location of work and potential onsite spills

Spill Response Procedures

- Spill reporting and notification procedures, in accordance with Section 2.5 and as described below
- Containment, recovery and clean-up procedures and training
- Contact information for persons and organizations to be notified in the event of spills or other environmental emergencies (including contact information for the Provincial Emergency Program [PEP] and Environment Canada Emergencies)

If a spill of fuels, oils, lubricants or other harmful substances occurs, the following procedures shall be implemented:

- 1) Make the area safe
- 2) Stop the flow (when possible)
- 3) Secure the area
- 4) Contain the spill
- 5) Notify/Report (EMBC 1-800-663-3456 when necessary – see Table 3)
- 6) Clean-up

Site and activity specific EPPs must include procedures to address spill response related to identified environmental hazards. Generally these procedures would include:

1) MAKE THE AREA SAFE

- Evaluate risk to personal/public, electrical and environmental safety
- Wear appropriate Personal Protective Equipment (PPE)
- Never rush in, always determine the product spilled before taking action
- Warn people in the immediate vicinity and
- Verify that no ignition sources are present if the spill is a flammable material

2) STOP THE FLOW (when possible and safe to do so)

- Act quickly to reduce the risk of environmental impacts
- Close valves, shut off pumps or plug holes/leaks and
- Stop the flow or the spill at its source

3) SECURE THE AREA

- Limit access to the spill area and
- Prevent unauthorized entry onto the site

4) CONTAIN THE SPILL

- Block off and protect drains and culverts
- Prevent spilled material from entering drainage structures (ditches, culverts, drains)
- Use spill containment and sorbent material to contain the spill appropriate to site location and spilled materials

5) NOTIFICATION / REPORTING – as per Table 2 below and Table 1 in Section 4.3

- Determine appropriate Contractor, BC Hydro and regulatory notification obligations and notify appropriate personnel
- When required, the first external call shall be made to **Emergency Management BC (EMBC)**, formerly known as the Provincial Emergency Program (PEP), **at 1-800-663-3456 (24 Hour)**. Spills would then be reported to the appropriate ministries/agencies according to Table 2 below to allow for immediate response (as required) by appropriate staff. For spills to aquatic habitat, collection of water samples shall be undertaken to characterize the nature and extent of the release
- Provide the required information for input into BC Hydro's EIR system

Table 2 Spill Reporting Matrix from Spill Reporting Regulation Schedule of Reportable Levels for Certain Substances

Item	Substance	Quantity	External Reporting Requirements	Internal Reporting Requirements
-	Any Spill	Any amount in aquatic habitat	EMBC, DFO and MFLNRO	Environmental Incident Report (EIR)
-	Oil and Waste Oil	Any amount $\geq 1L$	N/A	EIR
1	Class 1, Explosives as defined in section 2.9 of the Federal Regulations	Any quantity that could pose a danger to public safety or 50 kg	EMBC	EIR
2	Class 2.1, Flammable Gases, other than natural gas, as defined in section 2.14 (a) of the Federal Regulations	≥ 10 kg	EMBC	EIR
3	Class 2.2 Non-Flammable and Non-Toxic Gases as defined in section 2.14 (b) of the Federal Regulations	≥ 10 kg	EMBC	EIR
4	Class 2.3, Toxic Gases as defined in section 2.14 (c) of the Federal Regulations	≥ 5 kg	EMBC	EIR
5	Class 3, Flammable Liquids as defined in section 2.18 of the Federal Regulations	≥ 100 L	EMBC	EIR

6	Class 4, Flammable Solids as defined in section 2.20 of the Federal Regulations	≥25 kg	EMBC	EIR
7	Class 5.1, Oxidizing Substances as defined in section 2.24 (a) of the Federal Regulations	≥50 kg or 50 L	EMBC	EIR
8	Class 5.2, Organic Peroxides as defined in section 2.24 (b) of the Federal Regulations	≥1 kg or 1 L	EMBC	EIR
9	Class 6.1, Toxic Substances as defined in section 2.27 (a) of the Federal Regulations	≥5 kg or 5 L	EMBC	EIR
10	Class 6.2, Infectious Substances as defined in section 2.27 (b) of the Federal Regulations	≥1 kg or 1 L, or less if the waste poses a danger to public safety or the environment	EMBC	EIR
11	Class 7, Radioactive Materials as defined in section 2.37 of the Federal Regulations	Any quantity that could pose a danger to public safety and an emission level greater than the emission level established in section 20 of the "Packaging and Transport of Nuclear Substances Regulations"	EMBC	EIR
12	Class 8, Corrosives as defined in section 2.40 of the Federal Regulations	≥5 kg or 5 L	EMBC	EIR
13	Class 9, Miscellaneous Products, Substances or Organisms as defined in section 2.43 of the Federal Regulations	≥25 kg or 25 L	EMBC	EIR
14	Waste containing dioxin as defined in section 1 of the Hazardous Waste Regulation	≥1 kg or 1 L, or less if the waste poses a danger to public safety or the environment	EMBC	EIR
15	Leachable toxic waste as defined in section 1 of the Hazardous Waste Regulation	≥25 kg or 25 L	EMBC	EIR
16	Waste containing polycyclic aromatic hydrocarbons as defined in section 1 of the hazardous Waste Regulation	≥5 kg or 5 L	EMBC	EIR
17	Waste asbestos as defined in section 1 of the Hazardous Waste Regulation	≥50 kg	EMBC	EIR

18	Waste oil as defined in section 1 of the Hazardous Waste Regulation	≥100 L	EMBC	EIR
19	Waste containing a pest control product as defined in section 1 of the Hazardous Waste Regulation	≥5 kg or 5 L	EMBC	EIR
20	PCB Wastes as defined in section 1 of the Hazardous Waste Regulation	≥25 kg or 25 L	EMBC	EIR
21	Waste containing tetrachloroethylene as defined in section 1 of the Hazardous Waste Regulation	≥50 kg or 50 L	EMBC	EIR
22	Biomedical waste as defined in section 1 of the Hazardous Waste Regulation	≥1 kg or 1 L, or less if the waste poses a danger to public safety or the environment	EMBC	EIR
23	A hazardous waste as defined in section 1 of the Hazardous Waste Regulation and not covered under items 1 – 22	≥25 kg or 25 L	EMBC	EIR
24	A substance, not covered by items 1 to 23, that can cause pollution	≥200 kg or 200 L	EMBC	EIR
25	Natural gas	≥10 kg, if there is a breakage in a pipeline or fitting operated above 100 psi that results in a sudden and uncontrolled release of natural gas	EMBC	EIR

Note: Federal Regulations means the Transportation of Dangerous Goods Regulations made under the *Transportation of Dangerous Goods Act*; Hazardous Waste Regulation" means B.C. Reg. 63/88.

6) CLEAN-UP

- Determine cleanup options and requirements with appropriately qualified professionals
- Mobilize recovery equipment and cleanup crew and conduct cleanup activities
- Dispose of all equipment and/or material used in clean up (e.g., used sorbent, oil containment materials, etc.) in accordance with MFLNRO requirements. Disposal of special wastes (e.g., material with > 3% oil by mass) and contaminated soil must comply with the Environmental Management Act and Regulations
- Replenish spill response kits and equipment

References

BC Ministry of Environment, 2014. Develop with Care 2014: Environmental Guidelines for Urban and Rural Land Development in British Columbia. Access via:

<https://www2.gov.bc.ca/gov/content/environment/natural-resource-stewardship/laws-policies-standards-guidance/best-management-practices/develop-with-care>

BC Ministry of Water, Land and Air Protection, 2002. A Field Guide to Fuel Handling, Transportation and Storage. Access via:

<http://www2.gov.bc.ca/gov/DownloadAsset?assetId=520793AF081F4F5DBD6BAE39BC79BC7E>

4.14 Surface Water Quality Management

Project construction activities in or near streams and water bodies, including clearing, blasting, dam construction, and road construction, have the potential to alter water quality.

EPPs will address, at a minimum, the following requirements if applicable including providing details on surface water management and associated programs within constructed structures capable of retaining water (e.g. Cofferdams, sediment ponds):

Water Quality Monitoring

EPPs will include a water quality monitoring program that will specify water sampling locations, parameters and frequencies. Water quality will be monitored both upstream and downstream of construction areas. Unless otherwise specified in the Environmental Requirements, water quality shall be maintained within the limits shown in Table 3. Water Quality Guidelines.

Contractor Environmental Monitor(s) shall conduct water quality monitoring for turbidity plumes (visual and with a turbidity meter), hydrocarbon sheens from oil and grease (visual), and iron bacteria/ochre (visual) during all construction activities in the vicinity of any watercourse or wetland and monitor pH during concrete works within 30 m of the Ordinary High Water Mark of any watercourse or wetland.

Concrete and Concrete Products

EPPs will identify if concrete products will be used, and what type (e.g., grout, wet curing, etc.). EPPs will also identify if concrete products are going to be used within 30 m of the Ordinary High Water Mark of any watercourse or wetland.

Unless otherwise authorized in a permit or approval, concrete works shall be designed and undertaken in and about a water body must be carried out following applicable aspects of Appendix 14.6 of Standards and Best Practices for Instream Works (BC Ministry of Environment 2004), which states:

- Use pre-cast concrete structures whenever possible
- As concrete leachate is alkaline and can cause aquatic environment conditions that are high toxic to fish and other aquatic life, ensure that all works involving the use of concrete, cement, mortars, and other Portland cement or lime-containing construction materials (concrete) will not deposit, directly or indirectly, sediments, debris, concrete, concrete fines, wash or contact water into or about any watercourse without appropriate isolation, including non-toxic chemical barrier to prevent mixing with the surrounding the water column. . Concrete materials cast in place must remain inside formed structures
- Keep a carbon dioxide (CO₂) tank with regulator, hose and gas diffuser readily available during concrete work. Use it to release carbon dioxide gas into the affected area to neutralize pH levels should a spill occur. Train workers to use the tank
- Provide containment facilities for the wash-down water from concrete delivery trucks, concrete pumping equipment, and other tools and equipment
- Report immediately any spills of sediments, debris, concrete fines, wash or contact water to **1-800-663-3456**. If possible, immediately remove the materials from the water and implement emergency mitigation and clean-up measures

- Use mechanical or chemical means (e.g., Skiment-100SC grout additive) to safely and effectively create a physical or non-toxic chemical barrier that prevents deleterious concrete related works from interacting with any watercourse, stormwater system or water column
- Monitor the pH frequently in the watercourse immediately downstream of the isolated worksite until completion of the works. Emergency measures will be implemented if downstream pH has changed **more than 1.0 pH unit**, measured to an accuracy of +/- 0.2 pH units from the background level, or is recorded to be **below 6.0 or above 9.0 pH units**
- Prevent any water that contacts uncured or partly cured concrete during activities like exposed aggregate wash-off, wet curing, or equipment washing from directly or indirectly entering any watercourse or stormwater system
- Maintain effective isolation or a non-toxic chemical barrier of all cast-in-place concrete and grouting from fish-bearing waters. This isolation or barrier is considered effective if ambient water conditions do not exceed applicable water quality criteria in the period associated with the concrete works
- Isolate and hold any water that contacts uncured or partly cured concrete until the pH is **between 6.5 and 8.0 pH units**, and the turbidity is **less than 25 nephelometric turbidity units (NTU)**, measured to an accuracy of +/- 2 NTU

Water Diversions

Unless otherwise authorized in a permit or approval, temporary water diversions must be designed and constructed following applicable aspects of Appendix 14.2 of Standards and Best Practices for Instream Works (BC Ministry of Environment 2004), which states:

- Isolate your work area from all flowing water, but do not cut off flow to downstream portions of the stream at any time during construction
- Temporarily divert, enclose or pump the water around the worksite. Ensure the point of discharge to the creek is located immediately downstream of the worksite to minimize disturbance to downstream populations and habitats
- For works near or in lakes or larger water bodies, if it is not possible to fully isolate and divert flowing water from your work area due to water depth and volume, isolate your works with a silt curtain to keep silty water from entering clean water

It is expected that it will not be technically feasible or effective to fully isolate or employ silt curtains for many works in the Peace River and large tributaries. In these situations, appropriate Erosion Prevention and Sediment Control will be employed to protect Surface Water Quality.

Acid Rock Drainage and Metal Leachate

Monitoring and reporting requirements as well as measures that will be undertaken to mitigate potential adverse effects resulting from potential sources of acid rock drainage or metal leaching material associated with construction of the Project are described in the Acid Rock Drainage and Metal Leachate Management Plan (Appendix E) and in Technical Specifications applicable to each contract.

The EPP must include the following:

- Water management in and around excavations and RSEMs
- Potentially Acid Generating (PAG) material placement location and schedule
- Definition of Contractor and BC Hydro's responsibilities

- List of qualified personnel undertaking the work
- Sampling locations and frequency
- Performance criteria and sampling methodology and
- Water management in the event of non-compliance

Application of Roadsalt

If roadsalt is used for de-icing roads, it shall be applied in accordance with Table 4 of BC Ministry of Environment's Roadsalt and Winter Maintenance for British Columbia Municipalities Best Management Practices to Protect Water Quality (BC Ministry of Environment. 1998).

Table 3 Water Quality Guidelines

Parameter	Maximum Allowable
Suspended Solids ¹	<ul style="list-style-type: none"> • Change from background of 25 mg/L at any one time for a duration of 24 hours in all waters during clear flows or in clear waters • Change from background of 5 mg/L at any one time for a duration of 30 days in all waters during clear flows or in clear waters • Change from background of 10 mg/L at any time when background is 25 – 100 mg/L during high flows or in turbid waters • Change from background of 10% when background is >100 mg/L at any time during high flows or in turbid waters
Turbidity ¹	<ul style="list-style-type: none"> • Change from background of 8 NTU at any one time for a duration of 24 hours in all waters during clear flows or in clear waters • Change from background of 2 NTU at any one time for a duration of 30 days in all water during clear flows or in clear waters • Change from background of 5 NTU at any time when background is 8 – 50 NTU during high flows or in turbid waters • Change from background of 10% when background is >50 NTU at any time during high flows or in turbid waters
Streambed Substrate Composition ¹	<ul style="list-style-type: none"> • % fines not to exceed: 10% <2 mm, 19% <3 mm, 28% <6.35 mm at salmonid spawning sites • Geometric mean diameter not less than 12 mm (minimum 30-day intragravel dissolved oxygen of 6 mg/L) • Fredle number not less than 5 mm (minimum 30-day intragravel dissolved oxygen of 8 mg/L)
pH ²	6.5 – 9.0
Oil and Grease ³	the surface water should be virtually free of petroleum, animal or vegetable oils

Footnotes:

1. From *Ambient Water Quality Guidelines (Criteria) for Turbidity, Suspended and Benthic Sediments* (BC MOE, 2001)
2. From *Water Quality Guidelines for the Protection of Aquatic Life* (CCME 2012)
3. From *A Compendium of Working Water Quality Guidelines for British Columbia* (BC Ministry of Environment 2006)

Table 4 Roadsalt Application Rates

Application	Description	Application Rate
light application	to prevent black ice when the surface temperature is near freezing with light snow or sleet	60 kilograms per two-lane kilometre (about 1/20 cubic metre)
average application	early in the day when the surface temperature is -4° Celsius and rising under snow, sleet or freezing rain conditions	85 kilograms per two-lane kilometre (about 1/14 cubic metre)
heavy application	early in the day when the surface temperature is -4° Celsius and stable or when the surface temperature is -6° Celsius and rising or late in the day when the surface temperature is -4° Celsius and rising, under conditions of packed snow or ice on the highway surfaces	130 kilograms per two-lane kilometre (about 1/9 cubic metre)

Footnotes:

From (BC Ministry of Environment, 1998)

References

BC Ministry of Environment, 2004. Standards and Best Practices for Instream Works. Access via:

<http://www.env.gov.bc.ca/wld/documents/bmp/iswstdsbpsmarch2004.pdf>

BC Ministry of Environment, 1998. Roadsalt and Winter Maintenance for British Columbia Municipalities Best Management Practices to Protect Water Quality. Access via http://a100.gov.bc.ca/appsdata/acat/documents/r15858/RoadsaltandMaintenance_1233164349911_of308e8c5a1c21e81436e2043ecd8879cca7076bd3c6e889d6245abb2154d899.pdf

4.15 Vegetation and Invasive Plant Management

Construction activities may affect the dispersal of invasive plant species which can out-compete native vegetation, and cause damage to natural environments and agricultural production.

BC Hydro and its Contractors will undertake invasive plant control on work sites, in accordance with BC Hydro's applicable Pest Management Plan (PMP), prior to and during construction, and coordinate control activities, and schedules with Contractors. In addition to the PMP, invasive plants and noxious weeds shall be managed as per the Invasive Weed Mitigation and Adaptive Management Plan in Appendix K.

EPPs must address, at a minimum, the following requirements if applicable:

- Surveys of existing invasive species populations and mapping provided by BC Hydro and by Contractors from prior seasons
- Limit the stripping of vegetation and soils to the areas required for Project activities
- Ensure through equipment and vehicle washing, or other means as appropriate, that weed material is not brought onto Project work sites from non-Project work sites, and that weed material from Project work sites is not transported to non-Project work sites or to other Project work sites that do not presently contain weed populations.
- Manage vehicle movement in a manner that reduces seed dispersal both within and beyond construction sites
- Locate vehicle wash areas at least 30 m from the Ordinary High Water Mark of any water body
- Treat used wash water to prevent seed dispersal and release of contaminants
- Keep machinery on designated routes to reduce damage to surrounding vegetation
- Measures to control invasive plants, manage established invasive species populations and prevent invasive species establishment
- Avoidance/minimization of use of herbicides or pesticides in areas that could impact species at risk, at-risk and sensitive ecological communities and rare plants. Any application will be in accordance with BC Hydro's applicable Pest Management Plan
- In temporary construction areas, plan construction methods that take into account the location of known rare plant occurrences. Where complete avoidance is not feasible, employ measures to reduce adverse effects such as timing construction activities to winter months, placing ramps or mats over occurrences to reduce soil compaction, use of rubber-tired equipment, implementing designated travel routes to and from work sites. See also Section 4.17 Wildlife Management

Reference

BC Hydro, 2012. Pest Management Plan for Management of Vegetation at BC Hydro Facilities. Access via:

<https://www.bchydro.com/content/dam/BCHydro/customer-portal/documents/corporate/safety/pest-management-plan-for-management-of-vegetation-105-0980-12-17.pdf>

4.16 Waste Management

Construction materials and other wastes can cause adverse effects on groundwater and surface water quality, fish and wildlife habitat, and human health and safety.

EPPs will be developed in accordance with *A Best Practices Guide to Solid Waste Reduction* (Canadian Construction Association 2001). EPPs will develop methods for disposal of project-related waste and identify waste management strategies to manage effects on landfills in the region. EPPs will address, at a minimum, the following requirements if applicable:

General Construction Wastes

- Contractor(s) shall make every reasonable effort to control the amount of material disposed of, using regionally available facilities
- Each contractor shall develop and implement a waste management program that integrates waste reduction, reuse and recycling considering the Peace River Regional District's Solid Waste Management Plan
- Contractors shall recycle tires through BC's tire recycling program
- If wastes are generated by contractor(s) in the course of construction, the wastes shall be disposed of in compliance with appropriate environmental waste management procedures and legislation such as the *Environmental Management Act* which are intended to reduce waste and potential for creating health risks and problems for wildlife
- Each contractor shall arrange for disposal of construction-related wastes in a manner acceptable to local governments having jurisdiction, including verification that local landfills have capacity to meet the contractor's disposal requirements
- To avoid otherwise directing this waste to local landfills, the Contractor may dispose of clean (i.e., free of other wastes like plastic, wood, etc.) and cured waste concrete below the reservoir within its permitted lands, provided it is covered with a minimum 1 m thick organic cover layer which does not exceed elevation 455 msl. Any such disposal must be specified in an EPP and the Contractor's monitor must verify cleanliness, burial location, and cover status in a weekly monitoring report.
- Concrete can be buried on BC Hydro owned property (fee simple) under following conditions:
 - Concrete must be well cured and free of any garbage/plastic/wood etc. Only clean and cured concrete can be buried. This must be inspected and verified for all disposals.
 - Rebar within cured concrete can be retained. Rebar protruding outside the rebar must be cut off and removed for recycling.
 - Burial of large blocks of concrete (containing re-bar or not) must only occur where compaction of the fill around the blocks is possible preventing future slumping of the burial area into voids around the blocks.
 - Burial areas must be above groundwater and not have seepage into them.
- Concrete burial sites must be capped to a thickness of 1m of overburden. The capping depth may be altered based on QEP assessment and final restoration requirements for the area.
- Establish regular clean up and disposal programs to prevent the unnecessary accumulation of construction wastes

- Provide sanitary facilities for the use of workers. Sanitary facilities shall be secured so they do not fall over, and shall be located at least 30 m from the Ordinary High Water Mark of any waterbody. Sanitary facilities shall be secured and emptied at a frequency sufficient to prevent potential overflow and spills
- The contractor shall keep records of the types and quantities of waste generated, their handling, transport, disposal date and disposal facility. The contractor shall make the records available to BC Hydro for inspection whenever required
- The contractor shall include 'waste management' within their new worker orientation training which educates the work force on the various waste streams, segregation and recycling requirements and which re-enforces the need to handle food waste in a manner which does not result in these waste becoming animal attractants
- The contractor shall ensure that all waste bins, including recycling bins, include highly visible signage indicating acceptable bin contents and that all waste bins are in place prior to the start of construction works
- All waste bins shall be inspected weekly to ensure they only contain acceptable items and to ensure all signage is appropriate and maintained in good condition

Food Waste

Collect and store all food waste and domestic garbage in metal, purpose-built animal-proof containers that include bear-proof latching and that are emptied regularly. Animal proof containers are those that are considered resistant to entry by bears, birds, rodents and other scavenging wildlife species.

An example is the bearicuda trash can (<http://www.bearicuda.com/enclosures/bear-resistant-containers.php>). The contractor is to provide a schedule for waste removal in their EPP.

Waste Forecasting

Each contractor shall provide to BC Hydro an annual forecast of its expected waste types and quantities by January 31 of each year of construction.

BC Hydro will compile the annual contractor waste forecasts and provide the compilation to the Peace River Regional District by March 31 of each year of construction. BC Hydro will consult with the Peace River Regional District annually to identify waste management options and establish resources and funding arrangements to address any potential shortfall in existing landfill capacity caused by construction of the Project.

References

Canadian Construction Association, 2001. A Best Practices Guide to Solid Waste Reduction. Access via: <http://www.cca-acc.com/pdfs/en/members-only/cca81.pdf>

Peace River Regional District, 2016. Solid Waste Management Plan. Access via: https://prrd.bc.ca/wp-content/uploads/page/plans-and-strategies/SolidWasteManagementPlan_Final_amended_Dec_14_2016.pdf

4.17 Wildlife Management

Construction activities may affect wildlife and wildlife habitat through:

- Disturbance and displacement
- Permanent or temporary habitat loss, alteration or fragmentation
- Direct and indirect mortality and
- Increased wildlife-human contact

EPPs will address, at a minimum, the following requirements if applicable:

Wildlife Protection Measures

- Least-risk timing windows:
 - Where feasible, vegetation clearing will take place during the Peace Region terrestrial wildlife least-risk windows as shown in Table 5
 - If clearing is to take place outside of the least-risk windows or inside the General Nesting Period, the contractor must apply mitigation to minimize the risk of adversely impacting bird nests, eggs and young (i.e., incidental take). In consultation with the Canadian Wildlife Service (CWS) and the BC Ministry of Forests, Lands and Natural Resource Operations and Rural Development (FLNRORD), BC Hydro has developed a protocol for minimizing the risk of incidental take (provided as Appendix N). The protocol outlines approved procedures for determining the presence of active nests and for determining appropriate disturbance setback buffers around active nest sites. Trees would be removed once nests are confirmed unoccupied. Contractors will identify nest surveys completed in weekly monitoring reports, and will provide BC Hydro with information on any new leks located. BC Hydro will provide MOE and FLNRO with information on lek locations identified during nest surveys
- Raptor nests:
 - Bald Eagle Nests
 - Obtain a BC *Wildlife Act* permit prior to removal of any Bald Eagle nest. Nests will be removed in compliance with permit conditions
 - Nests in construction area will be removed prior to construction activities in the direct vicinity of the nest
 - Nests within the diversion headpond area, that could be lost during seasonal headponding, will be removed to reduce the risk of displacement or possible mortality during active nesting
 - Nests that become active for breeding within or adjacent to areas already disturbed by or under active construction, will, during active breeding use, be monitored by a QEP in a timely manner for signs of disturbance due to construction activities, and the QEP will identify and implement mitigation measures to address observed disturbance to breeding activity in accordance with the Guidelines for Raptor Conservation 2013
 - Nests within areas not yet disturbed by Site C Project construction, will, during active breeding use, have an initial buffer applied of 300 m and where active nests are located less than 300 m from existing human disturbance; a QEP will determine an

appropriate buffer. During active breeding use, a QEP will monitor nests in a timely manner for signs of disturbance due to construction activities, and the QEP may identify and implement changes to the initial buffer based on the results of monitoring in accordance with the Guidelines for Raptor Conservation 2013 (MOE 2013)

- Any established buffers around nests active for breeding use will be clearly marked using flagging tape, fencing, spray paint or a combination of these or similar marking methods. Specific construction activities not allowed within buffer areas will be defined by the QEP on a nest by nest basis
- Other raptor nests:
 - Existing raptor nests within construction areas will have a no activity buffer applied during active breeding use, with buffer size 100 m or as determined by a QEP. Buffers will be indicated using flagging tape, fencing, spray paint or a combination of these marking methods
 - Newly occupied or newly constructed raptor nests, within or adjacent (i.e., within the prescribed buffer distance away) to already disturbed or active construction areas, will not have buffers applied
- No buffer will be implemented around raptor nests adjacent (i.e., within the prescribed buffer distance away) to a road being used for site access
- Sharp-tailed grouse leks (communal areas where males perform courtship displays before or during the breeding season):
 - Conduct lek surveys between approximately April 15 and mid-May (end date to be determined by a QEP) in suitable lek habitat prior to initiation of construction activities
 - Determine the need for, scope and duration of lek monitoring during and after construction (any required post construction monitoring will be delivered by BC Hydro) in accordance with the decision tree shown in Figure 3:

Figure 3 - Sharp-tailed Grouse monitoring decision tree

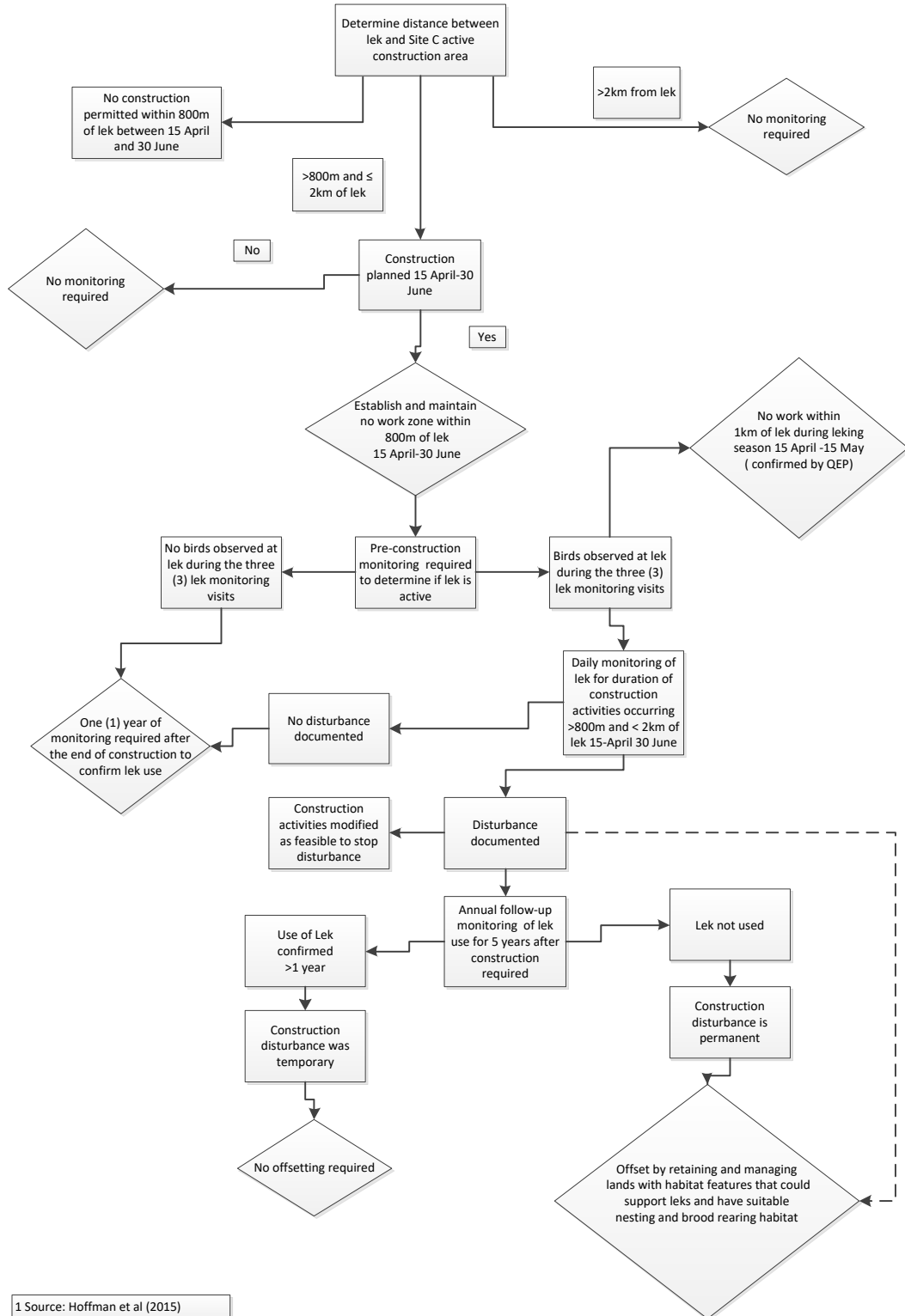



1 Source: Hoffman et al (2015)

- If construction is required adjacent to any leks, implement appropriate monitoring methods as outlined in the *Resource Inventory Standard Committee Standards for Upland Game Birds* (RISC 1997):
 - Leks will be surveyed three times each season in the early morning, surveys will not be conducted during periods with heavy wind, rain or snow
 - Leks will be surveyed by two observers, at least one observer will have experience in conducting Sharp-tailed Grouse lek surveys
 - Surveys will last for 10 minutes or until an accurate count of birds is obtained (Goddard 2010)
 - The total number of birds using the lek will be recorded as will the number of males
 - Data collected during monitoring will be submitted to the provincial database
- If construction occurs within 2 km of the lek between April 15 and June 30 and pre-construction monitoring confirmed the lek was active then:
 - The lek will be monitored daily during the active lekking season, which is defined as April 15 to the date when a QEP determines the lek is no longer being used (normally mid-May), for the duration of the time construction activities occur within 2km of the lek
 - Monitoring will be conducted by a QEP
 - If monitoring determines construction is negatively affecting the use of the lek, the QEP will work with the construction manager to determine how work activities could be adjusted given the constraints of the Project. Additional mitigation measures may include the installation of noise barriers, installation of additional visual buffers, and adjustment of work times
 - If monitoring determined disturbance to the lek occurred due to construction activities, then after construction is complete the lek will be monitored for up to five years or until birds are observed using the lek for >1 breeding season. This monitoring will be managed by BC Hydro
- Amphibian breeding and migration areas:
 - The Contractor's QEP shall conduct amphibian breeding and migration area surveys in advance of ground disturbing activities and alongside active construction roads. Where western toads may exist, the Contractor and its QEP shall follow the Western Toad Management Procedure found in Appendix L. The results of these surveys shall be documented in Contractor's weekly environmental reports
 - Limit vegetation clearing and avoid road construction in identified amphibian breeding and migration areas, where feasible
 - If construction is required adjacent to any identified amphibian breeding and migration areas, implement appropriate barriers and set-back buffers around the sites in accordance with measures for the protection of aquatic and riparian habitat (Section 4.5)
 - Install crossing structures for amphibians and snakes to avoid and reduce injury and mortality to amphibians on roads that cross or are immediately beside wetland or other areas where amphibians or snakes are known to migrate across roads in accordance with Section 8.8 of the Vegetation and Wildlife Mitigation and Monitoring Plan. Notify BC Hydro of such installations within 5 days of installation

- Implement amphibian salvage and relocation procedures as required. Amphibian salvages could be required when avoidance of areas containing metamorphosing tadpoles cannot be avoided, when mass migration events cross access roads, or prior to the destruction of wetlands supporting amphibians
- BC Hydro will seek and maintain a salvage permit for the project. EPP's will contain a detailed salvage plan that is developed in accordance with conditions of the salvage permit. The salvage plan will also include details on contractor post salvage monitoring
- Active den sites
 - At all times of the year Contractor's QEPs shall conduct pre-disturbance den searches in and around areas where ground disturbing or clearing activities are about to occur. This can include areas that were previously disturbed and left unimpacted for a season or more. The results of these searches shall be documented in Contractor's weekly environmental reports and any new confirmed den sites mapped and the Contractor shall provide this updated wildlife features information to BC Hydro
 - A 200 m buffer is required for active den sites. The buffer is to be established immediately upon identification of the active den by any member of the Contractor's or BC Hydro's workforce and shall be retained until the den site is no longer being used by adults or cubs/kits as confirmed by the Contractor's or BC Hydro's QEP. The Contractor's QEP shall establish appropriate buffers for all other species with identified active dens and can modify the 200m buffer dimension by providing a signed site-specific assessment of the den, the species, and the adjacent work, and communicating this assessment every day as applicable in documented tailboard meetings and include the assessment in the Contractor's weekly environmental monitoring report
 - To identify potential den sites, contractors are required to prepare an information sheet that includes representative photos of dens for each wildlife species and describes the types of areas that dens can be expected to be found in and the months of the year each species use dens. This information sheet will be reviewed during orientations and tailboards as required and provided to machine operators and other workers who will be completing ground activities or pre-disturbance surveys
- If a calf or fawn is observed hiding without its mother present, all workers and equipment are to withdraw from the location to a distance determined by the contractors EM. Workers and equipment can return to the site once an EM has determined the calf or fawn has been away from the area for at least 24 hours. Applicable guidance is available in the BC "Leave Newborn Wildlife in the Wild" available at <https://news.gov.bc.ca/stories/leave-newborn-wildlife-in-the-wild-2>

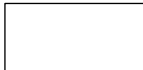
Table 5 Peace Region Terrestrial Wildlife Least-Risk Windows¹

	Jan	Feb	Mar	Apr	May	Jun	Jul	Aug	Sep	Oct	Nov	Dec	Jan
Songbirds				22	1	-	31	24					
Raptors & Owls			1	1	-	-	31	-	30				
Trumpeter Swans				1	-	-	31	31					
Moose & Elk					15		15						
Low Risk 	Restrictions would not normally apply. Where ground conditions permit, plan development activities within these timeframes.												
Caution 	Operators should avoid development activities during these timeframes												
Critical 	Development activities are not appropriate during this timeframe. Aerial activities should adhere to guidelines ² . In the event that working within a critical window is unavoidable, proponent should contact an appropriate qualified professional (e.g. Registered Professional Biologist with BC accreditation) to discuss alternatives, and potential mitigation and monitoring plans.												

Footnotes:

1. From *Peace Region Selected Terrestrial and Aquatic Wildlife Least-Risk Windows* (BC MFLNRO 2011) and Environment and Climate Change Canada’s General nesting periods of migratory birds in Canada (Zone B5; ECCC 2017a)
2. From *Peace Guidelines for Aircraft/Wildlife Interactions* (BC MFLNRO 2008).

General Wildlife Habitat Protection Measures

- Wildfires create a risk of wildlife habitat loss or alteration and the potential for mortality to wildlife. These risks are addressed by following the provisions of the Fire Hazard and Abatement Plan outlined in the Site C Clean Energy Project Construction Safety Management Plan
- Control permanent habitat loss by carefully flagging and restricting clearing to those areas required for construction and the safe and reliable operation of the Project
- Outside the reservoir area, control riparian vegetation clearing including clearing around wetlands, and retain wildlife trees when possible, and safe to do so
- Where live or dead large trees must be removed within the transmission line fall zone, leave tall stumps where feasible and safe to do so
- Focus lighting on work sites and away from surrounding areas to minimize light pollution and disturbance to wildlife. If lighting cannot be directed away from surrounding areas, the Contractor must ensure additional mitigation measures are implemented to reduce light pollution, including light shielding

- Take measures to mitigate against harming migratory birds, nests and eggs as described in *Avoiding harm to migratory birds* (Environment Canada 2017b)

Protection of Important Wildlife Areas

The Environmental Features Map will show Important Wildlife Areas. Contractors will use this data when planning construction activities to identify potential interactions with Important Wildlife Areas and guide avoidance and mitigation planning associated with these areas.

Contractors will provide updated data to BC Hydro. BC Hydro will provide the Environmental Features Map to applicable regulatory agencies prior to the start of construction and as it is updated BC Hydro will notify regulatory agencies, the IEM and affected Contractors.

- Except within the dam site area, on designated access roads and during clearing, construction activities shall be prohibited within 15 m of the Ordinary High Water Mark of streams or wetland, unless the activity was described in the EIS and is accepted by BC Hydro (see Section 4.5, measures for the protection of aquatic and riparian habitat)
- Avoid construction activity within Important Wildlife Areas, including designated set-back buffers, where feasible
- Designation of set-back buffers:
 - If construction activities must be undertaken within a setback buffer, the contractor QEP will develop and implement an appropriate mitigation and monitoring program in consultation with BC Hydro. The contractor QEP must also notify and provide the details of the mitigation and monitoring program to the Ministry of Forests Lands, Natural Resource Operations and Rural Development (FLNRORD) Ecosystems Referral Inbox (ecosystemreferrals@gov.bc.ca) prior to starting the work. Details in the notification to FLNRORD must include the following information, at a minimum:
 - A map and spatial reference coordinates (UTM, lat./long.) identifying the location of the buffered habitat feature, including a shapefile if one is available;
 - Rationale for the request, including description of a precautionary buffer, the mitigation and monitoring plan associated with working within that buffer, and why that plan is likely to be effective at protecting the Important Wildlife Area and individual(s) of the wildlife species in question.
- See also Section 4.15 Vegetation and Invasive Plant Management

Human-Wildlife Conflict Management Plan:

- Food scraps and garbage from construction sites and camps shall be stored in bear-proof containers and removed regularly for proper disposal
- Project workers shall be prohibited from:
 - Feeding wildlife at construction sites
 - Hunting while on construction sites, Project built roads or worker housing sites
 - Cleaning game at construction sites, Project built roads or worker housing sites
- Reduce risk of wildlife-vehicle collisions:
 - Encourage personnel to use as few vehicles as necessary, with multiple people per

vehicle

- Instruct workers that wildlife has the right of way unless it is unsafe (for example if a collision is imminent)
- Adhere to safe speed limits and post them
- Maintain a log of large wildlife sightings and road kill
- Promptly notify appropriate authorities of road kill
- Post warning signs at locations with frequent wildlife crossings
- Provide and maintain wildlife escape routes through snow banks on each side of ploughed roads. Escape routes will be about 500 m apart and one blade width wide and extend to the edge of the surrounding vegetation to enable individual animals to exit the roadway
- Report dangerous human-wildlife incidents to appropriate authorities
- Include wildlife vehicle collisions in tailboard meetings

EPPs will address, at a minimum, the following:

- Provision of no hunting or cleaning game on or in the vicinity of construction sites
- Bear, Cougar and Moose Interaction Management Considerations
- Relative Human Risk from Bears, Cougars and Moose
- General Bear, Cougar and Moose Interaction Management
- Waste Management
 - Solid Waste Management
 - Sewage and Grey Water
 - Petroleum-Based Products
- Bear and Cougar Awareness & Safety Training
- Bear and Cougar Detection
 - Reporting and Recording Bear and Cougar Activity
- Bear and Cougar Interaction Response
- Bear/Cougar-Related Emergency

Wildlife Deterrents

Wildlife deterrent activities and devices may be employed within the Project Activity Zone, and in areas adjacent to the Project Activity Zone where there is a risk of dangerous wildlife or nest occupation by breeding birds.

Deterrent systems may include a combination of animal detection systems, physical barriers, auditory deterrents, and visual deterrents (e.g. airborne devices, kites, balloons, lights, laser deterrents, trained animals (dogs or birds of prey such as hawks or falcons), and models (injured birds or predators). Deterrent type will vary depending on target species, habituation, site conditions and effectiveness of deterrent activities.

Materials that could act as wildlife attractants (e.g. oils, grease, garbage, food scraps) shall be

placed, stored and stockpiled in either animal proof containers or a manner that limits their potential to attract wildlife and as described in Section 4.8 above.

References

BC MOE (BC Ministry of Environment). 2013. Guidelines for Raptor Conservation during Urban and Rural Land Development in British Columbia.

http://www.env.gov.bc.ca/wld/documents/bmp/raptor_conservation_guidelines_2013.pdf.

Accessed 15 June 2017.

BC Ministry of Environment, 2014. Develop with Care 2014: Environmental Guidelines for Urban and Rural Land Development in British Columbia. Access via:

<http://www.env.gov.bc.ca/wld/documents/bmp/devwithcare/>

BC MFLNRO (BC Ministry of Forests, Lands and Natural Resources). 2011. Peace Region Selected Terrestrial and Aquatic Wildlife Least-Risk Windows – April, 2011.

https://www2.gov.bc.ca/assets/gov/environment/plants-animals-and-ecosystems/wildlife-wildlife-habitat/regional-wildlife/northeast-region/best-mgmt-practices/april_2011_least_risk_windows.pdf

BC Ministry of Forests, Lands and Natural Resources, 2008. Peace Region Guidelines for Aircraft Operations/ Wildlife Interactions. Access via:

http://www2.gov.bc.ca/assets/gov/environment/plants-animals-and-ecosystems/wildlife-wildlife-habitat/regional-wildlife/northeast-region/best-mgmt-practices/aircraftbmpjul_1508.pdf.

ECCC (Environment and Climate Change Canada). 2017a. General nesting periods of migratory birds in Canada. Access via:

<https://www.canada.ca/en/environment-climate-change/services/avoiding-harm-migratory-birds/general-nesting-periods.html>

ECCC. 2017b. Avoiding harm to migratory birds. Accessed via:

<https://www.canada.ca/en/environment-climate-change/services/avoiding-harm-migratory-birds.html>

RISC (Resource Inventory Standards Committee). 1997. Standardized Inventory Methods for Components of British Columbia's Biodiversity: Upland Game Birds. Access via:

<https://www2.gov.bc.ca/assets/gov/environment/natural-resource-stewardship/nr-laws-policy/risc/gameml11.pdf>

4.18 Restricted Activity and Work Avoidance Zones

Contractors shall establish restricted activity zones to reduce or avoid potential construction effects in those areas. Only specified construction activities will be conducted within the restricted activity zones.

Environmental, heritage and cultural features and environmentally sensitive areas may also be identified as work avoidance zones. No construction activities will be allowed in work avoidance zones. Examples are:

known tufa seeps, wetlands and rare plant occurrences that are adjacent to construction areas; and sensitive heritage sites as identified in Heritage EPPs.

These sites, and/or a process for identifying and establishing them during construction, must be identified in EPPs. Flagging (type, colour, what it is demarcating and spatial extent of flagging) and other boundary marking measures shall be detailed in EPPs, reviewed in tailboards, and flagging types shall visually described in posters posted in the appropriate construction site-office. The Contractor's QEP shall ensure that restricted activity and work avoidance zone demarcation is appropriate and properly maintained for the duration of construction activity.

5.0 Pre- and Post- Construction Surveys and Monitoring

5.1 Vegetation and Wildlife Surveys

BC Hydro will conduct the following surveys:

- Rare plant surveys (including vascular plants, mosses, and lichens) along the transmission line and temporary access roads
- Invasive plant inventories at work sites
- Bald Eagle nests along the Peace River between Hudson's Hope and the Alberta border, up major tributaries to the Peace River, around select large lakes on the plateau near the transmission line and along the proposed expanded transmission line Right of Way
- Beaver lodges along the Peace River and major tributaries between Hudson's Hope and the Alberta border

BC Hydro will provide the results of these surveys to Contractors, including updates, as appropriate. All Contractors shall include the results of these surveys in their EPPs when considering restricted activity and work avoidance zones (S. 4.18). Contractor's QEPs may need to conduct additional pre-work surveys to confirm and/or augment the BC Hydro surveys to properly inform their work scope and sequencing.

Where available RISC standards will be used to conduct pre-construction surveys. There are currently no formal BC RISC standards for conducting rare plant surveys other than for the collection of voucher specimens. Methodologies for these surveys will be developed using guidelines in the following documents: *Guidelines for Rare Plant Surveys* (Bizecki-Robson, 1998); *Survey Protocols For Survey & Manage Strategy 2 Vascular Plants* (Whiteaker et al., 1998); *ANPC Guidelines for Rare Plant Surveys in Alberta* (Alberta Native Plant Council, 2012); *CNPS Botanical Survey Guidelines* (California Native Plant Society, 2001); *Occupancy Survey Guidelines for Prairie Plant Species at Risk* (Henderson 2009) and *Protocols for Rare Plant Surveys* (Penny and Klinkenberg, 2012).

5.2 Post- Construction Monitoring

BC Hydro and / or contractors will undertake a post-construction site restoration monitoring program at each site, including evaluation of the effectiveness of site reclamation activities by a Qualified Environmental Professional to confirm that the required commitments have been met.

References

Alberta Native Plant Council. 2012. ANPC Guidelines for Rare Vascular Plant Surveys in Alberta - 2012 Update. Prepared for Alberta Native Plant Council, Edmonton, AB. Access via: <http://www.anpc.ab.ca/wp-content/uploads/2015/01/Guidelines-For-Rare-Plant-Surveys-in-AB-2012-Update.pdf>

Bizecki-Robson, D. 1998. Guidelines for Rare Plant Surveys. Prepared for Native Plant Society of Saskatchewan, Saskatoon, SK.

California Native Plant Society. 2001. CNPS Botanical Survey Guidelines. Access via: https://www.cnps.org/cnps/rareplants/pdf/cnps_survey_guidelines.pdf.

Henderson, D.C. 2009. Occupancy Survey Guidelines for Prairie Plant Species at Risk. Prepared for Canadian Wildlife Service, Prairie and Northern Region, Saskatoon, SK. Access via: http://www.npss.sk.ca/docs/2_pdf/Rare_Plant_Occupancy_Survey_Guidelines.pdf

Penny, J.L. and R. Klinkenberg. 2012. Protocols for Rare Vascular Plant Surveys. In: B. Klinkenberg (ed.), 2012. *E-Flora BC: Electronic Atlas of the Flora of British Columbia [eflora.bc.ca]*. Lab for Advanced Spatial Analysis, Department of Geography, University of British Columbia, Vancouver, BC. Access via: <http://www.geog.ubc.ca/biodiversity/eflora/ProtocolsforRarePlantSurveys.html>

Whiteaker, L., J. Henderson, R. Holmes, L. Hoover, R. Leshner, J. Lippert, E. Olson, L. Potash, J. Seevers, M. Stein and N. Wogen. 1998. Survey Protocols for Survey and Manage Strategy 2 Vascular Plants: V 2.0. Prepared For US Bureau of Land Management, Oregon. Access via: <http://www.blm.gov/or/plans/surveyandmanage/files/sp-sp-va-vascularplants-v2-1998-12.pdf>

6.0 Qualified Environmental Professionals

Edits for Revision 10 were prepared by a team of appropriately Qualified Environmental Professionals with review by: Greg Scarborough, RP Bio.

7.0 Appendices

Appendix A Smoke Management Plan

Appendix A

Smoke Management Plan

Site C Clean Energy Project

Revision 5: September 14, 2021

TABLE OF CONTENTS

Revision History	5
Abbreviations and Acronyms	10
Glossary	11
1.0 Introduction	14
1.1 Objectives	14
2.0 Regulatory Context	14
2.1 Provincial Legislation.....	14
2.1.1 <i>Environmental Management Act</i> and Open Burning Smoke Control Regulation	14
2.1.2 <i>Wildfire Act</i> and Wildfire Regulation.....	15
2.2 Site-C – Specific Conditions.....	15
2.2.1 Federal Decision Statement.....	15
2.2.2 Environmental Assessment Certificate Schedule B – Table of Conditions	15
3.0 Scope	15
4.0 General Requirements	16
4.1 Identify Sensitivity Zones	17
4.2 Material to be Burned.....	17
4.3 Timing of Burning	18
4.4 Setback Distances.....	18
4.5 Burn Criteria.....	21
4.5.1 Division 1 – Open Burning by High, Medium, and Low Smoke Sensitivity Zones.....	22
4.5.2 Division 5 – Open Burning Using Air Curtain Incinerators.....	24
4.5.3 Venting Forecasts.....	25
4.5.3.1 Venting Forecast Sources.....	26
4.5.4 Burn Duration / Burning Period.....	27
4.5.5 Change in Burning Conditions.....	28
4.6 Burn Registration.....	28
4.6.1 Category 3 Piles	28

4.6.2	Category 2 Piles	28
4.7	Records and Reporting	29
5.0	Smoke Reduction – Best Management Practices	29
5.1	Seasonal Burn Planning	29
5.1.1	Burn Season.....	29
5.1.2	Burning Prioritization.....	29
5.1.3	Sensitive Time Periods	30
5.2	Debris Pile Construction and Seasoning.....	30
5.2.1	Pile Size, Shape and Components	30
5.3	Pre-Burn Protocols	32
5.3.1	Collate Burn Plan Information.....	32
5.3.2	Venting Forecasts.....	32
5.3.2.1	Limitations of Venting Index and Forecasts	32
5.3.3	Communication with Forecasters.....	34
5.3.4	Training	34
5.3.5	Environmental Considerations.....	34
5.4	Light-Up Procedures.....	35
5.4.1	Pre-burn Checklist	35
5.4.2	Ignition Plan.....	38
5.4.3	Daily Ignition Period	38
5.4.4	Pile Ignition.....	38
6.0	Monitoring and Tracking.....	39
6.1	Monitoring	39
6.2	Tracking.....	40
6.2.1	Burn Tracking	40
6.2.2	Record Keeping and Submission.....	44
6.2.2.1	Weekly Submission	44
6.2.2.2	Upon Request.....	44
6.3	Air Quality Monitoring, Advisories and Burn Bans	44
7.0	Notification and Wildfire Reporting	45

7.1	Notification	45
7.1.1	Public	45
7.1.2	First Nations	45
7.1.3	Other Stakeholders	45
7.2	Wildfire Reporting	47
7.3	Key Contacts.....	47
8.0	Qualified Professionals.....	49
9.0	Works Consulted.....	50

LIST OF TABLES

Table 1. Setback Distances	18
Table 2. Sensitive Receptors Requiring a Setback Equivalent to Hospitals, Schools, and Community Care Facilities, as Identified in Appendix B Air Quality Monitoring Program of the Construction Environmental Management Plan (CEMP).	19
Table 3. Burn Criteria for Open Burning Completed Under Division 1 by High, Medium, and Low Smoke Sensitivity Zones.	22
Table 4. Burn Criteria for Open Burning in Modified Setbacks.....	24
Table 5. Burn Criteria for Open Burning Under Division 5, Using Air Curtain Incinerators .	25
Table 6. Venting Indices	26
Table 7. Example Open Burning Pre-Burn Checklist for Category 2 and Category 3 Fires. The Pre-Burn Checklist may be Modified or Adapted to Better Suit Aerial Ignitions.....	36
Table 8. Recommended Daily Ignition Period.....	38
Table 9. Burn Tracking Form, including an example entry. Ignitions on different parcels, different geographic location or Smoke Sensitivity Zone, or difference in Burn Category (Category 2 / Category 3) would necessitate additional entries or additional forms. An asterisk (*) indicates reporting requirements from the OBSCR.....	42
Table 10. An example of an acceptable burn period / smoke release monitoring form.	43
Table 11. Geographical Units and Key Stakeholders for Notification. Contacts for key stakeholders are found in Section 7.3.....	45
Table 12. Key contacts for notification, party responsible for notification, and primary method of notification.....	47

Revision History

Version	Date	Comments
Rev 2	March 2018	<ul style="list-style-type: none"> • Table detailing revision history to align with requirements in the CEMP S. 2.4. • Rationale for edits to align with requirements in the CEMP S. 2.4. • Add references to relevant legislation, as footnotes. • Reformat and change order of content. Section changes are noted in revision history table. • Replace 'Primary' and 'Secondary Smoke Sensitivity Zones' with 'Category A' and 'Category B Areas', respectively, to align plan with wording and definitions used in currently enacted legislation. • Reduce scope of document; remove vegetation clearing activities, which are guided by the Vegetation Clearing and Debris Management Plan (VCDMP). Remove references to VCDMP and all vegetation clearing activities which are guided by the VCDMP. • Move content in Appendices to body of document. • Add definitions for BCWS, CEMP, EIS, MFLNRORD (update to reflect current Ministry name), and VI. Delete definitions for acronyms VCDMP, PM 2.5, PSSZ, SSSZ and reformatting and alphabetization (Abbreviations and Acronyms). • Clarify regulatory framework applicable to burning activities. Remove guidance provided by OBSCR policy intentions. Addition of Wildfire Act and Wildfire Regulation and Site-C conditions (Federal Decision Statement and Schedule B - Table of Conditions). Add potential for 'substitute requirements' if new legislation is enacted during the project (S. 2.1 / S. 2.1.1, 2.1.2, 2.2) • Separate regulatory framework from plan scope to simplify plan organization (S. 2.0 / S. 2.0, 3.0) • Remove vegetation clearing activities from plan scope (S. 2.2 / S. 3.0). • Remove Vegetation Activities by Project Area; activities guided by VCDMP (S.3.0 / N/A). • Clarify and distinguish in the plan those components that are: required by legislation or are required as BMPs to meet open burning / smoke condition objectives. Rename section to better reflect the contents. Removed reference to VCDMP and references to potential, future regulations. Changes align plan to currently enacted legislation, remove irrelevant references, clarify regulatory requirements, and provide contractors and monitors operational best practices to meet or exceed smoke management objectives (S. 4.0 / S 4.0). • Clarification of annual burn program planning requirements. Content split into subsections. Addition of prioritization of areas under good venting conditions (S. 4.2 / S. 5.1.1, 5.1.2). • Change 'to be determined' to 'may be determined' to more accurately reflect the ground truthing activities and communications which have occurred since Ver. 1 (S. 4.3 / S. 5.1.3). • Add 'schools in session, identified sensitive receptors, and continuing health care centres' as land use requiring minimum 1,000 m setback. Add list of identified sensitive receptors. Changes are to remain consistent with the categories outlined in currently enacted legislation (OBSCR), Appendix B of the CEMP, Appendix L of the EIS, and Condition 57. Add allowance for application to relax minimum

Version	Date	Comments
		<p>setbacks to allow alignment with currently enacted legislation (OBSCR) (S. 4.4 / S.4.4).</p> <ul style="list-style-type: none"> • Smoke release periods re-defined to match definitions in currently enacted legislation (OBSCR) (S. 5.0 / S.4.5). • Addition of annual allowable burning periods and smoke free periods to the burn criteria for Category A Areas to align plan to currently enacted legislation (OBSCR) (S. 5.0 / S. 4.5). • Reformat and move daily ignition period (S. 5.0 / S. 5.4.1). • Remove redundant definition daily ignition period (S. 5.2 / N/A). • Add methods to amend daily burn plan, in the case of changed venting conditions: allow use of forced air mechanism or extinguishing burning (S. 6.1 / S. 5.3.2). • Add provincial ambient air quality objectives. Update BCH-installed particulate monitoring station (number and locations) (S. 6.2 / 6.2). • Delete Post Season Custom Venting Forecast Analysis to align with currently enacted legislation (OBSCR) (S. 6.3 / N/A). • Clarify methods, responsibility, and requirement of obtaining BRN for Category 2 and 3 burns to align with currently enacted legislation (Wildfire Regulation) and with requirements in the CEMP S. 2.4. (S. 7.1, Appendix A / S. 4.6). • Clarify roles and responsibilities regarding notification including: stakeholders based on geographic location, timing of notification(s), notification responsibility, and required documentation (S. 7.2, Appendix D / S. 7.0, 7.1). • Clarify tracking responsibility, add tracking requirements and amend submission timing and format. Required tracking: daily burn logs, documentation of compliance with smoke release period, nest/ den survey results, setback relaxation approvals, and debris reduction monitoring. Add example entry of burn tracking form (S. 7.3, Appendix C / S. 6.1.1). • Delete annual burn reporting to align with currently enacted legislation (S. 7.4 / N/A). • Update revision information (QP and date) (S. 8.0 / S. 8.0). • Update works consulted (S. 9.0 / S. 9.0). • Expand and clarify piling requirements (locations prohibited, definitions, fuel break) (Appendix A / S. 5.2.1). • Identify contractor responsibility for burn plan. Provide direction for burning in the event that ventilation forecast is not representative of local conditions. Provide additional considerations prior to practical applications for venting forecasts (forecaster confidence, prioritization of areas, wind direction, location of values potentially impacted) (Appendix A / S. 5.3.1, 5.3.2). • Add pre-burn considerations, requirement and example template of pre-burn checklist (Appendix A / S. 5.4). • Reduce allowable surface area of debris emitting smoke at the end of the smoke release period from 10% to 5% for Category B areas to align with currently enacted legislation (OBSCR) (Appendix A / S. 6.0). • Expand upon connection between venting forecasts, ventilation index, ventilation category, mixing height and wind speed (Appendix B, S. 5.1 / S. 4.5.1). • Replace Table 6 notification list with detailed contact list, by geographic area

Version	Date	Comments
		<p>(Appendix D / S. 7.3).</p> <ul style="list-style-type: none"> • Add objectives for SMP to align with requirements in the CEMP S. 2.4 (N/A / S. 1.1). • Define 'Category Areas' and addition of Category Area mapping to align with requirements in the CEMP S. 2.4. (N/A / S. 4.1) • Add prohibited materials, acceptable timing of burning, and specific conditions which limit burning to align plan to currently enacted legislation (OBSCR) (N/A / 4.2, 4.3). • Add definition of Category pile sizes and conditions to align plan to currently enacted legislation (Wildfire Regulation) (N/A / S. 4.2). • Define sources of venting forecasts; identify acceptable use of sources (N/A / S. 4.5.1.1). • Recognize smoke free periods and allowable annual smoke release periods as legislated requirements to align with currently enacted legislation (OBSCR) (N/A / S. 4.5.3, 4.5.4). • Add 'stop-burn' conditions to align with currently enacted legislation (OBSCR) (N/A / S. 4.5.5). • Recognize risk of hold-over fires, add conditions for burning outside of normal burning windows (N/A / S. 5.1, 6.0). • Add local validation of venting forecast through use of test piles (N/A / 5.3.2). • Clarify training requirements, contractor responsibility regarding training, competence, and record-keeping to align with requirements in the CEMP S. 2.4 (N/A / 5.3.4). • Add Environmental Considerations section to require den and active nest surveys prior to ignition (N/A, 5.3.5). • Add acceptable methods to monitor and measure smoke release period to ensure compliance with currently enacted legislation; require contractor to develop measurable reporting and documentation of smoke release period compliance. Add infrared scheduling information (N/A / S. 6.1). • Define and identify wildfire reporting requirements to align with currently enacted legislation (Wildfire Act and Wildfire Regulation) (N/A / S. 7.2). <p>These revisions are not material within the meaning of Section 2.6 because:</p> <ul style="list-style-type: none"> • The revisions will not result in a reduction of any monitoring or reporting requirements; • The revisions will not result in the deletion or reduction of an environmental specification; • The revisions will not otherwise make an adverse effect more likely, nor become more adverse and be significant.
Rev 3	Nov. 2019	<ul style="list-style-type: none"> • The entire document was reviewed and updated to reflect regulatory changes, specifically the September 2019 Open Burning Smoke Control Regulation. Edits and updates include changes in: practices to ensure compliance with new or amended regulatory requirements; technical definitions and how new definitions apply to practices or regulatory interpretations, and terminology (minor changes to wording generally not impacting practices). Updates to Rev 3 include updating all citations to the current Open Burning Smoke Control Regulation (from BC Reg.

Version	Date	Comments
		<p>145/93 to BC Reg. 405/19).</p> <ul style="list-style-type: none"> • Add Glossary to define words and phrases from the relevant legislation, as well as to define words and phrases recurring throughout the document. • Update to the footnote legal citation style. • Update S. 2.1.1 to describe newly enacted OBSCR. • Update S. 3.0 to clarify scope of the document. • Update S. 4.0 to reflect OBSCR (terminology) and to reflect the changes in section headings of the updated SMP (to ensure consistency throughout document). • Update S. 4.1 to introduce smoke sensitivity zones which replace category areas. Delete maps outlining outdated category areas. Provide direction to provincial mapping for smoke sensitivity zone identification. • Move definitions in S. 4.2 to glossary. Update criteria and definition of allowable and prohibited material to be burned (origin of material, banned materials, requirement to minimize material for open burning) as per new OBSCR. • Update S. 4.3 to introduce 'burn criteria' as required elements for burning, as per new OBSCR. Clarify and outline situations which supersede burn criteria and under which burning may not occur, as per OBSCR. • Update S. 4.4 with regulation setbacks and option to burn with modified setbacks, as per OBSCR. Change terminology (continuing care to community care) to remain consistent with legislation. • Update S. 4.5 to reflect OBSCR: 'ignition criteria' is changed to 'burn criteria', addition of burn divisions potentially applicable to the Project. • S. 4.5.1 defines specific burn criteria for burn division 1: by smoke sensitivity zone and modified setbacks. • S. 4.5.2 defines burn criteria for burn division 5: burning using air curtain incinerators. • S. 4.5.3 relates venting forecasts to burn criteria and relevant tables. • S. 4.5.3.1 removes option to test burn as acceptable venting forecast. Removes reference to 'parcel' as the main unit for determining compliance with OBSCR. Update ventilation forecasting website. Align terminology 'custom ventilation forecaster' with OBSCR. • S. 4.5.4 align burn period, burn duration, and burn 'end' definitions with OBSCR. Identify pile as the unit for regulatory compliance (burn criteria, smoke sensitivity zone, burn duration are all measured by pile). • S. 4.5.4 allows option to move vegetative debris from the point of origin to provide some operational flexibility. • Update 4.5.5 with wording consistent with OBSCR. • Add S. 4.7 to outline new reporting requirements, as per OBSCR. • S. 5.0 clarify that best management practices also include regulatory requirements. • S. 5.1.1 add 'burn criteria' to encompass all the criteria required for ignition under OBSCR. • S. 5.1.2 replace 'category areas' with 'smoke sensitivity zones'. Add requirement to minimize soil content mixed in with vegetative debris. Add seasoning requirements based upon smoke sensitivity zone. Clarify that minimum setbacks differ for open

Version	Date	Comments
		<p>burning piles versus use of an air curtain incinerator. All changes were made to comply with OBSCR.</p> <ul style="list-style-type: none"> • S. 5.1.2 include option for BCH to authorize hand-piling (as per CEMP) in RRZs, if necessary due to topographic limitations; change is to offer flexibility for piling in highly constrained areas. • S. 5.3.1 replace 'category areas' with 'smoke sensitivity zones'. • S. 5.3.2 remove reference to test burn as an approved method for obtaining venting forecast. • S. 5.3.2.1 replace 'category areas' with 'smoke sensitivity zones'. Remove option to apply to the MOE for a longer smoke release period; this is no longer an allowable practice under OBSCR. • S. 5.3.5 allows for use of drones during den surveys. Allowance for QEP to provide environmental rationale, when deemed appropriate by the QEP, in place of completing another den survey after the duration of validity has expired. • S. 5.4 add specific reference to aerial ignition and requirement of an ignition plan. • S. 5.4.1 remove bulleted examples of safety, regulatory and operational variables for the pre-burn checklist to reduce redundancy from other sections. Clarify requirement to comply with <i>Wildfire Act</i> and Regulation as part of pre-burn checklist. • S. 5.4.1, Table 7 (pre-burn checklist) update to reflect regulatory changes and terminology. Wording clarification for pile locations specific to RRZs. • S. 5.4.2 include requirement for, and minimum components of, an ignition plan. • S. 5.4.3, Table 8 update to comply with OBSCR (daily ignition period by smoke sensitivity zone). • S. 5.4.4 require aerial ignitions to comply with specific helicopter company safe work procedures and best practices. • S. 6.1 update monitoring requirements to comply with OBSCR definitions of 'end' in terms of open burning. Include acceptable actions in the event that piles do not achieve desired levels of debris consumption or comply with burn 'end' requirements, as per OBSCR. Add allowance to use thermal scans for hazard abatement monitoring. • S. 6.2 summarize / clarify list of records created during proper implementation of the smoke management plan. Include requirement for ignition plan. • S. 6.2.1 updates to burn tracking procedure. Updates to data collection requirements and update Table 9 (burn tracking form) to comply and be consistent with OBSCR. Add Table 10 as an example system to document compliance with OBSCR, in terms of burn period and smoke release monitoring. • S. 6.2.2, S. 6.2.2.1 and S. 6.2.2.2 clarify record-keeping responsibility and expected frequency of record submission to BCH. • S. 7.0 clarify that 'reporting' is in reference to the reporting of a wildfire or escaped open burn. • S. 7.3 update key contacts. • S. 8.0 update with current and applicable OBSCR. • S. 9.0 update works consulted.

Version	Date	Comments
Rev 4	Sept. 2020	<ul style="list-style-type: none"> The entire document was reviewed for potential amendments required due to regulatory changes, specifically the Wildfire Regulation, BC Reg 38/2005, amended June 26, 2020 by B.C. Reg. 157/2020. No edits or updates were required as a result of this review. MOE changed from Ministry of Environment to Ministry of Environment and Climate Change Earle Plain title and contact details updated
Rev 5	Sept 14, 2021	<ul style="list-style-type: none"> Updated Table 3 to amend the 'period for igniting piles of unlit vegetative debris' and 'period for adding unlit vegetative material to ignited piles' within the MSSZ to be consistent with Open Burning Smoke Control Regulation (B.C. Reg 152/2019). Updated Table 12, key contacts for notification, specifically contacts for the following: Ministry of Environment and Climate Change Strategy, RCMP Hudson Hope Detachment, RCMP Fort St John Detachment, City of Fort St John, Fort St John Fire Department, District of Taylor and Fire Department, District of Hudson's Hope, Hudson's Hope Fire Department, Chetwynd Fire Department, BC Wildfire Service, Northern Health, BC Hydro Public Relations and Communications.

Abbreviations and Acronyms

BCWS.....	British Columbia Wildfire Service
BMP	Best Management Practices
BRN.....	Burn Registration Number
CEMP	Construction Environmental Management Plan
CVF.....	Custom Venting Forecast
EAC.....	Environmental Assessment Certificate
EAO.....	BC Environmental Assessment Office
EIS.....	Environmental Impact Statement
HSSZ.....	High Smoke Sensitivity Zone
LSSZ	Low Smoke Sensitivity Zone
MFLNRORD....	Ministry of Forests, Lands, and Natural Resource Operations and Rural Development

MOE.....Ministry of Environment and Climate Change

MSSZ.....Medium Smoke Sensitivity Zone

OBSCR.....Open Burning Smoke Control Regulation

SMPSmoke Management Plan

VI.....Venting Index / Ventilation Index

Glossary¹

Burnt surface area: the area that is underneath or surrounding the remains of a fire and covered by charred or smoldering vegetative debris.

Category 2 open fire²: an open fire, other than a campfire, that:

- (a) burns material in one pile not exceeding 2 m in height and 3 m in width,
- (b) burns material concurrently in 2 piles each not exceeding 2 m in height and 3 m in width, or
- (c) burns stubble or grass over an area that does not exceed 0.2 ha.

Category 3 open fire³: an open fire that burns:

- (a) material concurrently in 3 or more piles each not exceeding 2 m in height and 3 m in width,
- (b) material in one or more piles each exceeding 2 m in height or 3 m in width,
- (c) one or more windrows, or
- (d) stubble or grass over an area exceeding 0.2 ha.

Community Care Facility⁴: premises or part of a premises (a) in which a person provides care to 3 or more persons who are not related by blood or marriage to the person and includes any other premises or part of a premises that, in the opinion of the medical health officer, is used in conjunction with the community care facility for the purpose of providing care, or (b) designated by the Lieutenant Governor in Council to be a community care facility.

Custom ventilation forecast: a forecast of the atmosphere's ability in a geographic area to disperse smoke and which is (a) obtained from a custom ventilation forecaster, and (b) submitted by email to the ministry, using the email address made known by the ministry for the purposes of receiving custom ventilation forecasts, before starting open burning.⁵

¹ Unless otherwise noted, all definitions in the glossary are from BC Reg 405/19 Part 1 – Definitions.

² BC Reg 38/2005, s. 1(1)

³ BC Reg 38/2005, s. 1(1)

⁴ *Community Care and Assisted Living Act* S.B.C. 2002, c. 75, parts 1 and 3 and BC Reg 405/19, Part 1.

⁵ BC Reg 405/19, s. 16

Custom ventilation forecaster: a person who (a) is a meteorologist employed by Environment Canada and classified as a Meteorologist 3 or above, (b) is a Weather Forecaster, a Fire Weather Forecaster, an Air Quality Meteorologist or an Air Quality Science Specialist employed by or under contract with the government, or (c) has similar knowledge and experience as described in paragraph (a) or (b) and is approved in writing by a director to conduct custom ventilation forecasts for the purposes of this regulation.

Dry basis moisture content: with respect to a given amount of vegetative debris, means the weight of moisture contained in the vegetative debris divided by the weight of the vegetative debris if the vegetative debris was dry, with both weights measured in the same weight units, multiplied by 100 and expressed as a percentage.

End (with regards to open burning): (a) if the open burning is being done using an air curtain incinerator, the point in time when the fire in the air curtain incinerator is emitting smoke from no more than 10% of the base of the air curtain incinerator, and (b) respecting all other open burning, the point in time when each pile of vegetative debris has ceased flaming and is emitting smoke from no more than 10% of its burnt surface area;

Fire suppression system⁶: a system for suppressing fire by delivering: (a) water, (b) a suppressant, (c) a surfactant, or (d) any combination of the substances (a) to (c) and may include a water delivery system.

High smoke sensitivity zone: (a) land in the province that is outlined and shaded in pink and labelled 'High Smoke Sensitivity Zone' in the legend, on a map listed in Schedule 3 except all areas of that land that are designated under section 7 as being a medium smoke sensitivity zone or a low smoke sensitivity zone, and;
(b) all areas of land that are designated under section 7 as being a high smoke sensitivity zone".

Low smoke sensitivity zone: land in the province that is not a high smoke sensitivity zone or a medium smoke sensitivity zone.

Medium smoke sensitivity zone: (a) land in the province that is outlined and shaded in yellow, and labelled "Medium Smoke Sensitivity Zone" in the legend, on a map listed in Schedule 3 except all areas of that land that are designated under section 7 as being a high smoke sensitivity zone or low smoke sensitivity zone, and
(b) all areas of land that are designated under section 7 as being a medium smoke sensitivity zone".

Opacity⁷: the degree to which smoke obscures the view of an object in the background, expressed numerically from 0% (transparent) to 100% (opaque).⁸

Seasonal residence⁹: a fixed residence that, while not being occupied on a full-time basis, is occupied on a regular basis. A regular basis does not imply a scheduled occupancy but implies use of six weeks per year or more. The residence must not be mobile and should have some sort of foundation or features of permanence (e.g., electrical power, domestic water supply,

⁶ BC Reg 38/2005, s. 1(1)

⁷ BC Reg 405/19, s. 28(1)

⁸ As determined in accordance with the United States Code of Federal Regulations, Title 40, Part 60, Chapter 1, Appendix A-4, Method 9, as amended from time to time.

⁹ Alberta Energy Regulator 2007

septic system) associated with it. Summer cottages or mobile homes are examples of seasonally occupied dwellings, while a holiday trailer simply pulled onto a site is not.

Seasoned vegetative debris: vegetative debris that (a) has been dried to the extent that the dry basis moisture content is 30% or less, (b) has been put in piles for a period of at least 4 months, or (c) has originated from standing dead timber.

Water delivery system¹⁰: a system that can (a) deliver a sufficient volume of water to effectively fight a fire of a reasonably foreseeable size, taking all factors into consideration, including the conditions of the area where the water delivery system may need to be used, and (b) deliver water to any place at the site of an industrial activity, on the burn area or the high risk activity, or reasonably adjacent to the burn area or the site of a high risk activity.

¹⁰ BC Reg 38/2005, s. 1(1).

1.0 Introduction

As part of the planning associated with the Site C Clean Energy Project (the Project), and the environmental assessment process, a Smoke Management Plan (SMP) was developed and submitted with the Environmental Impact Statement (EIS) (BC Hydro 2013) and currently exists as Appendix A of the Construction Environmental Management Plan (CEMP).¹¹ The SMP describes how project-related burning will be conducted compliant with the most current British Columbia Ministry of Environment Open Burning Smoke Control Regulation (OBSCR) and other relevant regulatory requirements, outlines best management practices to reduce smoke emissions and mitigate air quality impacts from burning, and remains in accordance with the Site C Clean Energy Project Construction Environmental Management Plan (CEMP), section 5.1 Air Quality Management, which states:

- Manage smoke from the burning of clearing debris in accordance with the Smoke Management Plan (Appendix A).

1.1 Objectives

The objectives of the SMP are as follows:

- Outline regulatory requirements of open burning activities;
- Detail Best Management Practices to avoid, mitigate, or minimize the emissions of smoke and particulates from open burning; and,
- Ensure consistency and compliance with all relevant provincial and federal conditions mandated as part of the environmental assessment process.

2.0 Regulatory Context

2.1 Provincial Legislation

2.1.1 *Environmental Management Act* and Open Burning Smoke Control Regulation

Under the authority of the Environmental Management Act 12, the BC Ministry of Environment (MOE) has the mandate to regulate smoke emissions from open burning activities through the application of the Open Burning Smoke Control Regulation 13 (OBSCR). The OBSCR is divided into the Part 1 – Interpretation and Application, Part 2 – General Requirements for Open Burning, Part 3 – Specific Requirements for Open Burning, Part 4 – Substituted Requirements, Part 5 – Air Protection Measures, and Part 6 - Miscellaneous. The Open Burning Smoke Control Regulation 405/19 is under effect as of September 15, 2019 and has replaced the repealed Open Burning Smoke Control Regulation 145/93. Revision 3 (November 2019) of the SMP is to reflect the regulatory changes reflected in the recently enacted OBSCR. This plan may need to be reviewed and updated to reflect any future changes in legislation.

¹¹ B.C. Hydro. 2016. Construction Environmental Management Plan, Site C Clean Energy Project Revision 4.

¹² *Environmental Management Act* S.B.C. 2003, c. 53

¹³ BC Reg 405/19

2.1.2 *Wildfire Act* and Wildfire Regulation

The *Wildfire Act*¹⁴ and Wildfire Regulation¹⁵ define the legal responsibilities and obligations regarding fire use, wildfire prevention, wildfire control, and rehabilitation. These pieces of legislation are the responsibility of the Ministry of Forests, Lands, and Natural Resource Operations and Rural Development (MFLNRORD) and, more specifically, the BC Wildfire Service (BCWS). The Wildfire Regulation lays out the responsibilities of a person or entity igniting a fire including, but not limited to: ensuring no fire escapes, providing sufficient fire suppression systems and personnel, and defining fire control requirements in the case of an escape. Additionally, it is the Wildfire Regulation which requires notification to the MFLNRORD (Burn Registration Number), depending on the category of burn defined by the size and number of piles ignited¹⁶, as well as the information required to receive the registration number¹⁷. Although the Wildfire Regulation does not address smoke control or air quality, it is directly relevant to open burning.

2.2 Site-C – Specific Conditions

2.2.1 Federal Decision Statement

The Federal Decision Statement, issued November 25, 2014, by the Minister of Environment Canada and under Section 54 of the *Canadian Environmental Assessment Act, 2012* (CEAA), establishes conditions with which BC Hydro must comply. Relevant to the Smoke Management Plan is Section 12 – Health of Aboriginal Peoples – Air Quality. Specifically, Section 12 requires measures to avoid or minimize exceedances of federal and provincial air quality objectives and to minimize or manage the potential effects of smoke.

2.2.2 Environmental Assessment Certificate Schedule B – Table of Conditions

The Environmental Assessment Certificate was issued with 77 Conditions under which the project may proceed. The following conditions are directly applicable to the SMP:

- Condition 57, which outlines provincial conditions regarding ambient air quality, specifically the requirements regarding an Air Quality Management Plan and a Smoke Management Plan. This condition mandates that project-related smoke is controlled by following the OBSCR. Additionally, the plan is to include measures to manage emissions and procedures to provide MOE with: 1) data collected during monitoring; and, 2) the SMP and any amendments for review.
- Condition 70, which stipulates that Project effects through construction and operations must be managed by implementing measures detailed in mitigation and monitoring plans, such as this SMP and the Contractor's Environmental Protection Plan.

3.0 Scope

The smoke management plan outlines the practices for burning clean woody / vegetative debris (open burning) to manage the effects of smoke emissions from burning, to reduce the risk of an

¹⁴ *Wildfire Act* S.B.C. 2004, c. 31

¹⁵ BC Reg 38/2005

¹⁶ BC Reg 38/2005, s. 22 (1) (c)

¹⁷ BC Reg 38/2005, s. 24 (1)

escape, and to meet all regulatory requirements relevant to open burning. The scope of the smoke management plan is limited to open burning practices implemented as part of the Site C Clean Energy Project.

4.0 General Requirements

All burning activities will be compliant with, or exceed the requirements of, the BC OBSCR¹⁸. The following measures have been developed in accordance with these existing regulations and other relevant regulatory requirements:

1. general requirements;
2. identification of smoke sensitivity zone(s);
3. material to be burned;
4. timing of burning;
5. minimum set-back distances;
6. ignition criteria and burn duration;
7. burn registration; and,
8. Records and reporting.

Best Management Practices (BMPs) are intended to provide operational direction to, as much as practicable, promote fast and efficient burns which minimize the amount of smoke generated and confine smoke emissions as much as possible to periods with favourable venting thereby minimizing potential impacts of smoke from burning activities, and minimize the chance of fire escape. BMPs are outlined in Sections 5.0, 6.0, and 7.0 include direction in the following areas:

1. seasonal burn planning;
2. debris pile construction and seasoning;
3. pre-burn protocols;
4. light-up procedures;
5. monitoring and tracking; and,
6. Notification and wildfire reporting.

¹⁸ BC Reg. 405/19

4.1 Identify Sensitivity Zones

The OBSCR and allowable burning practices are based upon three spatial Categories: high, medium and low smoke sensitivity zones. The zones are based upon distance from populations: the 'high' zone is immediately surrounding communities, while the 'low' zone is farthest from population centers.

To identify the relevant sensitivity zone, use the provincial interactive mapping application found here:

<https://governmentofbc.maps.arcgis.com/apps/webappviewer/index.html?id=6d288bc667b24528a5c1e3b4c0373d07>.

The smoke sensitivity zone and relevant operational requirements (burn criteria) for open burning is designated per pile and by pile location.¹⁹

In addition to the aforementioned regulated spatial zones, through ground-truthing exercises with Aboriginal groups, or during the notification period, locations of high Aboriginal use may be identified, and shall be treated as high smoke sensitivity zones during planned burning activities (i.e. utilize burn criteria for high smoke sensitivity zones).

4.2 Material to be Burned

This smoke management plan applies solely to open burning of vegetative (clean woody) waste that meets Category 2 and Category 3 pile sizes and has been piled within a 5 km radius of where the vegetative debris originated.²⁰

In areas where operations vary between the two Category of burns (Category 2 and Category 3), differences will be noted, else, practices and operations will be the same.

Prior to open burning, BCH and the contractor must ensure that every reasonable alternative for reducing, reusing, or recycling the vegetative debris has been used in order to minimize the amount of debris burned.²¹ Vegetative debris usage is detailed in the Vegetation Clearing and Debris Management Plan.

Open burning that does not meet the definition provided above is outside the scope of this SMP and may require additional permits from the MOE.

Regulations prohibit the burning of the following material in any quantity: animal carcasses; asphalt or asphalt products; batteries; biomedical waste; carpets; construction waste other than lumber that has not been treated with wood preservatives or other chemicals and is not coated with paint, varnish, oil or other finishing material; demolition waste; electrical wire; fibreglass and other fibre-reinforced polymers; fuel and lubricant containers; furniture and appliances; hazardous waste; manure; paint and varnish; plastics; polystyrene foam; railway ties; rubber; tar paper; tires; treated or painted wood products; and used oil.²²

¹⁹ Personal communication (email), October 10, 2019 from OBSCR@gov.bc.ca.

²⁰ BC Reg. 405/19, s. 9

²¹ BC Reg. 405/19, s. 10

²² BC Reg. 405/19, s. 12 and BC Reg. 320/2004, schedule 1, s. 2

4.3 Timing of Burning

Open burning may occur when in accordance with all burn criteria, including acceptable venting. See Section 4.3 for burn criteria and Section 4.5.3 for details on acceptable venting forecasts.

Prior to ignition, it must be confirmed that there are no other burning restrictions in place. This includes burning restrictions from relevant local government²³, the MOE²⁴, and MFLNRORD (bcwildfire.ca), all of which supersede venting indices or venting forecasts, including custom venting forecasts (CVF).²⁵ The OBSCR grants the MOE the authority to prohibit burning in an area during periods of poor air quality, when it is likely that air particulate matter will reach unacceptable levels within 24 hours²⁶, or when pollution is occurring or likely to occur from open burning.²⁷ In these circumstances, the MOE may require fires extinguished, prohibit additional debris added to the fire, or prohibit ignition.

Burning may not be initiated if the local air flow or atmospheric mixing is likely to cause smoke to have a negative impact on a nearby population or workcamp or create a navigational hazard at nearby airports or on nearby highways by significantly reducing visibility.²⁸ Both of these conditions override the existence of an acceptable venting forecast and/ or compliance with all other burn criteria.

4.4 Setback Distances

The minimum fire setback distances that will be maintained for burning operations carried out under the Site C SMP are described in Table 1.

Areas may be identified during ground-truthing exercises with Aboriginal groups, or through the notification process, that meet the definition of “seasonal residence”. Identified seasonal residences will have appropriate fire setback distances applied (Table 1).

Table 1. Setback Distances

Category	Setback Distance (m) ²⁹	Modified Setback Distance (m) ³⁰
Neighbouring buildings: residences (including seasonal residences in use), businesses	500	100
Nearest property line of: hospitals, schools, community care facilities, and identified sensitive receptors ³¹	1,000	500

²³ BC Reg. 405/19, s. 6(a)

²⁴ BC Reg. 405/19, s. 30(1)(a)(b)

²⁵ BC Reg. 38/2005, s. 22(1)(a)

²⁶ Specifically, when the amount of particulate matter in the air in an area has reached, or will reach within 24 hours, a level that is likely to result in the air quality not meeting the ambient air quality objectives set out in Schedule 2 of OBSCR.

²⁷ BC Reg. 405/19, s. 30(1)(a)(b)

²⁸ BC Reg. 405/19, s. 14(a)(b)

²⁹ BC Reg. 405/19, s. 13(1) and the Site C Clean Energy Project Construction Environmental Management Plan Appendix B - Air Quality Monitoring Program

³⁰ BC Reg. 405/19, s. 13(2)

³¹ Identified sensitive receptors as outlined in the CEMP Appendix B – Air Quality Monitoring Program.

Modified setback distances are allowed under OBSCR, when open burning complies with specific burning conditions. The burn criteria for modified setbacks is detailed in Table 4 of Section 4.5.1. Open burning utilizing air curtain incinerators have unique setbacks to pile burning; setbacks for air curtain incinerators are found in Table 5 of Section 4.5.2.

Sensitive receptors for the area have been identified in Environmental Impact Statement (EIS) Volume 2 Appendix L. Those sensitive receptors which require a minimum setback of 1,000 m are enumerated in Table 2. Regardless of sensitive receptors listed in Table 2, any and all hospitals, community care facilities, or schools require setbacks based on relevant burn criteria, as outlined in Table 1, Table 4, or Table 5.³²

Table 2. Sensitive Receptors Requiring a Setback Equivalent to Hospitals, Schools, and Community Care Facilities, as Identified in Appendix B Air Quality Monitoring Program of the Construction Environmental Management Plan (CEMP).

Schools	Health Care Facilities	Senior Care Facilities	Childcare Facilities
Aboriginal Education Center	Fort St. John Health Unit	Heritage Manor III	Chunky Monkey Daycare
Alwin Holland	Fort St. John Hospital	Peace Lutheran Apt. #1	Oscare Daycare/Oscare Tots
Baldonnel Elementary	Fort St. John Medical Clinic	Peace Lutheran Apt. #2	The Zoo Daycare
Bert Ambrose Elementary	Fort St. John Pharmacy and Wellness Centre	The Sunset Home	Little Kritters Daycare
Bert Bowes Middle School	The Taylor Medical Clinic	North Peace Care Centre	ABC & 123 Family Daycare
Board Office	ABC Medical Clinic	Abbeyfield Houses of Fort St. John	Baby Bear Daycare
Charlie Lake Elementary School	North Peace Medical Clinic	New Senior Housing	Rascals
Christian Life School		Peace Villa	Building Blocks Daycare
CM Finch Elementary			Kidz Club
Dr. Kearney Middle School			Northern Lights College Daycare
Duncan Cran Elementary			Little Bear Family Daycare

³² BC Reg. 405/19, s. 13 (1) and (2)

Schools	Health Care Facilities	Senior Care Facilities	Childcare Facilities
École Central Elementary			Little Peanuts Family Daycare
Facilities and Transportation			Little Pigs Family Daycare
Key Learning Centre			Nanny Norma's Daycare
North Peace Secondary			Pitter Patter Day Care
Energetic Learning Campus			Puddle Jumpers
Northern BC Distance Education			Seeds to Sow
Open Learning			The Playground Family Daycare
Robert Ogilvie Elementary			The Wiggles and Giggles Daycare
Student Support Services			TJ's Playhouse
Taylor Elementary			Tot's and Tikes Family Daycare
Technology Services			The Stepping Stones Centre
Upper Halfway Elementary			Aboriginal Head Start
Wonowon Elementary			Child Development Centre
			Keeginaw Pre-School
			Totem Pre-School
			Rise and Shine Clubhouse
			Barney and Friends Family Daycare
			Hudson's Hope Playschool

Best Management Practices shall be employed so that smoke does not negatively impact a nearby population centre or workcamp or pose a hazard at airports or on provincial highways by significantly reducing visibility.³³

4.5 Burn Criteria

Four components combine to define the timing of debris pile ignition and the burn duration (length of allowable burning), specifically, open burning division, smoke sensitivity zone, venting forecasts, and setbacks.

There are five acceptable divisions within OBSCR under which open burning can occur, two of which are likely to be employed under the Project:

1. Division 1 – High, Medium and Low Smoke Sensitivity Zones.
2. Division 5 - Air Curtain Incinerators.

³³ BC Reg. 405/19, s. 15 (a) and (b)

4.5.1 Division 1 – Open Burning by High, Medium, and Low Smoke Sensitivity Zones

Table 3 outlines the specific burn criteria for burning in high, medium and low sensitivity zones.

Table 3. Burn Criteria for Open Burning Completed Under Division 1 by High, Medium, and Low Smoke Sensitivity Zones³⁴.

	Division 1 – Open Burning by Smoke Sensitivity Zone				
Sensitivity Zone	High (HSSZ)	Medium (MSSZ)	Low (LSSZ)		
Setback Distances (m)³⁵	Residences and Businesses: 500 Schools, hospitals, and community care facilities: 1000				
Burn Duration	< 2 days	< 1 day	< 4 days	< 1 day	< 6 days
Venting Indices Required	Good (Day Open Burning Starts), Fair or better (Second day of burning)	Good	Good (Day Open Burning Starts), Fair or better (Second day of burning)	Good	Good or Fair (Day Open Burning Starts) and Good or Fair (for the Second Day of Open Burning)
Ignition Time	Not earlier than 1 hour after sunrise				During the burning period
Period for Igniting Piles of Unlit Vegetative Debris	Between 1 hour after sunrise and 4 hours before sunset on the day that open burning starts	During the burning period	Between 1 hour after sunrise and 2 hours before sunset on the day that open burning starts	During the burning period	During the burning period
Period for Adding Unlit Vegetative Material to Ignited Piles	Between 1 hour after sunrise and 4 hours before sunset on the day that open burning starts	During the burning period	Between 1 hour after sunrise and 2 hours before sunset on the day that open burning starts and on the second day of open burning	During the burning period	During the burning period
Burning Ends³⁶	4 pm on the second day of open burning	4 pm or two hours before sunset, whichever is later, on the same day open burning starts	4 pm on the fourth day of open burning	4 pm or two hours before sunset, whichever is later, on the same day open burning starts	4 pm on the sixth day of open burning

³⁴ BC Reg. 405/19, ss. 19 - 22

³⁵ BC Reg. 405/19, s. 13(2). Open burning is allowed within modified setbacks, as per Section 13 (2), OBSCR 405/19. Additional burn criteria apply and are outlined in Table 4.

³⁶ "end", with regards to when open burning ends, as defined in BC Reg. 405/19 Part 1 and in the glossary.

	Division 1 – Open Burning by Smoke Sensitivity Zone			
Sensitivity Zone	High (HSSZ)	Medium (MSSZ)		Low (LSSZ)
Seasoning³⁷ Requirements	Vegetative debris must be seasoned	The amount of seasoned vegetative debris must be maximized	Vegetative debris must be seasoned	The amount of seasoned vegetative debris must be maximized
Ventilation Forecast Requirements	Ventilation forecast for the area must be obtained on the day, but before burning starts			
CVF Requirements	CVF for the area must be obtained on the day before or on the day, but before burning starts			

³⁷ As defined in BC Reg. 405/19 Part 1 and in the glossary.

Despite the setbacks detailed in Table 3, when completing open burning as per Division 1, open burning may be carried out within modified setbacks, if the additional burn criteria conditions laid out in Table 4 are met with respect to the open burning.

Table 4. Burn Criteria for Open Burning in Modified Setbacks.³⁸

	Modified Setbacks (Division 1 – Open Burning by Smoke Sensitivity Zone)
Setback Distances (m)	Residences and Businesses: 100 Schools, hospitals, and community care facilities: 500
Piling	Vegetative debris must be piled before it is open burned
Pile Dimensions	Largest horizontal dimension is not greater than twice the height (e.g. for a pile 4 m tall, horizontal dimension must be ≤ 8 m).
Reporting	Written record of the dates the vegetative debris was piled is available to an officer upon request.
Pile Composition	No stumps; largest part of each separate portion of the vegetative debris has a diameter < 50 cm; vegetative debris is seasoned vegetative debris
Notification (not later than 24 hours in advance of starting open burning)	All reasonable efforts are made to give notification of open burning to: occupants of residences, businesses, schools, hospitals and community care facilities within 500 m. Notification to the persons who manage the school, hospital or community care facility.
Ventilation Forecasts	Good
Ignition Time	Not earlier than 1 hour after sunrise
Burning Ends	4 pm or two hours before sunset, whichever is later, on the same day open burning starts
Other Ventilation Requirements	<ul style="list-style-type: none"> • Ventilation forecast for the area must be obtained on the day, but before burning starts, or • CVFs for the area must be obtained on the day before or the day of burning, but before burning starts.

4.5.2 Division 5 – Open Burning Using Air Curtain Incinerators

Open burning using air curtain incinerators is exempted from setbacks, as outlined in Section 4.4 and Table 1, as well as piling and seasoning requirements. Setbacks specific to the use of air curtain incinerators are dependent upon meeting open burning criteria and are outlined in Table 5.

³⁸ BC Reg 405/19, s. 13(2)

Table 5. Burn Criteria for Open Burning Under Division 5, Using Air Curtain Incinerators.³⁹

	Distance of open burning from values (m)	Distance of open burning from values (m)
Neighbouring buildings residences (including seasonal residences in use), and businesses	100 - 1000	1000+
Nearest property line of hospitals, schools, community care facilities, and identified sensitive receptors.	500 – 2000	2000+
Opacity ⁴⁰ requirements	Does not exceed 40% during the 30-minute period following the start of open burning and does not exceed 15% for more than 5 consecutive minutes during any other 30-minute period during open burning	
Vegetative debris stacking	Vegetative debris is not stacked above the air outlet of the air curtain incinerators.	
Operational continuity	Air curtain blowers operate continuously until the incinerators cease combustion of the vegetative debris or until all the vegetative debris has been reduced to ash	
Ignition Time	Not earlier than 1 hour after sunrise	N/A
Timing of addition of vegetative debris	From one hour after sunrise to sunset	N/A
Ventilation forecast	Fair or better for the day open burning is carried on; a Poor forecast for the day requires that no more vegetative debris is ignited	N/A

4.5.3 Venting Forecasts

Venting forecasts are issued every morning for the current and next day. The forecasts include the ventilation (or venting) index (VI), wind speed, and mixing height to help guide burning operations. Forecast venting conditions for the day of the burn and the following day, if applicable, must meet the minimum venting requirements laid out within the OBSCR and in the relevant burn criteria table (Table 3, Table 4, Table 5).

BC Air Quality defines VI as; “a numerical value related to the potential of the atmosphere to disperse airborne pollutants, such as smoke from a prescribed fire. It is based on both the current wind speed in the mixed layer and the mixing height. The mixed layer is the surface layer of air that is turbulent and well mixed. The mixing height is the thickness of this mixed layer.” Greater wind speeds and thicker mixing heights will result in higher venting indices. It should be noted; however, when wind speeds are too high, ground level mixing may be reduced.

A VI of 0 means that there is no ability for the atmosphere to disperse smoke, whereas a VI of 100 means excellent smoke dispersion; the persistence of smoke from open burning is tied

³⁹ BC Reg 405/19, s. 28

⁴⁰ As defined under BC Reg 405/19, s. 28(1) and the glossary.

directly to atmospheric venting conditions. The numerical values are categorized into three ranges: poor, fair, and good (Table 6). Category boundaries may differ in some jurisdictions; the ventilation forecast provides both the numerical value, as well as the ventilation category. Regulatory requirements outline minimum requirements for ventilation category.

Table 6. Venting Indices

Venting Index Numerical Rating	Ventilation Category
0-33	Poor
34-54	Fair
55-100	Good

4.5.3.1 Venting Forecast Sources

There are three acceptable sources for daily venting forecasts: custom venting forecasts (CVFs), Environment Canada regional forecasts, and qualified independent forecasters (details for each source are found in the following subsections). The source of daily forecasts for burning under this SMP will be CVFs, with few exceptions as noted below.

Custom ventilation forecasts must be obtained by a custom ventilation forecaster, as per OBSCR.⁴¹

There may be times when a CVF for the burn area is not available. In the circumstance that CVFs are unavailable, contractors shall utilize the Environment Canada ventilation forecasts. Contractors must record the daily forecast and source, as well as results of test burn, if applicable. More information on recording and reporting is found in Section 5.

In summary, the source for daily ventilation forecast shall be used in the following order:

1. CVF subscription service, then
2. Environment Canada regional forecast.

It is not allowable to select the forecast that is the most favourable for operations or that best suits burning objectives.

A retained, independent, MOE-approved forecaster would replace the CVF subscription service for ventilation forecasts listed above.

Custom Venting Forecasts

To encourage the best dissipation of smoke, burning under this smoke management plan will use custom venting forecasts prepared by a custom ventilation forecaster. Custom venting forecasts are tied more closely to specific geographic locations than Environment Canada forecasts which are prepared for a larger regional area. For this reason, custom venting forecasts are generally thought to be a more accurate choice than Environment Canada venting indices, which often can result in a forecast which is either too strict or too lenient for those locations which are not well-represented by the average area or region for which the forecast was prepared.

⁴¹ BC Reg 405/19, s. 16

The provincial fire centre weather forecasters are approved by the MOE and shall be retained by the contractor through subscriptions for service to provide custom venting forecasts. Custom forecasting subscriptions are generally available for the fall burning season. To set up subscription and receive MOE-approved CVFs, the contractor shall contact the regional MOE contact (see section 7.3 Key Contacts).

The contractor shall provide the following information to the forecaster, where burning is anticipated: Burn Registration Number, location, latitude /longitude, elevation / elevation range, and approximate number of piles.⁴²

Environment Canada Forecasts

The Environment Canada daily venting indices for the Fort St John Zone can be found at: <https://www2.gov.bc.ca/gov/content/environment/air-land-water/air/air-pollution/smoke-burning/ventilation-index> or by phoning 1-888-281-2992 (See Section 7.3).

Independent Qualified Forecasts

BC Hydro may hire an independent, qualified forecaster to provide custom venting forecasts. It is required that all independent forecasters meet the OBSCR definition of custom ventilation forecaster and are approved by the MOE Director in advance of any burning activity which depends upon their forecasts.⁴³ The first step in forecaster approval is contacting the regional MOE contact (See Section 7.3).

If either BCH or a contractor retains an independent forecaster, the forecasts will take the place of the CVF subscription service. Documentation of MOE approval must be recorded and kept on file.

4.5.4 Burn Duration / Burning Period

The burning period is the time between ignition and burn end, as outlined in the applicable burn criteria. Burn 'end' for pile burning means the point in time when each pile of vegetative debris has ceased flaming and is emitting smoke from no more than 10% of its burnt surface area.⁴⁴

Smoke release monitoring is the monitoring of burning activities in accordance with burn duration commitments, based upon smoke sensitivity area, setback, and Division under which open burning is occurring. Burn duration commitments are detailed in Table 3, Table 4, and Table 5. Smoke release monitoring and tracking is detailed in Section 6.1.

Burn duration is measured per pile.⁴⁵ Each pile that is ignited must individually adhere to burn duration / burn period.

⁴² A general rule of thumb which may be helpful for estimating number of piles is: $(NAR * 2 = \# \text{ of piles})$, where NAR = Net Area to be Reforested (ha) = Area Harvested / Cleared.

⁴³ BC Reg 405/19, Part 1 and pers. comm. Gail Roth, Ministry of Environment, August 3, 2017.

⁴⁴ BC Reg 405/19, Part 1

⁴⁵ Personal communication (email), October 10, 2019 from OBSCR@gov.bc.ca.

The regulation allows for vegetative debris to be open burned up to 5 km from the point of origin. In the case that longer burning period or more flexibility on venting conditions, vegetative debris originating within the HSSZ may be moved to the MSSZ, within 5 km, for open burning.

4.5.5 Change in Burning Conditions

Should weather conditions change such that local airflow or atmospheric mixing is causing or likely to cause make smoke dispersion inadequate, specifically to negatively impact a nearby population or work camp or to be a navigational hazard at an airport or on highways by significantly reducing visibility, debris may not be added to an open burn until conditions improve and is no longer causing to have effects described as above.⁴⁶

4.6 Burn Registration

4.6.1 Category 3 Piles

Prior to the initiation of any Category 3 burns, the contractor shall obtain a Burn Registration Number (BRN).⁴⁷ BRNs are obtained through the BC Wildfire Service at **1.888.797.1717**. BRNs are valid for one parcel and for a two-week period after which time they may be re-issued through the same process. A separate BRN is required for each parcel on which open burning is planned. The following information is required in order to receive a BRN: contact information for person initiating burn (contractor information), parcel description / coordinates of open burning (center point of area for parcels with multiple piles), the number of piles to be burned under the BRN, type of material to be burned, and any other information relating to the proposed open fire that the official or the person answering the telephone number requires.⁴⁸

The following is required for compliance with the BRN⁴⁹: check venting indices (CVFs) prior to ignition; comply with OBSCR, local bylaws, local and provincial fire bans, the *Wildfire Act* and Wildfire Regulations. Following this SMP will ensure compliance with the BRN.

BRNs must be recorded and kept on site during burning activities. Details regarding required contractor recording and reporting are found in Section 6.2.

4.6.2 Category 2 Piles

Category 2 burns do not require a BRN. When completing Category 2 burns, the contractor shall record size (height and width), number of piles burning concurrently (two or fewer), and number of piles burned through the day. Piling and burning may be done concurrently, under the condition that pile number or size do not exceed maximums allowed for Category 2. Details regarding required contractor recording and reporting are found in Section 6.2.

⁴⁶ BC Reg 405/19, s. 15

⁴⁷ BC Reg. 38/2005, s. 22(1)

⁴⁸ BC Reg. 38/2005, s. 24(1)

⁴⁹ Pers. comm. Operator at BCWS BRN phone number.

Category 2 burns as part of industrial operations must adhere to all OBSCR regulations, and therefore contractors must: check venting indices (CVFs) prior to ignition; comply with OBSCR, local bylaws, local and provincial fire bans, the *Wildfire Act* and Wildfire Regulations.

4.7 Records and Reporting

OBSCR requires all Category 3 and open burning with use of an air curtain incinerator record and maintain specific information, with respect to open burning.⁵⁰ The documentation must be kept on site and available for the duration of the open burning, retained for a period of one year from the start of burning, and submitted to the MOE upon request. Details on required information to achieve regulatory compliance are found in section 6.2.

5.0 Smoke Reduction – Best Management Practices

Best Management Practices (BMPs) provide guidance to debris management contractors and BCH monitors for opening burn activities and smoke management to help achieve smoke management objectives and compliance with regulatory requirements. The OBSCR requires all reasonable efforts are taken to minimize the amount of smoke emitted when open burning.⁵¹ The strategies and techniques within the BMPs of this section shall ensure that this requirement is met. Specific regulatory requirements outlined in the OBSCR will be identified within the BMPs, where appearing.

5.1 Seasonal Burn Planning

5.1.1 Burn Season

Typically, the late summer / early fall offers better burning conditions in terms of fire weather indices and longer daily average of appropriate venting (i.e. longer days). Additionally, this window provides the best window to avoid “holdover” fires; fires that do not extinguish during the winter months can retain the potential to ignite dead grass and forest fuels in the early spring fire season (usually April and May). Fires in late summer and fall have the most time to extinguish on their own in the winter months. Fire hazard abatement monitoring is detailed in Section 6.1.

Burning outside the usual burning season (as noted above) is acceptable, given that the regulatory requirements as set out in this SMP are followed, regardless of seasonal timing (*i.e.* open burning is compliant with all applicable burn criteria, such as venting indices are checked and favourable, there are no provincial or local fire prohibitions, BRN is received, if applicable, and burns comply with all provincial legislation and regulations (OBSCR, *Wildfire Act* and Wildfire Regulation).

5.1.2 Burning Prioritization

Any burning within high smoke sensitivity zones should be prioritized to take advantage of the best venting conditions and longer daytime hours to allow for optimum conditions in those areas closest to populations.

⁵⁰ BC Reg 405/19, s. 31.

⁵¹ BC Reg. 405/19, s. 11

5.1.3 Sensitive Time Periods

Seasonal scheduling of burning activities will consider regionally important time periods, for example periods with high recreational activity or periods with known Aboriginal use based on the results of ground-truthing exercises. During, and two days prior to, sensitive time periods, no debris piles will be ignited.

Based on regional recreation activity, the following periods have been identified as sensitive:

- long weekends in May, July, August and September
- Aboriginal use periods – may be determined based on ground-truthing exercises and through the First Nations notification process. Burning practices may require modification based upon responses received from notification. For details regarding burning notification, see Section 7.1.

5.2 Debris Pile Construction and Seasoning

Proper pile construction techniques will aid in the achievement of a high intensity burn that is capable of consuming itself in the shortest time possible and achieve easy and safe ignition.

5.2.1 Pile Size, Shape and Components

Pile construction shall consider the following:

1. Piles should be roughly conical (haystack or bell-shaped) with a width to height ratio of roughly 2:1. In all cases, piles must be stable.⁵²
2. Large piles typically burn hotter and cleaner than smaller piles. Efforts should be made to make fewer, larger piles, while considering crew safety and meeting the smoke release period criteria. Ideally, pile height of 4 m, or higher, is recommended.
 - a. Category 2 burns are a maximum size of 3 m in width and 2 m in height (maximum of two piles burning concurrently per parcel).
3. Coniferous slash often burns better than deciduous (aspen/cottonwood) slash. Efforts should be made to mix fuel types, where practicable.
4. To ensure the continuity of the burn, piles should contain a mixture of debris sizes (mixture of fines with larger diameter material) with as few voids as possible.⁵³
5. To achieve efficient ignition, place smaller diameter fuels at the base to create an ignition zone, ideally 2 m thick.

⁵² To help achieve compliance with BC Reg. 405/19, s. 11(b)

⁵³ To help achieve compliance with BC Reg. 405/19, s. 11(b)

- a. For Category 2 piles, create a good mixture of small and large diameter fuels throughout the pile. Due to reduced size, a 2 m ignition zone is neither ideal, nor feasible.
6. Minimize soil content that may be mixed in with vegetative debris; break root wads up to remove any soils/rocks prior to piling and place pieces higher on the pile.⁵⁴
 7. Within the high sensitivity smoke zone, all vegetative debris burned (piles) must be seasoned, such that the pile is 30% or less moisture content, originates from dead standing timber, or has been piled for a minimum of 4 months⁵⁵. Pile covering is an option to keep fuel moisture content low; remove covering prior to burning.
 8. Within the medium sensitivity smoke zone, within each pile maximize the amount of vegetative debris which is seasoned vegetative debris; piles should be seasoned until they can easily combust. Ideally seasoned piles would be 30% or less moisture content or piled for at least 4 months.⁵⁶ Pile covering is an option to keep fuel moisture content low; remove covering prior to burning.
 9. Establish a fuel break around each pile.⁵⁷ Determining necessary fuel break width and type should consider, but not be limited to, the following variables: pile size, proximity to adjacent fuels, type of fuels burning and adjacent, fire weather, slope, and aspect. Fuel breaks are defined as: 1) a barrier or a change in fuel type or condition, or 2) a strip of land that has been modified or cleared.⁵⁸
 - a. Examples of potentially acceptable fuel breaks, depending on the variables list above, may include: frozen soils to a depth of one foot, snowpack on frozen soil, or removal of all combustible material / biomass to mineral soil to a width determined to be sufficient for conditions.
 10. Maintain fuel breaks while the fire is burning and there is a risk of the fire escape.⁵⁹

Additional considerations:

11. Do not construct piles in low, water-receiving sites. Low water-receiving sites are defined as any location where the water table is at the soil surface such that fuels are not be able to season or would not be able to achieve ideal fuel moisture content for burning. Areas to avoid may include swales, wetlands, low-lying flood plains, or areas of seepage. This is to ensure that fuels achieve the desired fuel moisture content and therefore burn hotter and with less smoke emission. Piles should be built in locations which are dry (water table not at the surface) for more than 4 consecutive months from spring to winter, not including moisture received during

⁵⁴ BC Reg. 405/19, s. 11(a)

⁵⁵ BC Reg. 405/19, s. 19(a)

⁵⁶ BC Reg. 405/191, s. 1(c)

⁵⁷ BC Reg. 38/2005, s. 22 (1)

⁵⁸ BC Reg. 38/2005, s. 1 (1)

⁵⁹ BC Reg. 38/2005, s. 22 (1) (f)

precipitation events, and which are not likely to have the water table at the surface during the desired burning window.⁶⁰

12. Do not construct piles within riparian reserve zones (RRZ)⁶¹, unless directed by BCH due to operational or topographic limitations. Any machine work will be conducted in accordance with CEMP Section 4.5 (15 m machine-free riparian buffer from the Ordinary High Water Mark).
13. Do not construct piles within the minimum setbacks outlined in Table 1, unless open burning using an air curtain incinerator.
 - a. Setbacks for air curtain incinerators can be found in Table 5
14. Do not pile where burning will negatively impact (scorch) the timber edge or retained trees. Larger, machine-built piles will require larger setbacks, whereas smaller, hand-built piles can be closer.
15. Avoid introducing soils and other non-combustibles into the pile.⁶²

5.3 Pre-Burn Protocols

5.3.1 Collate Burn Plan Information

Prior to the burning season, contractors shall collate information related to the smoke sensitivity zone and the approximate number and location (coordinates) of the piles slated for burning. This information is required in obtaining Burn Registration Numbers (BRNs) (see Section 4.6). This information must be available for BCH upon request.

5.3.2 Venting Forecasts

Confirm source of venting forecast: custom venting forecast, whether through a subscription service provided by a MOE pre-approved forecaster or by retaining a qualified independent forecaster, or regional forecasts from Environment Canada. See Section 4.5.2 for details regarding venting forecast sources and acceptable utilization.

5.3.2.1 Limitations of Venting Index and Forecasts

Strict adherence to the venting indices (the computed value or category) may conflict with the practical objective of minimizing potential impacts of smoke. There are limitations to the venting index calculations, which shall be considered by the contractor prior to ignition. For example, wind direction and proximity to potential values impacted are not incorporated into the venting index. There may be additional impacts from changing weather, such as changing wind patterns

⁶⁰ To help achieve compliance with BC Reg. 405/19, s. 11(c)

⁶¹ BC Reg 41/2016, s. 1 (1)

⁶² To help achieve compliance with BC Reg. 405/19, s. 11(a)

and rain/snow events that may result in undesirable burning conditions or evening and overnight venting conditions. It is important to consider wind direction and mixing heights.

Practical Application

The following adaptations shall be considered by the contractor prior to ignition, as appropriate:

- If wind direction is not favourable and smoke is likely to impact populations, highways, or airports, burn instead in locations where wind direction works in favour of burn and smoke travel.
- Consider moving to remote piles when forecaster confidence in continued good venting is low.
- Consider prioritizing any high smoke sensitivity area burns when forecaster confidence in continued good venting is high.
- Lower mixing heights will not have the capacity for large volumes of smoke, suggesting that the ignition of a large number of piles should be avoided. Ignite fewer piles in these situations to reduce overall volume of smoke emitted.

Despite acceptable venting forecast (e.g. good and fair) advancing weather conditions can result in a rapid decline in venting leading to unacceptable levels of smoke.

Venting Forecast Validation

Venting forecast validation can be completed through ignition and monitoring of a test pile. After test pile ignition, monitor the performance of the burn for 15-30 minutes relative to:

- Fire intensity.
- Smoke release (direction, dispersion, quantity and relation to important infrastructure such as highways, airports, sensitive receptors, and population centres).
- Potential for escape to adjacent piles or slash.

With confirmation that the test pile is burning as planned, continue with the daily burn plan and monitor pile burning performance throughout the day. Where significant reductions in burn performance are noted, burning shall be halted or the burn plan revised to increase burn performance to an acceptable level. Documentation of venting forecast validation, results, and pile performance monitoring are the responsibility of the contractor. See Section 6.2 for details.

During Burning

If, during burning, it is determined that smoke dispersion is not ideal, potential adjustments to daily burn plans could include one, or more, of the following strategies:

1. Ceasing to add new debris to the pile earlier in the day or imposing earlier end time for ignition period to allow for more daytime burning.
2. Using accelerants to promote more rapid pile ignition.
3. Using forced air mechanisms to encourage hotter fires and more complete combustion.

4. Re-piling slash to improve pile construction.
5. Extinguishing burn pile.

5.3.3 Communication with Forecasters

The contractors shall communicate with the custom venting forecasters regarding burn registration information. To maximize the effectiveness of the custom venting forecast, work with the forecaster in identifying any additional information that may be required to ensure the most accurate forecasts possible. This information may include specific pile elevation and timing related to the issuance of forecasts. Forecast limitations should be discussed with the forecaster and documented in the daily burn log, as applicable.

5.3.4 Training

Desired open burning outcomes are much more likely to be achieved if burning crews have the appropriate level of experience and training. All supervisors, ground crews, and machine operators shall be appropriately trained in regulatory requirements, BMPs, safe work protocols, and Standard Operating Procedures and must be competent in operational fire and fire suppression activities. Contractors must retain records of training and certification on site and provide to BCH upon request. The following is a non-exhaustive list of areas of competency.

- Wildfire Regulation requirements;
- OBSCR requirements;
- Site C Smoke Management Plan –smoke management strategies and BMPs;
- burning criteria;
- burn pile construction;
- burn pile ignition;
- firefighting;
- wildfire reporting;
- fuel handling, storage and spill reporting; and,
- emergency response procedures (ERPs).

5.3.5 Environmental Considerations

The Contractor's Qualified Environmental Professional (QEP) shall survey each burn pile prior to light-up to confirm they are not actively being used as an animal den. QEPs may consider the use of drones for den surveys. Den surveys shall have validity duration of 7 days, so if a pile is not lit within this validity period the QEP must complete another den survey prior to light-up or provide environmental rationale in weekly environmental monitoring reports justifying the duration that the burn pile can be considered clear of animal dens. During the bird nesting window (see the CEMP), and when Contractors intend to burn piles, the QEP shall also survey each pile to confirm it is absent of active bird nesting activity. These bird nest surveys shall have validity duration of 3 days, so if a pile is not lit within this time period the QEP must complete another nest survey prior to light-up. The results of these den and nest surveys (as appropriate) shall be available on-site at all times during burn activities and included in weekly reporting (see Section 6.2). Any pile containing an active den or nest must be clearly marked in the field and mapped and this must be communicated to crews in a documented tailboard so they can easily identify it and not light it.

5.4 Light-Up Procedures

Pile ignition may occur by ground crews or by aerial ignition (helicopters). It is critical to ensure that all the logistics relative to the burning plan have been addressed prior to ignition. In order to ensure this, a pre-burn checklist (go no-go safety checklist) and an ignition plan must be completed.

5.4.1 Pre-burn Checklist

The pre-burn checklist should include all critical safety, regulatory, and operational variables. It is the responsibility of the contractor to ensure that pre-burn checklists include smoke management variables, as well as ensure compliance with other directly relevant legislation, such as the *Wildfire Act* and Wildfire Regulation. A pre-burn checklist must be completed each day one or more debris piles are ignited and separate checklists must be generated for each area covered by a venting forecast and for burning in separate smoke sensitivity zones (e.g., separate pre-burn checklists are required for burns in a custom venting forecast area that spans two or more smoke sensitivity zones). In the event that one or more boxes on the pre-burn checklist are unable to be 'ticked', ignition must not occur.

Table 7 provides an example pre-burn checklist for operators.⁶³

⁶³ Pre-burn checklist adapted from a variety of sources, including: BCTS Strait of Georgia Open Burning Checklist and BCWS Burn Plan Template.

Table 7. Example Open Burning Pre-Burn Checklist for Category 2 and Category 3 Fires. The Pre-Burn Checklist may be Modified or Adapted to Better Suit Aerial Ignitions.

Parcel Description:		Project Geographic Location:	
Latitude (UTM):		Longitude (UTM):	
Category Area:		Burn Category:	
Completed by: _____		Date: _____	
Company Name: _____			
Contact Phone Number(s) _____ (cell / office / other _____) _____ (cell / office / other _____)			
MFLNRORD Burn Registration Number (required for Category 3 burns): _____ N/A Call 1-888-797-1717			
ALL forest fires must be reported immediately to: 1-800-663-5555, or *5555, or to a regional manager, district manager, designated forest official, or peace officer. The BCH contact must also be notified as soon as possible.			
This checklist is intended for informational purposes only. It is not legal advice. Regulatory obligations are found in the <i>Wildfire Act</i> and Regulation and the <i>Environmental Management Act</i> and Open Burning Smoke Control Regulation.			
Definitions from Wildfire Regulation (2005) Section 1			
Category 2 Open Fire: "...open fire that (a) burns material in one pile not exceeding 2 m in height and 3 m in width, (b) burns material concurrently in 2 piles each not exceeding 2 m in height and 3 m in width, or (c) burns stubble or grass over an area that does not exceed 0.2 ha." (See Wildfire Regulation, S. 21)." Category 3 Open Fire: "...open fire that burns (a) material concurrently in 3 or more piles each not exceeding 2 m height and 3 m in width, (b) material in one or more piles each exceeding 2 m in height or 3 m in width, (c) one or more windrows, or (d) stubble or grass over an area exceeding 0.2 ha." (See Wildfire Regulation, S. 22)." 			
'NO' = NO IGNITION			
Element	Yes / No / N/A	Comments	
PLANNING			
Has smoke sensitivity zone been determined? Is it understood how the smoke sensitivity zone impacts operational activities (burn criteria)?			
Are the piles sufficiently seasoned, according to the smoke sensitivity zone? <ul style="list-style-type: none"> • HSSZ – piles were constructed 4 months ago or more, debris originates from dead standing timber, or are ≤30% moisture content. 			
Has piling been completed according to the SMP such that burning can be completed safely and effectively (including surrounded by a fuel break) and such that the pile can be consumed and burning end within the applicable burn duration? If no, re-pile or allow to season.			
Are pile locations >500 m from any inhabited residences or business and >1,000 m from schools in session, hospitals, continuing care facilities, and identified sensitive receptors (unless burning under the burn criteria conditions stipulated for modified setbacks)?			
Are pile locations outside riparian reserve zones?			
Are piles located according to BMPs: 1) outside of low-lying and water receiving areas; 2) sufficient distance from standing timber to avoid scorching; 3) sufficient distance from surrounding bush to avoid scorching?			
Is a site map available for workers on-site, as well as for arriving responders in the event of an escape? Maps should identify water sources, access/egress, potential helicopter landings, etc.			
A Qualified Environmental Professional has surveyed the piles and confirmed they are free of active animal dens and active migratory bird nests.			
Are ERPs completed and on-site?			
Are there any applicable burning bans or restrictions? Check with BCWS and record fire danger rating.			

Is there a means to report a wildfire on site? (cellular, satellite phone, or radio contact)		
Does the venting index/venting forecast meet OBSCR (day of burn and following day)? Record rating.		
Are there any Air Quality Burning Bans? Check with MOE. Document communications.		
Burn Registration Number received (Category 3 only)?		
Legal obligations under the <i>Wildfire Act</i> and Wildfire Regulation reviewed and understood?		
Legal obligations under the Environmental Management Act and Open Burning Smoke Control Regulation reviewed and understood?		
BCH SMP reviewed and understood?		
Do the piles include only clean, woody waste / debris?		
Have all notifications been completed and recorded in the notification log?		
Have you checked with the local Fire Department and Municipality for local Bylaws that pertain to open fires and permits which may be required?		
Has the crew briefing been completed?		
WEATHER		
Have you checked current and forecasted wind conditions? Are the current and forecasted winds acceptable for burning? If the wind is strong enough to carry sparks to other combustible material, do not burn.		
Check the detailed weather information, including Fire Danger Class, Temperature, Relative Humidity, Precipitation and Wind Speed for work site.		
Ensure that a system is in place for site crew and supervisor to keep notified of current and expected weather forecasts. (Keep records)		
Have site conditions that could lead to potentially dangerous fire behavior or increase probability of spot potential or escape, including slope, aspect, topography, fuels, access and egress, been fully considered?		
Have you checked wind direction and confirmed that wind direction is favourable (will not negatively impact nearby populations and will not pose a hazard at airports or provincial highways by significantly reducing visibility)?		
Was a test pile lit and results recorded?		
SAFETY / SUPPRESSION CAPABILITIES		
Is crew competent and trained to complete operational fire and fire suppression activities? Keep training logs and certifications on file.		
Has all staff on-site been trained on a suppression/response plan in the event of an escape?		
Has a communication plan been established for reporting escaped fire or other emergency situations?		
Are available resources known, able to be contacted, and aware of their responsibility to respond if contacted for containment of potential escapes? And does the list of resources meet the requirements of Wildfire Regulation based on Category of fire?		
Have sources of water for fire suppression been identified. If none available, develop a contingency plan.		
Ensure key contact information for reporting emergencies is included in the ERP.		
Is adequate suppression equipment available at the burn area of a type and capacity adequate for fire control if a fire escapes?		
Are adequate personnel on site to ensure that the fire does not exceed the capacity of the persons, firefighting tools and heavy equipment on site for timely action to prevent fire from escaping?		
Is there a patrol on site equipped with at least one firefighting hand tool and who will immediately carry out fire control, if practicable, and who has the means to report the fire and is aware of this responsibility?		
Crew members have adequate PPE and fire suppression tools in good working order.		

5.4.2 Ignition Plan

A daily ignition plan shall be developed and provided to BCH prior to each day's ignition activities. It shall include, but not be limited to, personnel; ignition method, tactics, and procedures; ignition location (e.g. GPS points of piles to be ignited or extents of ignition); and flight plan.

5.4.3 Daily Ignition Period

The daily ignition period is the recommended time of pile ignition and has been designed to coincide with the time of day where venting conditions are typically best and to ensure that there is sufficient time remaining after ignition for the burn to consume most of the pile (Table 8). Following daily ignition periods will increase the potential for burns to occur during the time of day when venting is most favourable and minimize the release of overnight smoke when venting is generally less favourable.

Table 8. Recommended Daily Ignition Period

Smoke Sensitivity Zone	Venting Forecast (Day of Ignition)	Venting Forecast (Day After Ignition)	Daily Ignition Period
High	Good	Fair or Better	1-hr after sunrise to 4-hr before sunset ⁶⁴
Medium	Good	Fair or Better	1-hr after sunrise to 2-hr before sunset ⁶⁵
Low	Fair or Better	Fair or Better	1-hr after sunrise to 2-hr before sunset

5.4.4 Pile Ignition

Pile ignition shall conform to the following:

1. Ignition should occur on the upwind side of the pile.
2. Ignition should be low on the pile.
3. To support rapid ignition, select a portion of the pile with the most ideal mixture of piece size and distribution (i.e. choose a portion of the pile that most accurately represents the characteristics of the piles, as described in Section 5.2.1).
4. When fine fuels are damp / green or when slash pile lacks the appropriate distribution of piece sizes, consider using propane torches or fuel gel and forced air mechanisms to encourage a better and hotter ignition. Alternately ignition can wait until fuel moisture conditions are such that an efficient ignition and burn can be achieved.
5. When aerial ignition is used, all ignitions shall follow the safe work procedures and best practices of the helicopter company and the situational awareness and judgment of the pilot.

⁶⁴ BC Reg 405/19, s. 20 (d)

⁶⁵ BC Reg 405/19, s. 21 (c)

6.0 Monitoring and Tracking

6.1 Monitoring

Monitoring of pile burning will be undertaken at three levels; smoke release, debris reduction and hazard abatement.

1. *Smoke Release*

After the allowable burning period ends, piles will be inspected for compliance with the burn duration. If, at the end of allowable burn duration, the pile is found to be emitting smoke from more than 10% of its burnt surface area⁶⁶ (or with the use of an air curtain incinerator, the burn is emitting smoke from more than 10% of the base of the air curtain incinerator), then the pile will be extinguished (debris broken up to achieve burn end).

In the event that debris reduction objectives have not been met at the end of the burn duration, available options include and may implemented, at the discretion of BCH:

- extinguish the pile and consider all operations for the pile to be complete;
- re-pile to facilitate cleaner burning and reignite under a new burning period with acceptable venting and according to the relevant burn criteria; or,
- buck any long pieces to a length <4 m.

New piles will be considered a new burning period and must comply with this SMP and regulatory requirements as a new burn.⁶⁷

Under all scenarios, BC Hydro and the contractor shall review the contributing factors to a burn which exceeds the burn period and shall make appropriate compensatory changes to subsequent burn plans.

It is the contractors' responsibility to ensure compliance with burn periods. The contractor shall document compliance and submit documentation to BCH weekly with the burn tracking requirements (see 6.2.1 for details).

2. *Debris Reduction*

Debris reduction shall be assessed to ensure that the appropriate reduction in debris mass has been achieved. If it is deemed that the level of debris reduction is not acceptable, BCH may determine that the pile shall be: 1) extinguished, re-piled and ignited again; 2) bucked into lengths shorter than 4 m; or, 3) left as-is.

3. *Hazard Abatement*

⁶⁶ As defined in BC Reg 405/19, s. Part 1 and the glossary.

⁶⁷ Personal communications: Earle Plain Air Quality Meteorologist email October 29, 2019.

For the purposes of hazard abatement, piles will be monitored to ensure that the piles are completely extinguished. Category 3 fires must be extinguished by the date specified by the official or person who issued the BRN.⁶⁸ Contractors must be able to display that each individual pile is out. This can be achieved by cold trailing by hand or assurance by a thermal scan.

Depending on seasonal timing of burns, there may be potential for holdover fires to pop up in the spring. Pile monitoring in spring shall be completed by the contractor to ensure holdover fires do not cause unintended ignitions or burns. This risk is highest in spring after snowmelt and prior to green-up.⁶⁹ Infrared scanning shall be completed immediately after the site is snow-free and prior to hazard build up. Site conditions shall be monitored to determine appropriate timing for infrared scanning, rather than relying solely on calendar timing to schedule scans.⁷⁰

6.2 Tracking

Tracking, or documentation, is required to demonstrate diligence to the process, to demonstrate compliance with legislation and commitments, and to help track efficacy and improve performance. Tracking documents produced through activities related to this SMP include, but are not limited to:

- Burn tracking form;
- Pre-burn checklist;
- Ignition plan;
- Burn period / smoke release form;
- Den and bird nesting surveys; and,
- Associated photo-documentation of the above.

6.2.1 Burn Tracking

Burn tracking begins prior to ignition and continues through to the time it is confirmed that the fire is extinguished. Burn tracking provides valuable data for continual improvement, helps to achieve compliance with regulations and BMPs, and tracks productivity. It is the contractor's responsibility to:

1. Ensure a pre-burn checklist and ignition plan is completed prior to ignition and provided to BCH upon request (Sections 5.4.1 and 5.4.2, Table 7).
 - a. Note any diversions from ignition plan.
2. Record GPS coordinates of ignited piles, date of piling, and allowable burning duration.
 - a. Pre-ignition, georeferenced photos of piles is recommended (or alternative documentation system of an equivalent and measurable monitoring system developed by the contractor and approved by BCH).

⁶⁸ BC Reg. 38/2005, s. 22 (2) (b)

⁶⁹ Personal communication, Doug Smith, BCWS, Prince George Fire Centre.

⁷⁰ Personal communication, Cliff Laursen, BCWS, Prince George Fire Centre.

3. Complete and submit the Burn Tracking Form daily (Table 9). The form provides details on the progress of the burn plan, documents compliance, and provides information related to burning criteria.
4. Document any changes to ongoing burn plans; note if or how the changes are a direct result from monitoring feedback (Table 9).
5. Complete the burn period / smoke monitoring tracking form (or alternative equivalent documentation system developed by the contractor).
 - a. Record ocular observations and photos related to achievement of burn period per pile.
6. Complete and retain results of den and active-bird nesting surveys (Section 5.3.5).

The daily burn tracking form, burn period / smoke release monitoring documentation, photo-documentation and den and bird nesting surveys shall be submitted weekly to the BCH representative / project supervisor. All other documentation shall be available to BCH upon request.

Table 9. Burn Tracking Form, including an example entry. Ignitions on different parcels, different geographic location or Smoke Sensitivity Zone, or difference in Burn Category (Category 2 / Category 3) would necessitate additional entries or additional forms. An asterisk (*) indicates reporting requirements from the OBSCR.⁷¹

BRN Information		Location			Custom Venting Forecast			Other Information													
*Date / Ignition Period	*Number of Piles	Piles Ignited	Pile Remaining	*Burn Reference #	Parcel Description (Legal, PID, or description)	Latitude	Longitude	Elevation	Smoke Sensitivity Zone	Burn period end	*Venting Source Used	*Venting @ 4 pm Day 1 (VI/ VI Category)	*Venting @ 4 pm Day 2(VI/ VI Category)	Wind speed and direction (Current / Forecasted)	Closest value and direction from burn site	Pile size (height and width)- Category 2 Only	Test Burn (Y/N and results)	Fuel Break (type, width, maintenance)	Change in conditions / update (Time/ Comment)	Change in conditions / update (Time/ Comment)	Additional comments
11/15/19, 10:30am – 11:30am	95	94	1	123456	REM SEC 3 TP 86 R 24212W6M	56. 14 54.36	121.12 58.82	700 m	Medium	11/18/2019, 4:00 pm	CVF	65 (good)	52 (fair)	17 kph, NE / 6kph, N	Fort St John - NE	N/A – Category 3 burn	Y – 9:30am ignition, venting moderate, wind blowing away from town. Clear skies.	6" snow on frozen soils, expanded 2' during burn, watched and no fire spread	11:30 am checked conditions, venting slightly improving, no reduction of visibility.	2:00 pm change in wind speed and direction. Gusting to 35 km, S wind. Burn halted.	Photo documented test burn venting, afternoon venting, and pre-burn piles.

⁷¹ 31(1) Open Burning Smoke Control 405/19

Table 10. An example of an acceptable burn period / smoke release monitoring form.

General information			Smoke release / burn duration monitoring						Debris reduction			Other			
Date / Time of Day	Burn Reference #	Parcel Description (Legal, PID, or description)	Latitude	Longitude	Smoke Sensitivity Zone	Allowable Burn Duration	Pile Ignition Date / Time	Burn period end	% of burnt surface area emitting smoke	Action taken	Follow-up recommended	Pile size (m) (unconsumed vegetative debris remaining)	Piece size (note number and size of pieces >4 m in length)	Follow-up recommended	Additional comments
11/15/19, 3:45 pm	123456	REM SEC 3 TP 86 R 24212W6M	56. 14 54.36	121.12 58.82	Medium	<4 days	11/15/17, 10:30am	11/18/2019, 4:00 pm	~5%	None required; smoke release in compliance with burn end (<10%)	Cold trail or thermal scan to ensure pile is extinguished (spring 2020)	2 m x 3 m x 1 m	1 piece >4 m	None recommended; one piece > 4m will remain due to pile location and limited accessibility	Georeferenced photographs taken; smoke release is visible.

6.2.2 Record Keeping and Submission

It is the responsibility of the contractor to complete, retain, and submit all records created as a result of open burning and implementation of the SMP.

6.2.2.1 Weekly Submission

The following forms (or contractor-developed equivalent) and associated photo documentation shall be submitted weekly by the contractor to the appropriate BCH representative. Records will be saved as pdf files and uploaded to SharePoint.

- Burn tracking form;
- Burn period / smoke release form;
- Den and bird nesting surveys.

6.2.2.2 Upon Request

The following records must be retained and submitted to BCH or MOE upon request.

- Pre-burn checklist;
- Ignition plan.

Daily burn tracking forms must be retained for a period of one year beginning on the start date of open burning and be submitted to an MOE officer upon request.⁷²

6.3 Air Quality Monitoring, Advisories and Burn Bans

The BC Ministry of Environment operates an air quality monitoring station at the North Peace Cultural Centre in Fort St. John. Fine particulates will be monitored at 3 locations (85th Avenue Industrial Lands, Old Fort, and the Site C worker accommodation complex) and monitoring will be completed according to Appendix B - Air Quality Monitoring Program of the CEMP.

The Ministry of Environment (MOE) may issue air quality advisories or burn bans should particulate matter concentrations approach or exceed provincial objectives⁷³. The current provincial 24-hour ambient air quality objectives are as follows:

- Particulate matter <2.5 microns (PM_{2.5}): 25 µg/m³
- Particulate matter <10 microns (PM₁₀): 50 µg/m³

If an advisory and/or burn ban is issued, burn operators are required to adhere to the terms of the advisory and/or burn ban.⁷⁴

⁷² BC Reg 405/19, s. 31(2)(b)(c)

⁷³ BC Reg 405/19, s. Schedule 2

⁷⁴ BC Reg 405/19, s. 30(1)(2)(3)

7.0 Notification and Wildfire Reporting

7.1 Notification

Notifications to key stakeholders will take a multi-layered approach. The contractor shall notify BCH of existence of acceptable burning conditions and intention to ignite up to 24 hours in advance of ignition and not later than 8:00 AM on the day prior to ignition.

7.1.1 Public

Intentions to burn will be included in a biweekly construction bulletin issued by BC Hydro. Additionally, the Contractor will issue notices to groups identified in Tables 9 and 10, preferably within 24 hours of a day with acceptable burn conditions and no later than 8:00 AM on the day a burn might or will occur. Contractors will use messaging approved by BC Hydro for this communication and will cc BC Hydro on all e-mail notifications. Property owners and First Nations will be contacted by BC Hydro.

7.1.2 First Nations

Indigenous groups are to be notified a minimum 30 days' prior to the commencement of burning activities in a given location. This is in order to maintain a consistent standard and to align the notification process with requirements from other permits and licenses issued for the Site C project under the *Wildlife Act* and the *Land Act*. As outlined in the aforementioned permits and licenses, notification is to occur: prior to initiation of an activity; within 30 days of completion of the activity; and, upon significant change to a construction activity. Therefore, the notification process applies to all open burning activities, as outlined in this smoke management plan. Indigenous groups will be notified by BCH Indigenous Affairs Department.

7.1.3 Other Stakeholders

All other stakeholders shall be notified by the contractor. Notification shall occur prior to 8:00 AM on the day of burn. Contractors must keep notification logs to document and track: day and time of notification, method of notification (email, phone, text, or a combination), results of notification (voicemail, read receipt, summary of conversation, etc.). Notification logs must be submitted by the contractor to BCH weekly.

Table 11. Geographical Units and Key Stakeholders for Notification. Contacts for key stakeholders are found in Section 7.3.

Stakeholders	Site C Reservoir			Transmission Line		Quarry Sites	
	Dam Site to Cache Creek	Cache Creek to Half-way River	Halfway River to Hudson's Hope	Site C Dam to Jackfish Road	Jackfish Road to Peace Canyon Dam	West Pine	Portage Mountain
RCMP	x	x	x	x	x		x
City of Fort St John	x			x			

Stakeholders	Site C Reservoir			Transmission Line		Quarry Sites	
	Dam Site to Cache Creek	Cache Creek to Half-way River	Halfway River to Hudson's Hope	Site C Dam to Jackfish Road	Jackfish Road to Peace Canyon Dam	West Pine	Portage Mountain
Fort St John Fire Department	x			x			
Charlie Lake Volunteer Fire Department	x						
Peace River Regional District	x	x	x	x	x		x
District of Taylor and Taylor Fire Department	x	x	x	x	x		
District of Hudson's Hope		x	x		x		x
Hudson's Hope Fire and Rescue Service		x	x		x		x
Chetwynd Fire Department					x	x	
District of Chetwynd					x	x	
BC Wildfire Service	x	x	x	x	x	x	x
Northern Health	x	x	x	x	x		x
MFLRNORD	x	x	x	x	x		x
Property owners	x	x	x	x	x	x	x

7.2 Wildfire Reporting

In accordance with the *Wildfire Act*, all wildfires shall be reported to 1.800.663.5555 or *5555 from a cellular phone.⁷⁵ There must be means on site to report a wildfire (cellular phone, satellite phone, or radio to someone with means to report).⁷⁶

7.3 Key Contacts

Table 12. Key contacts for notification, party responsible for notification, and primary method of notification.⁷⁷

Agency	Contact	Responsible for Notification	Primary Method for Notification
Ministry of Environment – Regional Contact	Earle Plain Head, Air Quality Section Monitoring, Assessment, and Stewardship Environmental Protection Ministry of Environment and Climate Change Strategy Office: 250-739-8253 Fax: 250-751-3103 Earle.Plain@gov.bc.ca 2080-A Labieux Road Nanaimo, BC V9T 6J9 Gail Roth Air Quality Meteorologist, Air Quality Section (Assessments) Monitoring, Assessment & Stewardship Ministry of Environment and Climate Change Strategy Office: 250-645-9358 Fax: 250-565-6629 Gail.Roth@gov.bc.ca Suite 325, 1011 4th Avenue, Prince George, BC V2L 3H9	Contractor	Email
Environment Canada Daily Ventilation Forecasts	https://www2.gov.bc.ca/gov/content/environment/air-land-water/air/air-pollution/smoke-burning/ventilation-index	N/A	N/A
RCMP Hudson Hope Detachment	Cpl. Rob Gardner email: robert.gardner@rcmp-grc.gc.ca Linda Cantlon Linda.cantlon@rcmp-grc.gc.ca	Contractor	Email

⁷⁵ 2 *Wildfire Act* S.B.C. 2004, c. 31

⁷⁶ 6(4) *Wildfire Regulation*, 38/2005

⁷⁷ Contacts are likely to change over the duration of the project. It is recommended to confirm and update, as necessary, prior to each burning season.

Agency	Contact	Responsible for Notification	Primary Method for Notification
RCMP Fort St John Detachment	S/Sgt. Scott Watson Email: Scott.Watson@rcmp-grc.gc.ca	Contractor	Email
City of Fort St John	Milo MacDonald, Chief Administrative Officer mmacdonald@fortstjohn.ca 250-787-8160	Contractor	Email
Fort St John Fire Department	Darrel Blades, Fire Chief dblades@fortstjohn.ca 250-785-4333	Contractor	Email
Peace River Regional District	prrd_dc@prrd.bc.ca 250-784-3200	Contractor	Email
District of Taylor and Taylor Fire Department	Steve Byford, LAFC, CD, Fire Chief Sbyford@districtoftaylor.com 250-789-3392 Kevin Holder, Deputy Fire Chief ecalla@districtoftaylor.com	Contractor	Email
District of Hudson's Hope	Mokles Rahman, Chief Administrative Officer cao@hudsonshope.ca 250-783-9901	Contractor	Email
Hudson's Hope Fire and Rescue Service	Brad Milton, Fire Chief brad@hudsonshope.ca 250-783-0542	Contractor	Email
Charlie Lake Volunteer Fire Department	Edward Albury, Fire Chief Edward.albury@prrd.bc.ca 250-785-1424	Contractor	Email
Chetwynd Fire Department ⁷⁸	Dan Golob dgolob@gochetwynd.com 250-788-2424	Contractor	Email
District of Chetwynd	Carol Newsom, Chief Administrative Officer CNewsom@gochetwynd.com 250-401-4104	Contractor	Email
BC Wildfire Service, Prince George Fire Centre	Doug Smith, Senior Wildfire Officer – Prevention Doug.j.smith@gov.bc.ca 778-693-2879 James Bergen, Fire Protection Officer james.bergen@gov.bc.ca 778-576-8898 250-785-6349	Contractor	Email
Northern Health	Resource.development@northernhealth.ca 250-263-6000 Seyoum Gebeyehu Environmental Health Officer, Health Protection and Disease Prevention Seyoum.gebeyehu@northernhealth.ca	Contractor	Email

⁷⁸ The Chetwynd Fire Department does not provide firefighting or rescue services for the West Pine quarry area. Highway rescue only is available.

Agency	Contact	Responsible for Notification	Primary Method for Notification
	Ali Moore Team Lead, Health Protection and Disease Prevention Ali.moore@northernhealth.ca		
MFLRNORD	Ken Dobb – Project Manager Ken.dobb@gov.bc.ca 250-795-4169	Contractor	Email
Property Owners	James Thomas, BC Hydro Senior Manager, Properties: James.Thomas@BCHydro.com 604-695-5288 Thomas Brent: Thomas.brent@bchydro.com Steven Burke: Steven.Burke@bchydro.com Will Mbaho, Communications Advisor: will.mbaho@bchydro.com 604-699-7281 Jimmy Yip: jimmy.yip@bchydro.com	BCH Public Relations Department	Bi-weekly Construction Report
First Nations		BCH Indigenous Affairs Department	TBD by BCH Indigenous Affairs Department

8.0 Qualified Professionals

This plan was revised in accordance with the BC Open Burning Smoke Control Regulation 405/19, enacted September 15, 2019, Waste Discharge Regulation, *Wildfire Act*, and Wildfire Regulation by the following qualified professional:

Tove Pashkowski Registered Professional Forester

This plan was originally prepared (June 2015) in accordance with the BC Open Burning Smoke Control Regulation (BC MOE 2012) and proposed updates to the regulation (BC MOE 2010), by the following qualified professionals:

William Golding Registered Professional Forester, Silvicon Services Inc.

Paul Veltmeyer Registered Professional Forester, BC Hydro.

9.0 Works Consulted

Alberta Wildfire. 2019. Brush Piles and Windrows Safe Burning Practices.

<https://open.alberta.ca/publications/9781460122389>. Accessed: 22 June, 2020.

BC Hydro 2013. Site C Clean Energy Project, Environmental Impact Statement.

British Columbia Ministry of Environment. “Open Burning Smoke Control Regulation.” Province of British Columbia, Province of British Columbia, 29 Mar. 2017,

<https://www2.gov.bc.ca/gov/content/environment/air-land-water/air/air-pollution/smoke-burning/regulations/openburningregulation> . Accessed: 25 October 2019.

BC Ministry of Environment. “Air Quality Objectives & Standards.” *Province of British Columbia*, Province of British Columbia, 10 Apr. 2017, <https://www2.gov.bc.ca/gov/content/environment/air-land-water/air/air-quality-management/regulatory-framework/objectives-standards>. Accessed August 22, 2017.

“B.C. Air Quality.” *Venting Index*, British Columbia Ministry of Environment,

<http://www.env.gov.bc.ca/epd/epdpa/venting/>. Accessed August 22, 2017

British Columbia Ministry of Forests, Lands, and Natural Resource Operations. 2014. Industrial and Resource Management Burning – A Guide to Category 3 and Resource Management Open Fires. http://www2.gov.bc.ca/assets/gov/public-safety-and-emergency-services/wildfire-status/fire-bans-and-restrictions/bcws_resourcegmt.pdf. Accessed August 4, 2017.

Bulkley Valley Smoke Management Plan Pilot, August 31, 2012.

<http://www.for.gov.bc.ca/dss/Smoke%20%20Zones/BV%20Smoke%20Management%20Plan%20Final%202012.pdf> Accessed: October 3, 2014

Bulkley Forest District Burn and Smoke Management Plan (BSMP), Sept 8, 2016.

<http://cleanairplan.ca/BOF2016/gq5SMP-BulkleySmokeManagementPlan2016-signed.pdf>

Accessed: August 3, 2017. *Continuing Care Act*. R.S.B.C. 1996, c. 70

Environmental Management Act [SBC 2003] Chapter 53.

Forest Planning and Practices Regulation B.C. Reg. 14/2004.

FP Innovations. n.d. *Woody Debris Management Strategies Info-Flip*.
<http://wildfire.fpinnovations.ca>. Accessed August 25, 2017.

Ministry of Environment and Climate Change Strategy. 2019. Factsheet Open Burning Smoke Control Regulation. https://www2.gov.bc.ca/assets/gov/environment/air-land-water/air/factsheets/obscr_general_factsheet.pdf. Accessed June 24, 2020.

Open Burning Smoke Control Regulation, BC Reg. 405/19

Waste Discharge Regulation, BC Reg. 154/2019

Wildfire Act. S.B.C. 2004, c. 31

Wildfire Regulation, BC Reg. 38/2005

Wildfire Regulation, BC Reg. 157/2020

Appendix B Air Quality Monitoring Program

Appendix B

Air Quality Monitoring Program

Site C Clean Energy Project

Revision 3: October 11, 2022

TABLE OF CONTENTS

Revision History	1
1.0 Background.....	2
2.0 Objectives	2
3.0 Scope.....	2
4.0 Monitoring Plan.....	2
4.1 Locations.....	2
4.2 Parameters.....	4
4.3 Duration	4
4.4 Frequency.....	4
5.0 Reporting	5
6.0 Sensitive Receptor Groups and Places of High Aboriginal Group Use	5
7.0 Qualified Environmental Professionals	7
8.0 References.....	7

Revision History

Version	Date	Comments
Rev 1	June 2017	
Rev 2	September 2020	Updates to sections 4.1 and 4.2
Rev 3	October 11, 2022	Updates to sections 4.0 and 7.0

1.0 Background

Potential changes in air quality due to construction of the project are described in the Site C Environmental Impact Statement (EIS) Section 11.11 Air Quality (BC Hydro, 2013a) and in EIS Volume 2, Appendix L Air Quality Technical Data Report (BC Hydro, 2013b). Dispersion modelling results indicate that provincial ambient air quality objectives for particulate matter may be exceeded in the absence of mitigation. However, mitigation measures have been proposed and are described Section 33.4.4 of the Project Environmental impact Statement (EIS) (BC Hydro, 2013c) that are expected to control emissions of fine particulate and dust so that ambient air quality objectives are not exceeded due to project construction. Maximum concentrations of nitrogen oxides, sulphur dioxide and carbon monoxide are predicted to be below relevant ambient air quality objectives due to Project construction, and no mitigation is required. The assessment of potential project effects on human health due to changes in ambient air quality are described in EIS Section 33 Human Health (BC Hydro, 2013c), which concluded that with implementation of proposed mitigation measures, no residual effects on human health are anticipated.

Measures to control emissions of fine particulate matter and dust, and to reduce potential effects on human health are included in the Construction Environmental Management Plan, Section 5.1 Air Quality Management (BC Hydro, 2014a). An air quality Environmental Protection Plan will be prepared for elements of construction that emit fine particulate and dust. Mitigation measures to be implemented will be described in those Environmental Protection Plans.

2.0 Objectives

The objectives of the Air Quality Monitoring Program are to:

- monitor ambient fine particulate concentrations, CO, NO₂ and SO₂; and
- develop a process for notification of sensitive populations and Aboriginal groups in the event of an exceedance of provincial ambient air quality objectives.

3.0 Scope

The scope of the Air Quality Monitoring Program includes continuous monitoring of ambient fine particulate matter during Project construction and the first two years of operations at locations that may be affected by construction activities as described in Section 4.

4.0 Monitoring Plan

4.1 Locations

Air quality monitoring stations operated by BC Hydro have been installed at the following locations (see Figure 1):

- 85th Avenue Industrial Lands

- Old Fort
- Attachie Flat upper terrace

In addition, BC Hydro will install air quality monitoring stations at the following locations (see Figure 1):

- Site C worker accommodation complex
- Hudson's Hope berm site

BC Ministry of Environment operates an air quality monitoring station at the Key Learning Centre in Fort St. John.

At the Hudson's Hope berm site, mobile air quality monitoring will be undertaken in response to public complaints, subject to staff safety considerations, access permission being granted by the property owner, construction being active, and weather conditions (e.g. no monitoring during periods of precipitation, and in consideration of operational limits of the instrument) to ensure a representative sample.

If a complaint is related to the haul truck route, measurements will be taken at or near the complainant's location for a period of 2 hours, with visual observations of project-related road traffic and dust-generating material deposited by Project vehicles to correlate to spot measurements of particulate matter, for comparison to general road dust generated by other (non-Project) users. In the event that project-related traffic is associated with elevated particulate matter readings above the general road traffic and exceeding the BC ambient air quality objective during the monitoring period (2 hour averaged value rather than 24 hour averaged value, as a conservative approach), implementation of mitigations as per the Construction Environmental Management Plan section 4.1 [Air Quality Management] by the contractors will be verified by BC Hydro, including a requirement to cover all loads while on public roads. A subsequent round of spot monitoring will occur to verify effectiveness of these mitigations, followed by the implementation of the additional mitigation measure of application of dust suppressant and/or street sweeping) in coordination with the road owner (District of Hudson's Hope or Ministry of Transportation and Infrastructure) if the above-noted criteria continue to be exceeded.

If a complaint is related to the shoreline protection work area, measurements will be taken for a period of 12 hours (the limit of the device's internal battery) or as long as the power source allows (to a maximum of 48 hours where a fixed power source is made available by a complainant). Data will be compared to BC ambient air quality objectives (where 24 hours of data or more is collected), and data collected during the same period at the existing fixed ambient air quality station. Monitoring will begin at the closest complainant to the active construction activity, and work radially outward if 1) there is an exceedance of the BC ambient air quality objective that could be attributed to the Project (where sufficient duration of data has been collected to assess, and in consideration of wind measurements during the monitoring period), or 2) where there is a strong disagreement between the mobile monitoring data and the data collected during the same period at the fixed air quality monitoring station on Dudley Drive. In the event that project-related construction activity is associated with elevated particulate matter readings above the BC ambient air quality objectives, implementation of mitigations as per the Construction Environmental Management Plan section 4.1 [Air Quality Management] will be required of the contractors by BC Hydro, with implementation of the additional mitigation measure of spraying the rock pile at the handling area with water throughout the day as required when it is visibly releasing dust, as the ambient temperature safely allows.

4.2 Parameters

Two fractions of fine particulate matter will be measured at all of the BC Hydro operated stations – less than 10 microns (PM₁₀) and less than 2.5 microns (PM_{2.5}).

NO₂ and SO₂ will be measured at the Site C worker accommodation complex and at Hudson's Hope berm site.

Mobile monitoring at the Hudson's Hope berm site will measure PM₁₀ concentrations.

PM_{2.5}, PM₁₀, O₃, NO₂, NO, NO_x and SO₂ are monitored at the Key Learning Centre station; meteorological parameters to be added in 2020.

4.3 Duration

Monitoring at the following locations began in 2014 or earlier and will continue throughout construction and for the first two years of operations:

- 85th Avenue Industrial Lands
- Old Fort
- Attachie Flat upper terrace

Monitoring at the Site C worker accommodation complex will begin in 2015 and continue until the end of the first two years of operations. Continuous monitoring at the Hudson's Hope berm site will begin prior to the start of berm construction and continue until the end of the first two years of operations.

Mobile monitoring associated with the Hudson's Hope shoreline protection construction will be for a period of 2 hours (if associated with a complaint along the haul route), or for a period of 12 hours or as long as the power source allows (up to a maximum of 48 hours) if associated with the shoreline protection work area.

4.4 Frequency

Monitoring at all fixed locations will be continuous.

Mobile monitoring (spot measurements) associated with the Hudson's Hope shoreline protection works will be initiated by public complaints.

5.0 Reporting

BC Hydro will develop a procedure for notifying Northern Health and the BC Ministry of Environment in case of exceedance of provincial ambient air quality objectives. Northern Health and the BC Ministry of Environment will be responsible for notifying sensitive populations and Aboriginal groups of any exceedance.

BC Hydro will assess the monitoring data during Project construction and determine if any exceedances of provincial ambient air quality objectives occurred due to Project activities.

An annual summary report will be submitted to BCEAO, BCMOE, BCMFLNRO, CEAA, City of Fort St. John, District of Hudson's Hope, District of Taylor and PRRD. First Nations will be notified in accordance with the Project's First Nations Communications Plan.

6.0 Sensitive Receptor Groups and Places of High Aboriginal Group Use

Sensitive receptors were identified in EIS Volume 2, Appendix L, Air Quality Technical Data Report. This list was updated in Undertaking 81 during the Joint Review Panel hearing for the Project (BC Hydro, 2014b).

The identified sensitive receptors are:

SCHOOLS

- Aboriginal Education Center
- Alwin Holland
- Baldonnel Elementary
- Bert Ambrose Elementary
- Bert Bowes Middle School
- Board Office
- Charlie Lake Elementary
- Christian Life School
- CM Finch Elementary
- Dr. Kearney Middle School
- Duncan Cran Elementary
- École Central Elementary
- Facilities & Transportation
- Key Learning Centre
- North Peace Secondary
- Energetic Learning Campus
- Northern BC Distance Education
- Open Learning
- Robert Ogilvie Elementary
- Student Support Services
- Taylor Elementary
- Technology Services

HEALTH CARE FACILITIES

- Fort St. John Health Unit
- Fort St. John Hospital
- Fort St. John Medical Clinic
- Fort St. John Pharmacy and Wellness Centre
- The Taylor Medical Clinic
- ABC Medical Clinic
- North Peace Medical Clinic

SENIOR CARE FACILITIES

- Heritage Manor
- Peace Lutheran Apt. #1
- Peace Lutheran Apt. #2
- The Sunset Home
- North Peace Care Centre
- Abbeyfield Houses of Fort St. John
- New Senior Housing
- Peace Villa

PLACES OF HIGH ABORIGINAL GROUP USE

Aboriginal groups that have informed BC Hydro of their use of places of high Aboriginal group use will be notified in the event of an exceedance of provincial ambient air quality objectives in accordance with the procedure developed pursuant to Section 5 Reporting of this Air Quality Monitoring Program.

In order to identify and confirm important sites (e.g. burial, cultural, ceremonial, habitation, medicinal and food plants), BC Hydro started a ground-truthing initiative in 2014.

The purpose of the ground-truthing initiative is to engage with Aboriginal land users, including registered trapline holders, to verify and accurately site land use information, and to identify concerns related to specific features and or sites that may be affected by the proposed Project. In particular, BC Hydro is seeking to verify features such as plant sites (specifically medicinal and food plants), the location of burial sites, and the location of habitation sites, including when and how they are used by Aboriginal groups.

During ground truthing, the locations of features and sites are recorded by digital video, photography, notes and GPS. Following completion of field work associated with ground truthing, BC Hydro will prepare a report, which will be shared with land users for their review and comment. BC Hydro will seek to avoid or mitigate the potential health effects from exceedances of provincial ambient air quality objectives on Aboriginal groups who use the specific sites which have been identified in the ground-truthing exercise.

BC Hydro has initiated ground-truthing with six registered trapline owners from the Sauteau First Nations. An invitation to other Aboriginal groups to engage in ground-truthing was sent in September 2014, with an initial focus on the dam site area. BC Hydro anticipates that most ground truthing work will be completed during the first year of construction but may continue as construction progresses.

7.0 Qualified Environmental Professionals

The Air Quality Monitoring Program was prepared by the following Qualified Environmental Professional:

Revision 1 was prepared by Al Strang, P. Eng., BC Hydro.

Revision 3 updates were made by Molly Brewis, P.Chem, PMP, BC Hydro with review by David Chadder, Hon. B.Sc., QEP, RWDI.

8.0 References

BC Hydro, 2013a. Site C Clean Energy Project Environmental Impact Statement, Volume 2, Section 11.11 Environmental Background - Air Quality

BC Hydro, 2013b. Site C Clean Energy Project Environmental Impact Statement, Volume 2, Appendix L Air Quality Technical Data Report

BC Hydro, 2013c. Site C Clean Energy Project Environmental Impact Statement Section 33 Human Health

BC Hydro, 2014a. Site C Clean Energy Project Construction Environmental Management Plan

BC Hydro, 2014b. Site C Clean Energy Project Joint Review Panel Hearing, Undertaking No. 81

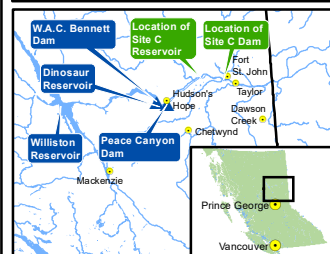
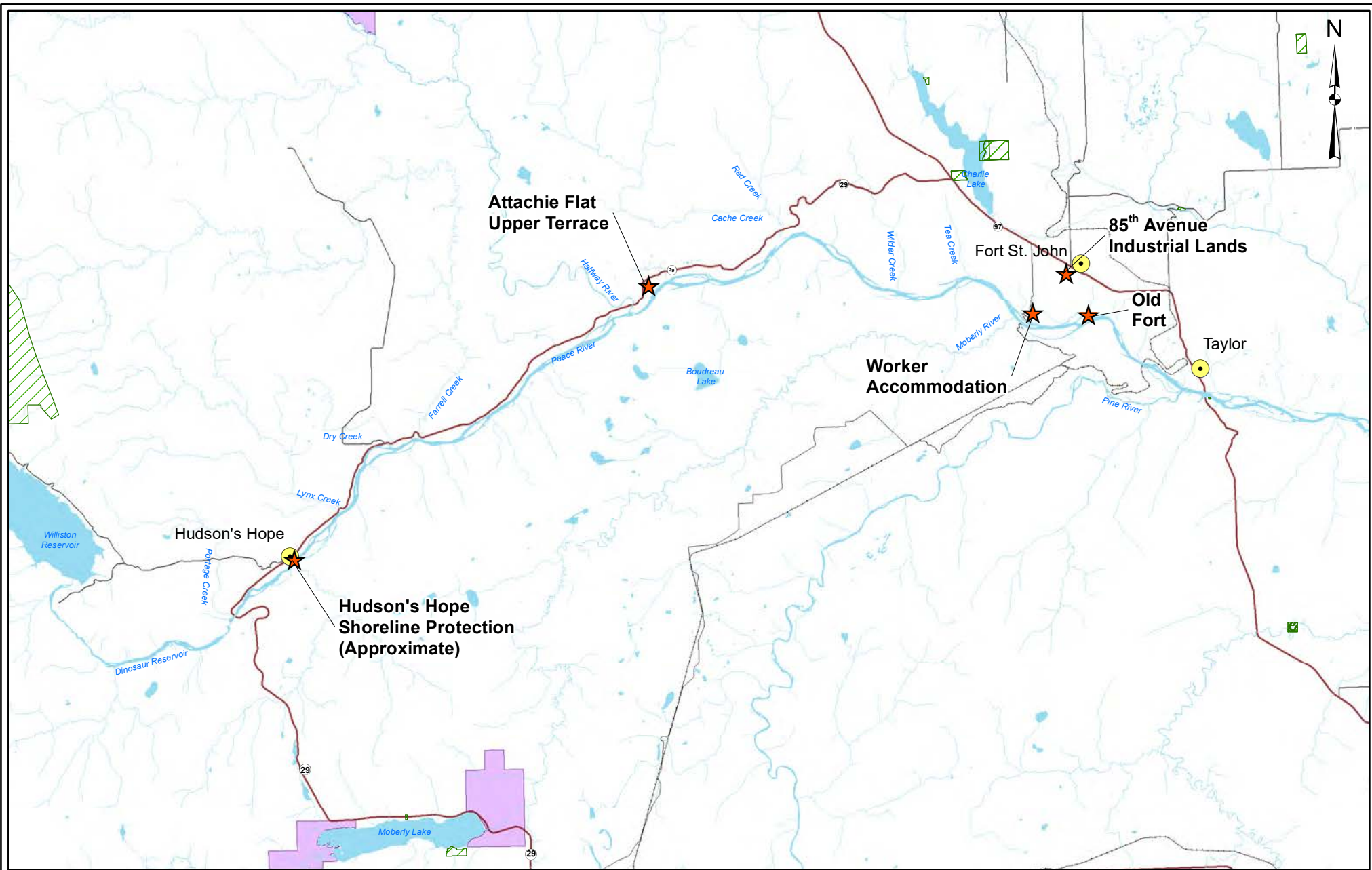

Map Notes:
 1. Datum: NAD83
 2. Projection: UTM Zone 10N
 3. Base Data: Province of B.C.

Legend

- Air Quality Monitoring Station
- City/District Municipality
- Protected Areas, Provincial Parks, Regional Parks, and Ecological Reserves
- Existing Road
- Indian Reserve
- Existing Highway
- Existing Railway

1:430,000



Air Quality Monitoring Stations Operating During Project Construction

DATE	Mar 6, 2018	1016-C14-A7719	R 1
------	-------------	----------------	-----

X:\AC\GIS\Projects\Monitoring\AirQuality\Monitor\Stations - 1016_C14_A7719.mxd

Appendix C Construction Communications Plan

Appendix C

Construction Communication Plan

Site C Clean Energy Project

Revision 1: June 2015

TABLE OF CONTENTS

Revision History	2
1.0 Background	3
1.1 The Site C Clean Energy Project	3
1.2 Project Benefits	3
1.3 Environmental Assessment Process	3
1.4 Environmental Assessment Findings	4
1.5 Environmental Assessment Conclusion	4
1.6 Development of Mitigation, Management and Monitoring Plans	5
2.0 Construction Communications Plan	5
2.1 Objective and Scope	5
2.2 Consultation	6
3.0 Statement of Objectives	8
3.1 Audiences and Stakeholders	9
3.2 Information and Notification Tools	9
4.0 Audiences	10
5.0 Key Activities and Tools	11
5.1 Communications Activities	11
5.2 Community Relations	12

1.0 Background

1.1 The Site C Clean Energy Project

The Site C Clean Energy Project (the Project) will be the third dam and generating station on the Peace River in northeast B.C. The Project will provide 1,100 megawatts of capacity and about 5,100 gigawatt hours of energy each year to the province's integrated electricity system. The Project will be a source of clean, reliable and cost-effective electricity for BC Hydro's customers for more than 100 years.

The key components of the Project are:

- an earthfill dam, approximately 1,050 metres long and 60 metres high above the riverbed;
- an 83 kilometre long reservoir that will be, on average, two to three times the width of the current river;
- a generating station with six 183 MW generating units;
- two new 500 kilovolt AC transmission lines that will connect the Project facilities to the Peace Canyon Substation, along an existing right-of-way;
- realignment of six segments of Highway 29 over a total distance of approximately 30 kilometers; and
- construction of a berm at Hudson's Hope.

The Project will also include the construction of temporary access roads, a temporary bridge across the Peace River, and worker accommodation at the dam site.

1.2 Project Benefits

The Project will provide important benefits to British Columbia and Canada. It will serve the public interest by delivering long term, reliable electricity to meet growing demand; contribute to employment, economic development, ratepayer, taxpayer and community benefits; meet the need for electricity with lower GHG impact than other resource options; contribute to sustainability by optimizing the use of existing hydroelectric facilities, delivering approximately 35 per cent of the energy produced at the W.A.C. Bennett Dam, with only five per cent of the reservoir area; and include an honourable process of engagement with First Nations and the potential for accommodation of their interests.

1.3 Environmental Assessment Process

The environmental assessment of the Project has been carried out in accordance with the Canadian Environmental Assessment Act, 2012 (CEAA 2012), the BC Environmental Assessment Act (BCEAA), and the Federal-Provincial Agreement to Conduct a Cooperative Environmental Assessment, Including the Establishment of a Joint Review Panel of the Site C Clean Energy Project. The assessment considered the environmental, economic, social, heritage and health effects and benefits of the Project, and included the engagement of Aboriginal groups, the public, all levels of government, and other stakeholders in the assessment process.

Detailed findings of the environmental assessment are documented in the Site C Clean Energy Project Environmental Impact Statement (EIS), which was completed in accordance with the Environmental Impact Statement Guidelines (EIS Guidelines) issued by the Minister of Environment of Canada and the Executive Director of the Environmental Assessment Office of British Columbia. The EIS was submitted to regulatory agencies in January 2013, and amended in August 2013 following a 60 day public comment period on the assessment, including open house sessions in Fort St. John, Hudson's Hope, Dawson Creek, Chetwynd, town of Peace River (Alberta) and Prince George.

In August 2013, an independent Joint Review Panel (JRP) commenced its evaluation of the EIS, and in December 2013 and January 2014 undertook five weeks of public hearings on the Project in 11 communities in the Peace region, including six Aboriginal communities. In May 2014, the JRP provided the provincial and federal governments with a report summarizing the Panel's rationale, conclusions and recommendations relating to the environmental assessment of the Project. On completion of the JRP stage of the environmental assessment, the CEA Agency and BCEAO consulted with Aboriginal groups on the JRP report, and finalized key documents of the environmental assessment for inclusion in a Referral Package for the Provincial Ministers of Environment and Forests, Lands and Natural Resource Operations.

Construction of the Project is also subject to regulatory permits and authorizations, and other approvals. In addition, the Crown has a duty to consult and, where appropriate, accommodate Aboriginal groups.

1.4 Environmental Assessment Findings

The environmental assessment of the Project focused on 22 valued components (VCs), or aspects of the biophysical and human setting that are considered important by Aboriginal groups, the public, the scientific community, and government agencies. In the EIS, valued components were categorized under five pillars: environmental, economic, social, heritage and health. For each VC, the assessment of the potential effects of the Project components and activities during construction and operations was based on a comparison of the biophysical and human environments between the predicted future conditions with the Project, and the predicted future conditions without the Project.

Potential adverse effects on each VC are described in the EIS along with technically and economically feasible mitigation measures, their potential effectiveness, as well as specific follow-up and related commitments for implementation. If a residual effect was found on a VC, the effect was evaluated for significance. Residual effects were categorized using criteria related to direction, magnitude, geographic extent, context, level of confidence and probability, in accordance with the EIS Guidelines.

The assessment found that the effects of the Project will largely be mitigated through careful, comprehensive mitigation programs and ongoing monitoring during construction and operations. The EIS indicates that the Project is unlikely to result in a significant adverse effect for most of the valued components. However, a determination of a significant effect of the Project was found on four VCs: Fish and Fish Habitat, Wildlife Resources, Vegetation and Ecological Communities, and Current Use of Lands and Resources for Traditional Purposes.

1.5 Environmental Assessment Conclusion

On October 14, 2014, the Provincial Ministers of Environment and of Forests, Lands and Natural Resource Operation decided that the Project is in the public interest and that the

benefits provided by the Project outweigh the risks of significant adverse environmental, social and heritage effects (<http://www.newsroom.gov.bc.ca/2014/10/site-c-project-granted-environmental-assessment-approval.html>). The Ministers have issued an Environmental Assessment Certificate (EAC) setting conditions under which the Project can proceed.

Further, on November 25, 2014, The Minister of Environment of Canada issued a Decision Statement confirming that, while the Project has the potential to result in some significant adverse effects, the Federal Cabinet has concluded that those effects are justified in the circumstances. The Decision Statement sets out the conditions under which the Project can proceed.

1.6 Development of Mitigation, Management and Monitoring Plans

Mitigation, management and monitoring plans for the Project have been developed taking into account the measures proposed in the EIS, information received during the Joint Review Panel hearing process, and the Report of the Joint Review Panel on the Project. Those plans are consistent with, and meet requirements set out in, the conditions of the Environmental Assessment Certificate and of the Decision Statement issued on October 14, 2014 and November 25, 2014 respectively.

In addition, in accordance with environmental best practices (Condition 3.1), these plans were informed by the best available information and knowledge, based on validated methods and models, undertaken by qualified individuals and apply the best available economically and technologically feasible mitigation strategies. These plans contain provisions for review and update as new information on the effects of the Project and on the efficacy of the mitigation measures become available.

2.0 Construction Communications Plan

2.1 Objective and Scope

This Plan has been developed in accordance with the following Conditions 39, 43 and 72 of the Environmental Assessment Certificate (EAC).

EAC 39, 43, 72

Condition Number	Condition	Plan Reference
EAC Condition 39	The EAC Holder must provide information to the Province of Alberta, during construction and operations, to assist in their communications with anglers in Alberta regarding changes in downstream fishing opportunities due to construction activities and longer-term changes in fish community composition.	Section 3.0 Statement of Objectives Section 4.0 Audiences
EAC Condition 43	The EAC Holder must develop an Emergency Services Plan that includes at least the following to describe how the EAC Holder will implement measures to: Communicate Project emergency management plans to all emergency service providers, and	Section 4.0 Audiences

Condition Number	Condition	Plan Reference
	provide updates as plans are amended	
EAC Condition 72	The EAC Holder must manage effective communications for the Project by implementing measures in communication plans and a business participation plan. The following communication and participation plans are to be developed and implemented: <ul style="list-style-type: none"> • Business Participation Plan; • Construction Communication Plan; and • First Nations Communication Plan. 	
	Each plan in addition to plan specific conditions identified in this document will include:	
	<ul style="list-style-type: none"> • Clear Statement of Objectives; 	Section 3.0 Statement of Objectives
	<ul style="list-style-type: none"> • Audiences; 	Section 3.1 Audiences and Stakeholders; 4.0 Audiences
	<ul style="list-style-type: none"> • Key activities and tools; and Annual summary reporting. 	Section 3.2 Information and Notification Tools; Section 5.0 Key Activities and Tools

2.2 Consultation

Many of the conditions require BC Hydro to consult or collaborate with certain government agencies and Aboriginal groups in respect of measures and plans required by the conditions.

BC Hydro began consultation on the Project in late 2007, before any decision to advance the Project to an environmental assessment. BC Hydro's consultation with the public, stakeholders, regional and local governments, regulatory agencies, and Aboriginal groups is described in EIS Section 9, Information Distribution and Consultation.

Additional information on the consultation process and a summary of issues and concerns raised during consultation are provided in:

- Volume 1 Appendix G, Public Information Distribution and Consulting Supporting Documentation
- Volume 1 Appendix H, Aboriginal Information Distribution and Consultation Supporting Documentation
- Volume 1 Appendix I, Government Agency Information Distribution and Consultation Supporting Documentation
- Volume 5, Appendix A01 to A29, Parts 2 and 2A, Aboriginal Consultation Summaries
- Technical Memo: Aboriginal Consultation

Draft versions of a number of the mitigation, management and monitoring plans required by the conditions were submitted to applicable government agencies and Aboriginal groups for comment on October 17, 2014.

Comments on these draft plans were received from various government agencies and Aboriginal groups during November and December 2014, and were considered in the revisions to these plans. BC Hydro's consideration of these comments is provided in the consideration tracking tables that accompany each plan.

On December 15, 2014, Treaty 8 Tribal Association (T8TA), on behalf of West Moberly, Saulteau and Prophet River First Nations, submitted to BC Hydro a letter in response to BC Hydro's request for comment on the Plans sent on October 17, 2014. The letter included several appendices, including the Joint Review Panel (JRP) Report and transcripts from the JRP hearings in December 2013 and January 2014. BC Hydro responded to the three First Nations on January 21, 2015 noting that the October 17 2014 request for comments on the plans was to provide an opportunity to the First Nations to submit to BC Hydro any information they wanted to provide in relation to the Plans. BC Hydro advised that it was aware of the information referred to in T8TA's letter when the plans were prepared, and advised that it was preparing a table setting out where any mitigation measures identified by representatives of the three First Nations during the hearings are considered in the draft plans and would provide that to the First Nations once complete. Accordingly BC Hydro's responses to those mitigation measures identified by the representatives of the three First Nations during the JRP hearings were provided to the EAO in a separate table by letter dated May 19, 2015. Aside from the December 15, 2014 letter, BC Hydro has not received further comments from these First Nations. A letter of understanding dated April 30, 2015 respecting provision of capacity funding to support review of the plans was entered into by BC Hydro and Saulteau First Nations (on behalf of Saulteau, West Moberly and Prophet River First Nations).

New draft plans (i.e., Housing Plan and Housing Monitoring and Follow-Up Program, and the quarry/pit development plans) were provided to the entities identified in the EAC conditions on April 7, 2015. The Vegetation and Wildlife Mitigation and Monitoring Plan was revised based on comments received on the October 17, 2014 version and based on discussions with Environment Canada and the BC Ministry of Environment, and was re-submitted to applicable entities on April 7, 2015.

Comments on the revised plans were requested by May 11, 2015 to allow for review, consideration of comments and finalization of the plans 30 days prior to the commencement of construction.

Comments were received by this requested date from:

- Fort Nelson First Nation
- Ministry of Forests, Lands and Natural Resource Operations (FLNRO), and
- Métis Nation British Columbia.

The Peace River Regional District submitted their comments on the plan on May 14, 2015. FLNRO submitted additional comments on May 15, 2015, including comments from the BC Ministry of Environment.

BC Hydro considered the comments provided and prepared final plans. On May 19, 2015, BC Hydro submitted the following mitigation, management and monitoring plans to the BC Environmental Assessment Office (BC EAO) for review:

- Construction Environmental Management Plan
- Construction Safety Management Plan
- Fisheries and Aquatic Habitat Management Plan
- Vegetation and Wildlife Mitigation and Monitoring Plan
- Vegetation Clearing and Debris Management Plan
- Aboriginal Plant Use Mitigation Plan
- Aboriginal Training and Inclusion Plan
- Business Participation Plan
- Emergency Services Plan
- Healthcare Services Plan
- Labour and Training Plan
- Cultural Resources Mitigation Plan
- Heritage Resources Management Plan
- Housing Plan and Housing Monitoring and Follow-Up Program
- Wuthrich Quarry Development Plan
- West Pine Quarry Development Plan; and
- Del Rio Pit Development Plan.

The CEA Agency and Environment Canada submitted comments on the revised plan on May 22, 2015. These comments were considered and the final plans were revised accordingly and submitted on June 5, 2015 to the entities identified in the EAC conditions.

3.0 Statement of Objectives

BC Hydro will provide regular updates to the public about construction activities, mitigation program activities, and about business and job opportunities, and will provide means for the public to ask questions, and to provide comments and feedback during construction as per Condition 72 of the EAC. Communications will be initiated prior to the start of construction activities.

BC Hydro will provide information about construction activities, schedules and mitigation and monitoring programs.

As described in Section 9.1.4 of the Environmental Impact Statement (EIS), objectives of this plan are to:

- Continue to facilitate regular community and stakeholder communications regarding the Project
- Maintain cooperative relationships with regional and local government and work with them to manage construction information and issues
- Maintain strong relationships with the business community through the Business Liaison Program

The scope of the construction phase communication program includes:

- Regular, two-way community and stakeholder communications regarding the Project, including engagement through the Community Liaison Committees
- Timely construction information including but not limited to air quality monitoring results, burning plans, burning summaries, and blasting schedules.
- Engagement with regional and local governments to manage construction issues
- Media updates on construction and traffic information and key project milestones
- Continuation of the Project's Business Liaison Program

BC Hydro will provide regular updates to the public about construction activities, and about business and job opportunities, and will provide means for the public to ask questions, and to provide comments and feedback during construction.

In addition, as per EAC condition 39, BC Hydro provide ongoing information to the Province of Alberta during construction and operations to assist in their communications with anglers in Alberta regarding changes in downstream fishing opportunities due to construction activities and longer-term changes in fish community composition.

Prior to the start of construction, BC Hydro will initiate construction communications to raise awareness and understanding of Site C construction activities, and how to find out information about construction activities.

Each year, BC Hydro will provide an annual summary report about the construction communications program related to meeting program objectives. This report will be posted on the project website.

3.1 Audiences and Stakeholders

A preliminary list is included below.

- Aboriginal Groups
- Public
- Property owners/leaseholders
- Local and regional governments
- Business and industry potentially affected by construction
- Potential workers
- Potential contractors
- Regional and local stakeholder groups
- News media

3.2 Information and Notification Tools

A variety of construction information and notification tools will be used, including

Communications Activities:

- Project Website (sitecproject.com)
- Advertising
- Construction Information Telephone Line

- Construction Bulletins
- Email Updates
- Mailings
- Information Materials
- Media Relations
- Social Media
- Signage

Community Relations:

- Community Consultation Offices
- Neighbourhood Meetings
- Property Owner and Tenure Holder Liaison
- Open Houses
- Business Participation Program
- Council Presentations
- Community Liaison Committees

4.0 Audiences

BC Hydro's construction information and notification program is intended to reach the public, Aboriginal groups (see also the Aboriginal Communications Plan), residents, local governments and other stakeholder groups in the Peace region. A preliminary list is included below.

- Aboriginal Groups
 - Blueberry River First Nations
 - Dene Tha' First Nation
 - Doig River First Nation
 - Duncans First Nation
 - Fort Nelson First Nation
 - Halfway River First Nation
 - Horse Lake First Nation
 - Kelly Lake Métis Settlement Society
 - McLeod Lake Indian Band
 - Métis Nation British Columbia
 - Prophet River First Nation
 - Saulteau First Nations
 - West Moberly First Nations
- General Public

- Residents of properties in the vicinity of the Project Activity Zone
- Local and regional governments
 - City of Fort St. John
 - City of Dawson Creek
 - District of Chetwynd
 - District of Hudson's Hope
 - District of Taylor
 - Peace River Regional District
 - Town of Peace River, Alberta
- Province of BC
- Province of Alberta
- Government of Canada
- Business and industry in the vicinity of the Project Activity Zone
- Potential workers
- Potential contractors
- Regional and local stakeholder groups
- Emergency Service Providers
- News media

5.0 Key Activities and Tools

A variety of construction information and notification tools will be used, including advertising, email alerts, mailings, website information and extensive media and community outreach to ensure a broad distribution of construction-related information. In addition, information and notification will be provided through ongoing community relations, as well as Aboriginal engagement and consultation.

5.1 Communications Activities

- **Project Website (sitecproject.com):** The project website will be updated to include regular information about site preparation, early works and construction activities, as well as all construction-related information. This information is expected to include an eight-year construction schedule summary, a 1-month look-ahead schedule for construction, and background information on construction. In addition, the website will include relevant project maps, a construction photo gallery, and information for businesses and workers.
- **Advertising:** BC Hydro will advertise in local and regional media outlets to inform and notify key audiences about construction-related activities, prior to the start of work, as appropriate.
- **Construction Information Telephone Line:** A phone line will be set up, which the public can call to receive the most up-to-date information about construction activities, or to provide feedback or comments about the project.
- **Construction Bulletins:** Site C construction bulletins will be developed, posted on the project website, delivered to key news outlets and emailed to web subscribers. The

construction bulletins will provide advance notification of construction activities, its potential impacts and duration.

- **Mailings:** BC Hydro will send notices by mail prior to the commencement of any work in close proximity of homes and/or businesses, as appropriate.
- **Information Materials:** BC Hydro will develop public information materials on the construction phase, including an updated brochure, fact sheets and backgrounders.
- **Media Relations:** BC Hydro will inform local media outlets of key construction activities as part of its information and notification program.
- **Social Media:** BC Hydro will use social media networks, such as Twitter, to inform and notify key audiences about construction activities.
- **Signage:** Appropriate signage will be placed at construction sites for the project, as well as on public roads and highways where construction activities are taking place.

5.2 Community Relations

- **Community Consultation Offices:** The Project's community consultation offices are located in Fort St. John and Hudson's Hope. The offices will continue to be staffed throughout the construction phase to provide a location where the public can get information about the Project, ask questions and submit feedback.
- **Neighbourhood Meetings:** As appropriate, BC Hydro will meet with property owners in the vicinity of construction activity, prior to the work commencing, to provide information about schedule, work hours and activities. The meetings will also provide an opportunity to answer questions and hear feedback or concerns.
- **Open Houses:** BC Hydro will hold public information meetings to provide information about Site C construction activities, including schedule, impacts and duration of work. The meetings will also provide an opportunity for BC Hydro to answer questions, gather feedback and hear about concerns.
- **Council Presentations:** Project team representatives will continue to provide updates to local and regional government councils on major Project milestones and construction-related activities.
- **Community Liaison Committees:** During the construction phase, BC Hydro will establish Community Liaison Committees. The Committees will provide an opportunity to BC Hydro to keep communities informed of project activities, as well as to answer questions and hear about concerns.

Appendix D Aboriginal Group Communication Plan

Aboriginal Group Communication Plan

Site C Clean Energy Project

Revision 2: June 24, 2015

Table of Contents

Revision History	2
1.0 Background	3
1.1 The Site C Clean Energy Project	3
1.2 Project Benefits	3
1.3 Environmental Assessment Process	3
1.4 Environmental Assessment Findings	4
1.5 Environmental Assessment Conclusion	5
1.6 Development of Mitigation, Management and Monitoring Plans	5
2.0 Aboriginal Group Communication Plan	5
2.1 Objective and Scope	5
2.2 Consultation	7
3.0 Scope of Plan	9
4.0 Audiences	9
5.0 Key Activities and Tools	10
6.0 Plan Reporting Requirements	11

Revision History

Version	Date	Comments
Draft	10-17-2014	Draft
Draft	02-26-2015	Draft
Rev 0	05-19-2015	Final Plan
Rev 1	06-05-2015	Final Plan, Revision 1
Rev 2	06-24-2015	Updated Key Activities and Tools with additional engagement processes

1.0 Background

1.1 The Site C Clean Energy Project

The Site C Clean Energy Project (the Project) will be the third dam and generating station on the Peace River in northeast B.C. The Project will provide 1,100 megawatts of capacity and about 5,100 gigawatt hours of energy each year to the province's integrated electricity system. The Project will be a source of clean, reliable and cost-effective electricity for BC Hydro's customers for more than 100 years.

The key components of the Project are:

- an earthfill dam, approximately 1,050 metres long and 60 metres high above the riverbed;
- an 83 kilometre long reservoir that will be, on average, two to three times the width of the current river;
- a generating station with six 183 MW generating units;
- two new 500 kilovolt AC transmission lines that will connect the Project facilities to the Peace Canyon Substation, along an existing right-of-way;
- realignment of six segments of Highway 29 over a total distance of approximately 30 kilometers; and
- construction of a berm at Hudson's Hope.

The Project will also include the construction of temporary access roads, a temporary bridge across the Peace River, and worker accommodation at the dam site.

1.2 Project Benefits

The Project will provide important benefits to British Columbia and Canada. It will serve the public interest by delivering long term, reliable electricity to meet growing demand; contribute to employment, economic development, ratepayer, taxpayer and community benefits; meet the need for electricity with lower GHG impact than other resource options; contribute to sustainability by optimizing the use of existing hydroelectric facilities, delivering approximately 35 per cent of the energy produced at the W.A.C. Bennett Dam, with only five per cent of the reservoir area; and include an honourable process of engagement with First Nations and the potential for accommodation of their interests.

1.3 Environmental Assessment Process

The environmental assessment of the Project has been carried out in accordance with the *Canadian Environmental Assessment Act, 2012* (CEAA 2012), the *BC Environmental Assessment Act* (BCEAA), and the *Federal-Provincial Agreement to Conduct a Cooperative Environmental Assessment, Including the Establishment of a Joint Review Panel of the Site C Clean Energy Project*. The assessment considered the environmental, economic, social, heritage and health effects and benefits of the Project, and included the engagement of Aboriginal groups, the public, all levels of government, and other stakeholders in the assessment process.

Detailed findings of the environmental assessment are documented in the Site C Clean Energy Project Environmental Impact Statement (EIS), which was completed in accordance with the Environmental Impact Statement Guidelines (EIS Guidelines) issued by the Minister of Environment of Canada and the Executive Director of the Environmental Assessment Office of British Columbia. The EIS was submitted to regulatory agencies in January 2013, and amended in August 2013 following a 60 day public comment period on the assessment, including open house sessions in Fort St. John, Hudson's Hope, Dawson Creek, Chetwynd, town of Peace River (Alberta) and Prince George.

In August 2013, an independent Joint Review Panel (JRP) commenced its evaluation of the EIS, and in December 2013 and January 2014 undertook five weeks of public hearings on the Project in 11 communities in the Peace region, including six Aboriginal communities. In May 2014, the JRP provided the provincial and federal governments with a report summarizing the Panel's rationale, conclusions and recommendations relating to the environmental assessment of the Project. On completion of the JRP stage of the environmental assessment, the CEA Agency and BCEAO consulted with Aboriginal groups on the JRP report, and finalized key documents of the environmental assessment for inclusion in a Referral Package for the Provincial Ministers of Environment and Forests, Lands and Natural Resource Operations.

Construction of the Project is also subject to regulatory permits and authorizations, and other approvals. In addition, the Crown has a duty to consult and, where appropriate, accommodate Aboriginal groups.

1.4 Environmental Assessment Findings

The environmental assessment of the Project focused on 22 valued components (VCs), or aspects of the biophysical and human setting that are considered important by Aboriginal groups, the public, the scientific community, and government agencies. In the EIS, valued components were categorized under five pillars: environmental, economic, social, heritage and health. For each VC, the assessment of the potential effects of the Project components and activities during construction and operations was based on a comparison of the biophysical and human environments between the predicted future conditions with the Project, and the predicted future conditions without the Project.

Potential adverse effects on each VC are described in the EIS along with technically and economically feasible mitigation measures, their potential effectiveness, as well as specific follow-up and related commitments for implementation. If a residual effect was found on a VC, the effect was evaluated for significance. Residual effects were categorized using criteria related to direction, magnitude, geographic extent, context, level of confidence and probability, in accordance with the EIS Guidelines.

The assessment found that the effects of the Project will largely be mitigated through careful, comprehensive mitigation programs and ongoing monitoring during construction and operations. The EIS indicates that the Project is unlikely to result in a significant adverse effect for most of the valued components. However, a determination of a significant effect of the Project was found on four VCs: Fish and Fish Habitat, Wildlife Resources, Vegetation and Ecological Communities, and Current Use of Lands and Resources for Traditional Purposes.

1.5 Environmental Assessment Conclusion

On October 14, 2014, the Provincial Ministers of Environment and of Forests, Lands and Natural Resource Operation decided that the Project is in the public interest and that the benefits provided by the Project outweigh the risks of significant adverse environmental, social and heritage effects (<http://www.newsroom.gov.bc.ca/2014/10/site-c-project-granted-environmental-assessment-approval.html>). The Ministers have issued an Environmental Assessment Certificate (EAC) setting conditions under which the Project can proceed.

Further, on November 25, 2014, The Minister of Environment of Canada issued a Decision Statement confirming that, while the Project has the potential to result in some significant adverse effects, the Federal Cabinet has concluded that those effects are justified in the circumstances. The Decision Statement sets out the conditions under which the Project can proceed.

1.6 Development of Mitigation, Management and Monitoring Plans

Mitigation, management and monitoring plans for the Project have been developed taking into account the measures proposed in the EIS, information received during the Joint Review Panel hearing process, and the Report of the Joint Review Panel on the Project. Those plans are consistent with, and meet requirements set out in, the conditions of the Environmental Assessment Certificate and of the Decision Statement issued on October 14, 2014 and November 25, 2014 respectively.

In addition, in accordance with environmental best practices (Condition 3.1), these plans were informed by the best available information and knowledge, based on validated methods and models, undertaken by qualified individuals and apply the best available economically and technologically feasible mitigation strategies. These plans contain provisions for review and update as new information on the effects of the Project and on the efficacy of the mitigation measures become available.

2.0 Aboriginal Group Communication Plan

2.1 Objective and Scope

The objective of the Aboriginal Group Communication Plan (the “Plan”) is to establish a communications program for informing Aboriginal harvesters about construction activities related to the Site C Project (the “Project”) that may affect their harvesting opportunities for plants, fish and game, as well as access to those opportunities. This Plan is aligned with the Construction Communication Plan.

This Plan has been developed in accordance with the following Conditions 27 and 72 of the Environmental Assessment Certificate (EAC) and Condition 14.2 of the federal Decision Statement (FDS), as indicated in the table below.

EAC 27, 72 and FDS 14.2

Condition Number	Condition	Plan Reference
------------------	-----------	----------------

Condition Number	Condition	Plan Reference
EAC Condition 27	In order to manage adverse effects on Aboriginal plant, fish and game harvesters during both the construction and operations phases of the Project, the EAC Holder must develop, as part of the Construction Communication Plan, a communications program (Program) for informing Aboriginal harvesters about construction activities that may affect their harvesting opportunities for plants, fish, and game, as well as access to those opportunities.	
	The Program must also include information regarding how fish monitoring programs will be used to inform Aboriginal harvesters about changes in fish community composition during operations.	Section 5.0 Key Activities and Tools
	The EAC Holder must make all reasonable efforts to develop the draft Program in collaboration with FLNR and Aboriginal Groups, at least 90 days prior to Project activities that may affect Aboriginal harvesting opportunities.	
	The EAC Holder must file the final Program with EAO, FLNR and Aboriginal Groups at least 30 days prior to any activities that may affect Aboriginal harvesting opportunities.	
	The EAC Holder must develop, implement and adhere to the final Program, and any amendments, to the satisfaction of EAO.	
EAC Condition 72	<p>The EAC Holder must manage effective communications for the Project by implementing measures in communication plans and a business participation plan.</p> <p>The following communication and participation plans are to be developed and implemented:</p> <ul style="list-style-type: none"> • Business Participation Plan; • Construction Communication Plan; and • First Nations Communication Plan. 	
	Each plan in addition to plan specific conditions identified in this document will include:	
	<ul style="list-style-type: none"> • Clear Statement of Objectives; 	Section 3.0 Scope of Plan
	<ul style="list-style-type: none"> • Audiences; 	Section 4.0 Audiences
	<ul style="list-style-type: none"> • Key activities and tools; and 	Section 5.0 Key Activities and Tools

Condition Number	Condition	Plan Reference
	<ul style="list-style-type: none"> Annual summary reporting. 	Section 6.0 Plan Reporting Requirements
FDS Condition 14.2	The Proponent shall inform Reservoir Area Aboriginal groups and Immediate Downstream Aboriginal groups about Designated Project activities that may affect the current use of lands and resources for traditional purposes including harvesting of plants, fish and wildlife and access to land for the purposes of those uses.	

2.2 Consultation

Many of the conditions require BC Hydro to consult or collaborate with certain government agencies and Aboriginal groups in respect of measures and plans required by the conditions.

BC Hydro began consultation on the Project in late 2007, before any decision to advance the Project to an environmental assessment. BC Hydro’s consultation with the public, stakeholders, regional and local governments, regulatory agencies, and Aboriginal groups is described in EIS Section 9, Information Distribution and Consultation.

Additional information on the consultation process and a summary of issues and concerns raised during consultation are provided in:

- Volume 1 Appendix G, Public Information Distribution and Consulting Supporting Documentation
- Volume 1 Appendix H, Aboriginal Information Distribution and Consultation Supporting Documentation
- Volume 1 Appendix I, Government Agency Information Distribution and Consultation Supporting Documentation
- Volume 5, Appendix A01 to A29, Parts 2 and 2A, Aboriginal Consultation Summaries
- Technical Memo: Aboriginal Consultation

Draft versions of a number of the mitigation, management and monitoring plans required by the conditions were submitted to applicable government agencies and Aboriginal groups for comment on October 17, 2014.

Comments on these draft plans were received from various government agencies and Aboriginal groups during November and December 2014, and were considered in the revisions to these plans. BC Hydro’s consideration of these comments is provided in the consideration tracking tables that accompany each plan.

On December 15, 2014, Treaty 8 Tribal Association (T8TA), on behalf of West Moberly, Saulteau and Prophet River First Nations, submitted to BC Hydro a letter in response to BC Hydro’s request for comment on the Plans sent on October 17, 2014. The letter included several appendices, including the Joint Review Panel (JRP) Report and transcripts from the JRP hearings in December 2013 and January 2014. BC Hydro responded to the three First

Nations on January 21, 2015 noting that the October 17 2014 request for comments on the plans was to provide an opportunity to the First Nations to submit to BC Hydro any information they wanted to provide in relation to the Plans. BC Hydro advised that it was aware of the information referred to in T8TA's letter when the plans were prepared, and advised that it was preparing a table setting out where any mitigation measures identified by representatives of the three First Nations during the hearings are considered in the draft plans and would provide that to the First Nations once complete. Accordingly BC Hydro's responses to those mitigation measures identified by the representatives of the three First Nations during the JRP hearings were provided to the EAO in a separate table by letter dated May 19, 2015. Aside from the December 15, 2014 letter, BC Hydro has not received further comments from these First Nations. A letter of understanding dated April 30, 2015 respecting provision of capacity funding to support review of the plans was entered into by BC Hydro and Saulteau First Nations (on behalf of Saulteau, West Moberly and Prophet River First Nations).

New draft plans (i.e., Housing Plan and Housing Monitoring and Follow-Up Program, and the quarry/pit development plans) were provided to the entities identified in the EAC conditions on April 7, 2015. The Vegetation and Wildlife Mitigation and Monitoring Plan was revised based on comments received on the October 17, 2014 version and based on discussions with Environment Canada and the BC Ministry of Environment, and was re-submitted to applicable entities on April 7, 2015.

Comments on the revised plans were requested by May 11, 2015 to allow for review, consideration of comments and finalization of the plans 30 days prior to the commencement of construction.

Comments were received by this requested date from:

- Fort Nelson First Nation
- Ministry of Forests, Lands and Natural Resource Operations (FLNRO), and
- Métis Nation British Columbia.

The Peace River Regional District submitted their comments on the plan on May 14, 2015. FLNRO submitted additional comments on May 15, 2015, including comments from the BC Ministry of Environment.

BC Hydro considered the comments provided and prepared final plans. On May 19, 2015, BC Hydro submitted the following mitigation, management and monitoring plans to the BC Environmental Assessment Office (BC EAO) for review:

- Construction Environmental Management Plan
- Construction Safety Management Plan
- Fisheries and Aquatic Habitat Management Plan
- Vegetation and Wildlife Mitigation and Monitoring Plan
- Vegetation Clearing and Debris Management Plan
- Aboriginal Plant Use Mitigation Plan
- Aboriginal Training and Inclusion Plan
- Business Participation Plan

- Emergency Services Plan
- Healthcare Services Plan
- Labour and Training Plan
- Cultural Resources Mitigation Plan
- Heritage Resources Management Plan
- Housing Plan and Housing Monitoring and Follow-Up Program
- Wuthrich Quarry Development Plan
- West Pine Quarry Development Plan; and
- Del Rio Pit Development Plan.

The CEA Agency and Environment Canada submitted comments on the revised plan on May 22, 2015. These comments were considered and the final plans were revised accordingly and submitted on June 5, 2015 to the entities identified in the EAC conditions.

3.0 Scope of Plan

This Plan covers communications activities during construction of the Project and has been prepared in fulfillment of BC Hydro's mitigation commitments described in section 19 of the EIS:

- *Develop a communications program to inform harvesters of planned or unplanned events related to construction activities that may affect fishing opportunities or access.*
- *Develop a communications program to inform harvesters of planned or unplanned events related to construction activities that may affect hunting opportunities or access.*
- *Develop a communications program to inform harvesters of planned or unplanned events that may affect opportunities to harvest plants, berries, and other resources.*

BC Hydro understands that the Project Activity Zone, as defined in the EIS, overlaps with areas identified as important by Aboriginal groups, including:

- the Peace Moberly Tract;
- Areas adjacent to Saulteau and West Moberly First Nations communities; and,
- Areas used for fishing in the Moberly, Halfway and Peace Rivers.

4.0 Audiences

The following Aboriginal groups have been identified as the audience for this Plan:

- Blueberry River First Nations
- Dene Tha' First Nation
- Doig River First Nation
- Duncan's First Nation
- Fort Nelson First Nation
- Halfway River First Nation
- Horse Lake First Nation

- Kelly Lake Métis Settlement Society
- McLeod Lake Indian Band
- Métis Nation British Columbia
- Prophet River First Nation
- Saulteau First Nations
- West Moberly First Nations

5.0 Key Activities and Tools

This Plan comprises the general activities and tools that will, at minimum, form part of the construction communications program. In addition to what is reflected in this plan and as part of the consultation process, BC Hydro and individual Aboriginal groups may develop communication tools that work best for the specific community.

The following communications activities, described in section 3 of the Construction Communication Plan, will also be used to communicate with Aboriginal groups about construction activities:

- Project website;
- Advertising;
- Construction Information Telephone Line;
- Construction Notices;
- Email updates;
- Mailings;
- Information Materials;
- Social Media;
- Signage;
- Community Consultation Offices;
- Open Houses; and,
- Community Liaison Committees.

In addition, BC Hydro will conduct the following activities to engage with Aboriginal groups to inform Aboriginal harvesters about construction activities that may affect their harvesting opportunities for plants, fish and game, as well as access to those opportunities:

- **Notification Letters of Construction Activities:** BC Hydro will provide updates and advance notice of planned construction activities on a quarterly basis. The first construction notification letter was distributed on July 8, 2015.
- **Communication Forum:** BC Hydro has created and invited Aboriginal groups to participate in a Communication Forum to discuss and share information regarding construction-related topics. The Forum held its first meeting on November 26, 2015 and will meet on a bi-annual basis.

- **Site C Information for Aboriginal Group SharePoint Site:** BC Hydro has established a central online repository for sharing information with Aboriginal groups. Information posted to this site includes Environmental Protection Plans, Monthly Environmental Monitoring Reports, materials from meetings for the Communication Forum and Culture and Heritage Resources Committee, construction notifications and other reports.
- **Culture and Heritage Resources Committee:** A Culture and Heritage Resources Committee has been established with Aboriginal groups to advise BC Hydro on the management of adverse Project effects on cultural resources. The Committee initially met on July 30, 2015 and meets as determined by the Committee members. The Committee provides opportunities for discussion and information exchange, as well as the development of mitigation measures related to cultural and heritage resources.
- **Aboriginal Harvesters Information Sheet:** an information sheet containing regular updates on construction activities.
- **Saulteau Trappers Protocol:** BC Hydro has developed, in collaboration with Saulteau First Nation Trapline holders, a protocol for notification of work taking place in their respective traplines related to the Project. This protocol was initiated in 2013 and will continue through the construction phase of the Project.
- **Consultation meetings:** BC Hydro will continue to consult Aboriginal groups through the construction phase of the Project. From time to time and as appropriate, consultation meetings can be used to provide updates to communities about construction activities that may affect their land users.
- **Fish Monitoring Program:** BC Hydro will communicate results of the Fisheries and Aquatic Habitat Monitoring and Follow-up Program which includes as part of the a Site C Reservoir Fish Community monitoring program to assess the effects of river to reservoir transformation on the fish community in the Site C Reservoir and associated tributaries . Aboriginal groups will be provided with monitoring reports annually. Community-based meetings with Aboriginal groups could be held to share these results and inform the communities on changes to the fish community composition.

6.0 Plan Reporting Requirements

On an annual basis, BC Hydro will provide to the Environmental Assessment Office and the Canadian Environmental Assessment Agency a summary report of its activities carried out under this Plan.

Appendix E Acid Rock Drainage and Metal Leachate Management Plan

SITE C CLEAN ENERGY PROJECT

Appendix E

ACID ROCK DRAINAGE AND METAL LEACHATE MANAGEMENT PLAN

REVISION 6.1

Original Prepared by:

Klohn Crippen Berger Ltd. and SNC-Lavalin Inc.

**For BC Hydro
February 26, 2015**

**Modified by BC Hydro, July 26, 2016, September 4, 2020, January 17, 2022,
October 4, 2023**

Table of Contents

Revision History	3
List of Acronyms.....	6
1.0 Objective.....	7
2.0 Background.....	7
2.1 ARD and ML.....	7
2.2 Mitigation Approaches.....	8
3.0 Geochemical Characterization Program.....	8
3.1 Status.....	9
3.2 ARD and ML Results.....	10
3.3 Water Quality Predictions and Reference Concept Design.....	11
3.4 Future Work.....	11
4.0 Regulations and Guidelines.....	12
4.1 Statutory Requirements.....	12
4.2 BC Hydro Policies.....	12
4.3 Voluntary Commitments.....	12
5.0 Mitigation and Environmental Protection Measures.....	13
5.1 General Approach	13
5.2 Site Specific Mitigation	14
5.2.1 Dam Site Area	14
5.2.1.1 Dam Site Excavations.....	14
5.2.1.2 RSEMs.....	15
5.2.1.3 North Bank RSEM Area L5 Management Measures	16
5.2.1.4 North Bank RSEM Area L6 Management Measures.....	17
5.2.1.5 South Bank RSEM Areas R5a and R5b Management Measures.....	17
5.2.1.6 South Bank RSEM Areas R6 Management Measures.....	18
5.2.1.7 Dam Site Road Cuts.....	18
5.2.2 Off Dam Site Project Components, including Highway 29 Realignment Segments and Hudson’s Hope Shoreline Protection	19
5.2.3 Borrow Materials.....	22
6.0 Training Qualifications	22
6.1 Qualified Professionals, roles and responsibilities	23
6.1.1 River mixing dynamics Qualified Professional.....	23
6.1.2 ARD ML Qualified Professional (herein referred to as QP(ARD)).....	23

7.0	ARD and ML Compliance, Monitoring, Mitigation, Reporting and Adaptive Management.....	23
7.1	Objectives	23
7.2	Compliance Requirements.....	24
7.2.1	Toxicity.....	24
7.2.2	RSEM end of pipe water quality.....	24
7.2.3	Peace River water quality downstream of each RSEM.....	25
7.2.4	PAG contact RSEM sediment.....	25
7.2.5	Groundwater below PAG contact RSEMs.....	25
7.3	RSEM, Groundwater and Peace River Monitoring	26
7.3.1	Toxicity monitoring	26
7.3.2	PAG containing RSEM material and contact water monitoring	27
7.3.3	RSEM 5a and 5b groundwater monitoring	28
7.3.4	Peace River water quality monitoring	28
7.4	Mitigation.....	29
7.4.1	PAG Containing RSEM pond mitigation	29
7.4.2	Exceedance Response Plan.....	29
7.5	Reporting.....	29
7.5.1	RSEM 5a and 5b groundwater monitoring	30
7.5.2	RSEM PAG material and contact water monitoring	30
7.5.3	Peace River monitoring	30
8.0	Qualified Environmental Professionals.....	30
9.0	References	31

Revision History

Version	Date	Comments
Revision 4	02-26-2015	
Revision 5	07-18-2016	<ul style="list-style-type: none"> ○ Added revised water quality monitoring and compliance requirements and approach for reviewing monitoring results and adapting treatment programs accordingly to ensure compliance with water quality requirements. ○ Removed reference to MMER guidelines for effluent quality. ○ Updated RSEM management objectives based on new geochemical characterization information ○ Added Qualified Professional designations and experience requirements and decision points where this Qualified Professional is required
Revision 5.1	07-25-2016	<ul style="list-style-type: none"> ○ Added revisions suggested by IEM, including broadening activities at L3, adding road cut exposed rick faces, clarified Table 2 guidelines and which ones must be met, increased frequency of pH and turbidity sampling at RSEMs (required continual sampling via an automatic sampler), added the requirement to monitor far-field site in S7.3.4, re-arranged paragraphs in 7.3.2 and added a new section (S. 7.4.2) to better explain the exceedance response plan.
Revision 5.2	07-26-2016	<ul style="list-style-type: none"> ○ Corrected minor spelling errors, added clarity to requirements for non-RSEM sediment ponds that may contain PAG material contact runoff. ○ Added requirement to continuously monitor flow, pH, turbidity and conductivity in PAG-contact RSEM sediment ponds. ○ Clarified monitoring and reporting requirements, including increased frequency of monitoring to weekly/monthly.
Revision 5.3	09-04-2020	<ul style="list-style-type: none"> ● Updated s 3.1 (Status), s 3.2 (ARD and ML Results), s 5.2.2 (Off Dam Site Project Components, including Highway 29 Realignment Segments and Hudson’s Hope Shoreline Protection) as a result of progression of project design, geochemical characterization, and construction ● Updated s 7.3.1 (Toxicity Monitoring) and s 7.3.4 (Peace River Water Quality Monitoring) to reflect the alternate toxicity monitoring program accepted by regulators in February 2019 ● Updated s 9.0 (References)
Revision 6.0	17-01-2022	<ul style="list-style-type: none"> ● Updated Sections 6.1.1, 6.1.2, 7.0, 7.2.2, 7.3.2, 7.4.1, 7.5.2, and 7.5.3 to reflect revisions to the water quality sampling program based on lessons learned during construction to date in accordance with an adaptive management approach, and areas of redundancy with other sections of the CEMP ● Updated Table 2 end-of-pipe limits to reflect a site-specific toxicological assessment undertaken
Revision 6.1	04-10-2023	<ul style="list-style-type: none"> ● Updated S 3.0 Geochemical Characterization Program <ul style="list-style-type: none"> ● Updated text to reflect current status of the program. ● Updated S 5.1 (General Approach) <ul style="list-style-type: none"> ● Updated text to clarify meaning of “General Approach” and reflect that alternate approaches beyond those described in

Version	Date	Comments
		<p>the “General Approach” may be implemented by a QP(ARD).</p> <ul style="list-style-type: none"> • Separated “General Approaches” into those approaches for the “Bulk Damsite Excavations and RSEMS” and “Other Excavations, Road Cuts, Borrow Areas and Miscellaneous Chance Finds”. • Updated text to allow covering AG and PAG material in material with low permeability to minimize infiltration and leachate. • Updated S 5.1.2 (Other Excavations) <ul style="list-style-type: none"> • Clarified that section addresses dam site PAG exposures that are not part of the bulk damsite excavations or RSEMS. • Updated S 5.2 (Site Specific Mitigation) <ul style="list-style-type: none"> • Specifies that Mitigation will be described according to Sites as set out in subsections under this heading. • Updated S 5.2.1.7 (Dam Site Road Cuts) <ul style="list-style-type: none"> • Added clarity on surface water collection and diversion on the North and South banks of the Peace River. • Added reference to safety requirements for sampling personnel. • Updated S 5.2.2 (Off Dam Site Project Components) <ul style="list-style-type: none"> • Added clarification to Section title by adding “Off Dam Site Project Components”. • Added clarification that ARD-ML management is required for any off-dam site component of the project where PAG materials are excavated. • Added geochemical characterization information for off dam site project areas and management approaches for Highway 29 realignment and Hudson’s Hope Shoreline Protection. • Added ARD-ML management approach for exposed PAG slopes, PAG Stockpiles and Storage, Site Drainage, and Incidental PAG exposures. • Added EPP requirements for PAG water management regarding connectivity, exceedance event triggers, notification requirements, sampling, monitoring, and treatment. • Clarified PAG stockpiles may be covered when placement is finished with different options, including synthetic covers layers. • Clarified QP(ARD) may prescribe a duration other than 30 days before a cover is required based on monitoring results. • Clarified QP(ARD) PAG mitigation strategy options. • Clarified QP(ARD) PAG water quality monitoring and reporting requirements. • Added requirement to provide IEM verification of whether or not sampled water reached the aquatic receiving environment. • Reworded statement about water quality sampling upstream of the PAG contact area and prior to entering the receiving environment.

		<ul style="list-style-type: none">• Added detail on how QP(ARD) determines if monitoring or mitigation is required.• Updated S 5.2.3 (Borrow Materials)<ul style="list-style-type: none">• Clarified that shale rocks at the base of borrow pits can be mitigated by maintaining a cover of non-PAG natural materials or synthetic cover over the surface as prescribed by the QP(ARD).
--	--	---

List of Acronyms

AG	Acid Generating
ARD	Acid Rock Drainage
EIS	Environmental Impact Statement
EPP	Environmental Protection Plan
ML	Metal Leaching
PAG	Potentially Acid Generating
RSEM	Relocated Surplus Excavated Materials
QP(ARD)	Qualified Professional for the identification and management of AG, ARD and ML related issues
WQM	Water Quality Model

1.0 Objective

The objective of this Acid Rock Drainage and Metal Leachate Management Plan (the Plan) is to describe the measures that will be undertaken to mitigate potential adverse effects on the receiving environment resulting from known or potential sources of acid rock drainage (ARD) and / or metal leaching (ML) material.

This Plan describes the measures that will be adopted to effectively dispose of materials that will be excavated, exposed or disturbed during the construction of the Site C Clean Energy Project (the Project) so that there is an insignificant change in pH, total metals and dissolved metals upstream and downstream of the dam site as a result of Project construction.

The Plan:

- Describes the procedures for managing and storing surplus excavated materials during construction of the Project;
- Establishes new performance criteria to ensure the PAG contact RSEM sediment pond effluent and non-RSEM sediment pond PAG contact runoff meets Provincial requirements; and
- Establishes various monitoring programs during construction of the Project to assess the performance of material management and storage strategies and ensure compliance with performance criteria

The earlier version of the plan was based on the latest results from the geochemical characterization program presented in KCB and SLI (2014a, 2014b, and 2014c).

Additional geochemical characterizations and receiving environment mixing analysis have since been undertaken, and these new analyses inform the present Plan.

To ensure this Plan remains current, it will be updated at a minimum of once per year or as required based on Project and geochemical characterization program advancements.

2.0 Background

The Plan includes risk-based planning and design approaches to quantify the long-term impacts of mitigation option(s) and select the most appropriate mitigation option(s). Mitigation measures include on-going geochemical testing and analysis of materials that will define handling and storing plans to reduce source loading discharges and minimize long-term monitoring and maintenance requirements.

2.1 ARD and ML

ARD and ML occur when sulphide minerals react with oxygen, ferric iron and water to produce sulphuric acid. Sulphuric acid could then leach metals thereby further increasing the acidity and producing sulphates, and metals. ARD resulting from the Project may result in ML release, but leaching under neutral conditions may also occur.

Furthermore, ARD can be neutralized with the addition or presence of carbonate minerals.

2.2 Mitigation Approaches

The primary approaches to preventing and mitigating ARD and ML are to minimize the supply of the primary reactants for sulphide oxidation and / or maximize the availability of acid neutralizing minerals. Examples of these approaches include one or a combination of the following:

- Minimize oxygen
- Minimize water and moisture
- Minimize, remove or isolate sulphide minerals
- Adjusting pore water seepage pH
- Maximize acid neutralizing minerals and pore water alkalinity
- Control bacteria and biogeochemical processes

3.0 Geochemical Characterization Program

The purpose of the geochemical characterization program was to determine the risk of ARD and ML at the Project components.

The geochemical characterization program used a phased approach to characterize the risk of ARD and ML and included a range of both static and kinetic tests.

- Static testing included:
 - Elemental analysis
 - Mineralogy
 - Acid base accounting
 - Leachate extraction
- Kinetic testing included:
 - Humidity cells
 - Field leach barrels
 - Field leach pads
 - Wall wash stations

In addition to these tests, modeling to predict the water quality has been completed.

3.1 Status

EIS Volume 2 Section 11.2.4 Geochemistry summarizes the geochemical characterization program completed to the end of 2012. The results from the geochemical characterization program are presented in geochemical reports by Klohn Crippen Berger and SNC Lavalin (KCB and SLI 2014a, 2014b, and 2014c), which summarize the program to the end of 2013.

The 2014 testing has included:

- Shake flask extraction tests to assess the potential for ML at Wuthrich Quarry, Howe Pit, Area A, 85th Avenue Industrial Lands, and dam site bedrock;
- Humidity cells to assess the rate of ARD and ML at the dam site and West Pine Quarry;
- Wall wash station to assess the water quality of surface runoff from West Pine Quarry;
- Water quality samples from a wall wash station and field runoff pad to assess surface runoff of the dam site bedrock;
- Ongoing field leach barrels to assess any changes in water quality overtime of dam site materials;
- Ongoing field leach pad operation and monitoring to assess any changes to water quality overtime of the dam site bedrock;
- Acid base accounting to further characterize the ARD potential of the dam site bedrock; and
- Water quality samples from seeps from right bank of the dam site area to assess background water quality.

Geochemical characterization has been carried out along the Highway 29 corridor to assess the potential for ARD-ML generation from bedrock associated with areas offsite of the MCW area which are undergoing construction and excavation. Geochemical characterization includes programs completed to the end of 2019. The latest results from the geochemical characterization program are summarized in geochemical reports by Tetra Tech (2020a, 2020b, 2020c, 2020d, 2020e). Available Data includes:

- Acid base accounting data for bedrock from Dry Creek, Farrell Creek, Bear Flat Cache Creek, Lynx Creek and Halfway River;
- Total element analysis from Dry Creek, Farrell Creek, Bear Flat Cache Creek, Lynx Creek and Halfway River; and,

- Leachable metal analysis from Dry Creek, Farrell Creek, Lynx Creek and Halfway River.

3.2 ARD and ML Results

A summary of the ARD and ML potential at each Project component is presented in Table 1. These results are based on the latest results of the geochemical characterization programs (KCB & SLI 2014a, 2014b, and 2014c), and as summarized in Tetra Tech (2020a, 2020b, 2020c, 2020d, 2020e).

Characterization and management plans of material were initially focused on the dam site bedrock since it was disturbed earliest to construct the Project. Characterization and management plans of materials at other Project components are either complete or will continue to advance as their construction schedules approach.

Table 1 Project Components ARD and ML Potential

Project Component	Location	Material	Potential for ARD	Potential for ML	Management Plan Required
Dam Site Area	Dam Site	Bedrock	High	Yes	Yes
	Dam Site	Overburden	No	Very Low	No
Highway 29 Realignment	Highway 29 Realignment	Overburden	No	Very Low	No
	Highway 29 Realignment – East of a point 300 m East of Lynx Creek (other than the sites mentioned below)	Bedrock	Yes	Low	Yes
	Bear Flat Cache Creek	Bedrock	Moderate	Unknown	Yes
	Halfway River	Bedrock	Yes	Yes	Yes
	Farrell Creek	Bedrock	Yes	Low	Yes
	Dry Creek	Bedrock	Yes	Yes	Yes
	Highway 29 Realignment - West of a point 300 m East of Lynx Creek (other than the site mentioned below)	Bedrock	Low	Low	Yes
	Lynx Creek	Bedrock	Low	Low	Yes
Hudson's Hope Shoreline Protection	Hudson's Hope	Overburden	No	Very Low	No
	Hudson's Hope	Bedrock	Low to Moderate	Very Low	Yes

Project Component	Location	Material	Potential for ARD	Potential for ML	Management Plan Required
Quarried and Excavated Construction Materials	Riske Pit, Peaceview Pit, Thompkins Pit, Beryl Pit, Southwick Reserve, Ardill Pit, Halfmoon Lake Quarry, Del Rio Pit	Granular road base material	No	Very Low	No
	Portage Mountain Quarry	Rip-rap source material	No	Very Low	No
	Wuthrich Quarry	Rip-rap source material	No	Very Low	No
	West Pine Quarry	Rip-rap source material	No	Very Low	No
	85th Avenue Industrial Lands	Aggregate source material	No	Very Low	No
	Area A	Aggregate source material	No	Very Low	No
	Howe Pit	Aggregate source material	No	Very Low	No
	Riverbed Sand and Gravel	Aggregate source material	No	Very Low	No

3.3 Water Quality Predictions and Reference Concept Design

To further evaluate AG bedrock with an ARD and/or ML potential from the dam site, a runoff water quality model (WQM) was developed for the Relocated Surplus Excavated Material (RSEM) areas. This WQM was based on a reference concept design for the material handling schedule for the Relocated Surplus Excavated Material (RSEM). The reference design includes the layout of water management structures for diversion, collection and storage including sediment ponds, and discharges.

The objectives of the WQM were to predict:

- Water quality of runoff from the RSEM areas and exposed excavated surfaces;
- Water quality at construction discharge points to the receiving environment.

In addition, quality and quantity of seepage through the RSEM column was analyzed again in June 2016. The results of the seepage analysis and the establishment of new RSEM end of pipe water quality criteria in June 2016 concluded that for some RSEM ponds some degree of treatment may be required to maintain contact runoff water within compliance criteria.

3.4 Future Work

Future work will depend on the results of the geochemical characterization program, including the results of the testing listed in Section 3.1.

Additional information from these reports will be incorporated into future versions of the Plan as results become available.

Future work will also include additional characterization and, if required, management procedures for excavated, exposed, and disturbed materials at the other Project components.

BC Hydro has engaged qualified professionals to assist with the development of the Plan. BC Hydro will continue to work with regulators in the development of the Plan.

4.0 Regulations and Guidelines

4.1 Statutory Requirements

The legislation that contains provisions relevant to prevention and management of ARD and ML include the federal *Fisheries Act*, and the provincial *Environmental Management Act* and the *Fish Protection Act*. If the drainage or leachate of the material has the potential to affect surface water or groundwater, then the *Water Sustainability Act* and *Groundwater Protection Act* will also apply.

4.2 BC Hydro Policies

The applicable corporate policy is the Environmental Responsibility Policy (BC Hydro 2010 – see CEMP Section 1.3).

4.3 Voluntary Commitments

The ARD and ML Management Plan is consistent with relevant management practice guidelines, which includes:

- Policy for Metal Leaching and Acid Rock Drainage at Minesites in British Columbia, Ministry of Energy and Mines and Ministry of Environment, Lands and Parks, July 1998
- Guidelines for Metal Leaching and Acid Rock Drainage at Minesites in British Columbia, Ministry of Energy and Mines, August 1998
- DRAFT Guidelines and Recommended Methods for the Prediction of Metal Leaching and Acid Rock Drainage at Minesites in British Columbia, Ministry of Employment and Investment, April 1997
- List of Potential Information Requirements in Metal Leaching/Acid Rock Drainage Assessment and Mitigation, Mine Environment Neutral Drainage Report 5.10E, January 2005
- Prediction Manual for Drainage Chemistry from Sulphidic Geologic Materials, MEND Report 1.20.1, December 2009
- The Global Acid Rock Drainage Guide, http://www.gardguide.com/index.php/Main_Page, International Network for Acid Prevention INAP, 2012

- British Columbia Ministry of Environment Approved and Working Water Quality Guidelines

5.0 Mitigation and Environmental Protection Measures

5.1 General Approach

5.1.1 Bulk Damsite Excavations and RSEMs

The primary approaches to mitigate ARD and ML for the Project at damsite bulk excavations and RSEMs, consistent with Section 2.2 Mitigation Approaches, are to minimize the sulphide mineral exposure to air and water by:

- Reducing the time of exposure of excavated surfaces and fill areas that contain AG and PAG material;
- Encapsulating AG and PAG material in material with a low permeability to minimize infiltration and leachate; and
- Storing AG and PAG material within the reservoir footprint to significantly reduce reaction rates by minimizing oxygen.

In addition, any surface runoff from exposed or excavated surfaces that contain AG and PAG material will be captured and, if required, treated prior to discharge. Proposed mitigation and treatment for different Project components are described in Section 5.2.

Implementation of the mitigation measures in the Plan will be a contractual requirement to the contractor. The details of how the contractor will sequence the construction work and meet the requirements of this Plan will be provided in the contractor's Environmental Protection Plan (EPP).

During construction runoff from disturbed areas will be collected and directed towards sedimentation ponds. Discharges shall meet the concentration limits specified in Table 2. Details regarding the locations and frequency of monitoring of sedimentation pond discharges will be provided in the contractor's EPP.

5.1.2 Other Excavations, Road Cuts, Borrow Areas and Miscellaneous Chance Finds

This section addresses dam site PAG exposures that are not part of bulk damsite excavations or RSEMs. Approaches to mitigating PAG exposures in this Section will be consistent with Section 2.2, Mitigation approaches and will either be developed under the direction of a QP(ARD) or follow designs that accompany constructed features (e.g., bridge abutments excavated into PAG material). These approaches will consider technical constraints, including but not limited to, the location of PAG material (e.g., above the reservoir), steepness of slope, or lack of access. As further described in Section 5.2, alternate approaches to mitigation may include monitoring and, if required, treatment of surface water that has contacted AG or PAG material.

5.2 Site Specific Mitigation

The proposed mitigation measures for the respective Project sites are described below.

5.2.1 Dam Site Area

The dam site general arrangement including excavations and RSEM areas are shown in Figure 1. The intent at the dam site is to excavate materials and manage RSEM areas and exposed excavated surfaces in a manner that controls the discharge of surface water into the Peace River to maintain Acceptable Water Quality, as described in Section 7.

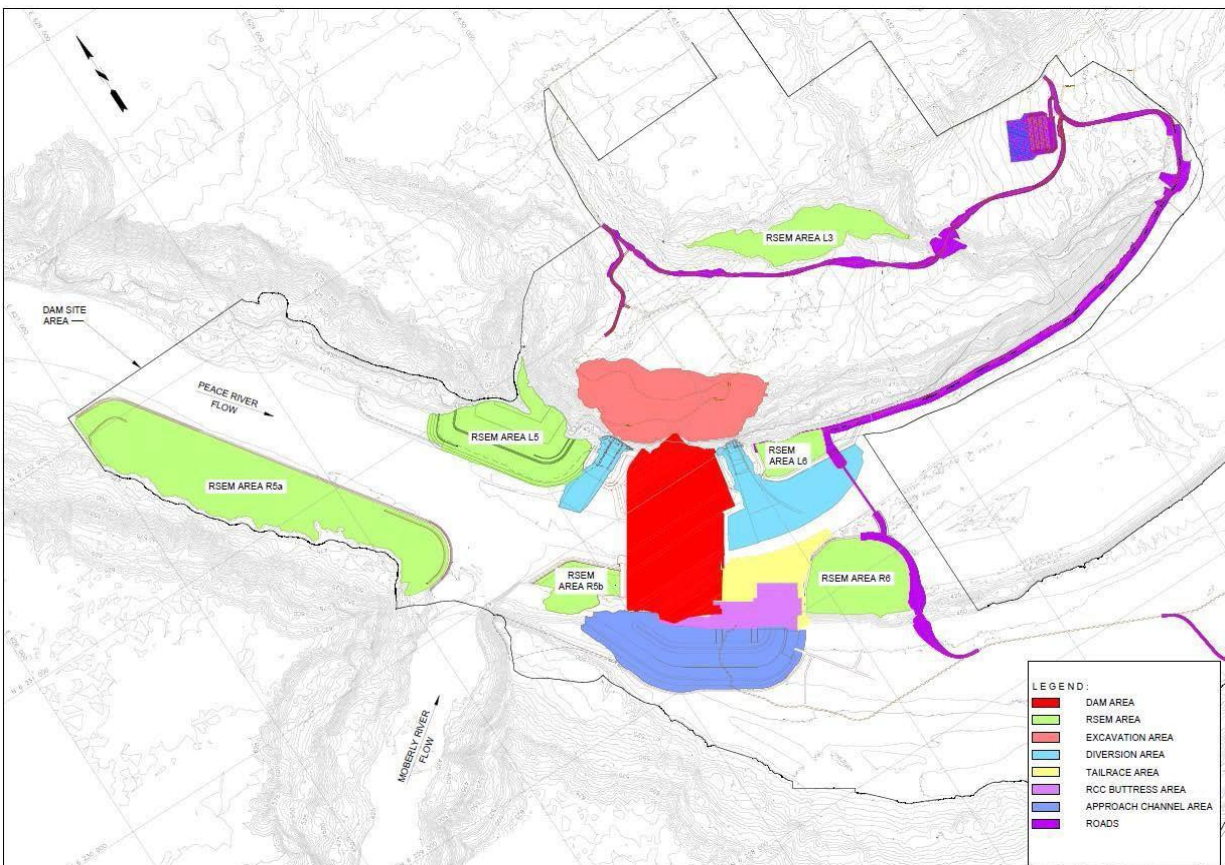

Figure 1 – View of the Dam site area and significant project components

5.2.1.1 Dam Site Excavations

A large bedrock excavation is required to construct the dam, generating station, and spillways. These excavated surfaces will be isolated from the river by the Stage 1 and Stage 2 cofferdams, described in EIS Volume 1 Section 4.4.3. The cofferdams will have cut-offs that penetrate through the riverbed alluvium and into the underlying bedrock so that precipitation, runoff from excavated slopes or seepage will be contained within the cofferdams.

Where practical, upslope runoff will be diverted away from the excavation areas to minimize the amount of water that has to be collected. Water will be collected between the cofferdams, and, if required, treated prior to discharge into the Peace River.

During construction the excavated slopes will be monitored and, if required, temporary covers will be placed on the excavation slopes to mitigate ARD and ML. The majority of the excavated bedrock surfaces will be permanently covered by earth fill and concrete structures that will minimize future sulphide oxidation. Areas that are not covered will be monitored and treated, if required, to maintain Acceptable Water Quality, as described in Section 7.

Runoff WQM predictions based on the reference concept design (see Section 3.3), indicate that a combination of physical treatment via sediment pond and chemical treatment may be required to maintain Acceptable Water Quality, as described in Section 7 for the dam site excavations.

5.2.1.2 RSEMs

Unsuitable construction material, including dam site bedrock will be relocated to the RSEM areas. Where applicable, RSEM areas will be isolated from the river with perimeter dykes designed to withstand erosion by wave action and river currents.

To limit infiltration and leachate, the AG and PAG materials placed in the RSEM areas will be encapsulated with low permeability natural materials or covered with neutral natural materials available on site. Furthermore, the majority of the AG and PAG materials will be relocated upstream of the dam and permanently submerged in the reservoir. This will inhibit ARD and ML production.

The contractor will be required to:

- Divert upslope runoff away from the RSEM areas to minimize the amount of contact water, where practical.
- Manage the placement of AG and PAG materials and non-PAG covering materials to minimize/prevent the generation of ARD and ML
- Monitor pH of placed AG and PAG material and modify placement and encapsulation, as required to mitigate as much as practicable against occurrence of low pH;
- Implement and report on monitoring activities at each RSEM to ensure compliance with water quality criteria (see Section 7)
- Proactively plan for, manage and implement a progressive water treatment program, based on the results of rock pH testing and contact water quality monitoring with review and documented direction from the QP(ARD) (see Section 6.1), to ensure compliance with water quality criteria (see Section 7)

Overburden from the north bank excavations will be relocated to RSEM Area L3. This RSEM area is located in a gully on the north bank and is not adjacent to the Peace River.

A reference concept design to mitigate the risk of ARD and ML generation and to manage runoff includes the following:

- Only relocate non-PAG overburden to L3;
- Temporary management of Unnamed Creek 3 during construction to minimize surface water contact with the RSEM area;
- Construct the RSEM area in horizontal lifts and compact the surface of each lift to reduce water infiltration and air ingress;
- Install a compacted granular cover on the downstream face to minimize erosion;
- Compact the final surface to minimize infiltration; and
- Landscape the final surface to minimize erosion.

5.2.1.3 North Bank RSEM Area L5 Management Measures

Overburden and bedrock from the north bank and earthfill dam excavations will be relocated to RSEM Area L5. RSEM Area L5 is located on the north bank, upstream of the dam, and will be permanently submerged during operations. A starter dyke will be constructed around the area.

A reference concept design to mitigate the risk of ARD and ML generation and manage runoff includes the following:

- Temporary management of Garbage Creek to minimize contact with the RSEM area;
- Construct the area in horizontal lifts to reduce water infiltration and air ingress;
- Encapsulate the bedrock within compacted overburden materials;
- Construct a granular cover on the final surfaces;
- Monitor pH of placed PAG material and modify placement and encapsulation, as required to mitigate low pH; and
- Monitor, contain and treat, if required, runoff from the RSEM area (see Section 7).

Containment and treatment of runoff from this RSEM area will continue, if required, until reservoir filling when permanent submergence will inhibit ARD and ML generation.

Runoff WQM predictions based on the reference concept design (see Section 3.3), indicate that a combination of PAG AG rock handling and covering combined with physical treatment via sediment pond will likely and chemical treatment may be required to maintain Acceptable Water Quality, as described in Section 7 for the dam site excavations.

5.2.1.4 North Bank RSEM Area L6 Management Measures

Overburden and bedrock from the north bank excavations, including material from the diversion tunnels, are expected to be relocated to RSEM Area L6, which is located on the north bank, downstream of the dam. A starter dyke will be constructed around the area. If no PAG material is placed in RSEM L6 then the PAG material handling and water management requirements in this Plan do not apply.

A reference concept design to mitigate the risk of ARD and ML generation and manage runoff includes the following:

- Construct the area in horizontal lifts to reduce water infiltration and air ingress;
- Place bedrock below the final elevation of the Peace River;
- Encapsulate the bedrock within compacted overburden materials; and
- Monitor pH of placed PAG material and modify placement and encapsulation, as required to mitigate low pH; and
- Monitor, contain and treat, if required, runoff from the RSEM area (see Section 7).

Containment and treatment of runoff from this RSEM area will continue, if required, until the RSEM area is capped with a compacted granular cover.

Runoff WQM predictions based on the reference concept design (see Section 3.3), indicate that a combination of PAG AG rock handling and covering combined with physical treatment via sediment pond and chemical treatment may be required to maintain Acceptable Water Quality, as described in Section 7, for the dam site excavations.

The RSEM area will not be inundated and at the end of construction, it will be graded and vegetated.

5.2.1.5 South Bank RSEM Areas R5a and R5b Management Measures

Overburden and bedrock from the south bank excavations will be relocated to RSEM Area R5a. Overburden will be relocated to RSEM Area R5b. These RSEM areas are located on the south bank, upstream of the dam, and will be permanently submerged during operations. These areas will be constructed and managed as described for RSEM Area L5 except that the AG and PAG materials will be covered with neutral natural materials available on site or with bedrock that has a long lag time before it becomes AG.

A reference concept design to mitigate the risk of ARD and ML generation and manage runoff includes the following:

- Construct the area in horizontal lifts to reduce water infiltration and air ingress;
- Place bedrock below the final elevation of the Peace River;

- Encapsulate the bedrock within compacted overburden materials; and
- Monitor pH of placed PAG material and modify placement and encapsulation, as required to mitigate low pH; and
- Monitor, contain and treat, if required, runoff from the RSEM area (see Section 7).

Containment and treatment of runoff from these RSEM areas will continue, if required, until the RSEM area is capped with a compacted granular cover.

Runoff WQM predictions based on the reference concept design (see Section 3.3), indicate that a combination of PAG AG rock handling and covering combined with physical treatment via sediment pond and chemical treatment may be required to maintain Acceptable Water Quality, as described in Section 7 the dam site excavations.

5.2.1.6 South Bank RSEM Areas R6 Management Measures

In addition to RSEM Areas R5a and R5b, overburden from the south bank excavations could also be relocated to RSEM Area R6, which will be located downstream of the dam. This area will be constructed and filled as described for RSEM Area L3 since it will not contain any bedrock and it will be located downstream of the dam. The area will not be inundated at the end of the construction; therefore it will be graded, covered with a compacted granular cover and vegetated.

If PAG material is temporarily stored in R6, it will be placed on a compacted, impermeable layer and covered. Any runoff water that contacts temporarily stored PAG material will be treated in the same manner as Section 7.

Runoff WQM predictions based on the reference concept design (see Section 3.3), indicate that a combination of PAG AG rock handling and covering combined with physical treatment via sediment pond and chemical treatment may be required to maintain Acceptable Water Quality, as described in Section 7 for the dam site excavations.

5.2.1.7 Dam Site Road Cuts

Two access roads that will cut through the bedrock at the dam site are required for Project construction. These roads are on either side of the Peace River and the sections where bedrock will be exposed are as follows:

- On the north bank, between Howe Pit and the Peace River along River Road; and
- On the south bank, between RSEM Area R6 and Area A and beside the original road cut to the Moberly River Bridge.

Surface water on the north bank and south bank will be diverted to the main stem of the Peace River. Surface water on both banks will be monitored for water quality as part of the site wide water quality monitoring program where safe access allows and when not in dry or frozen conditions. Access must be deemed safe by the Environmental Monitor in accordance with site safety requirements. Any runoff that is non-construction contact related, but may contact PAG material in road cuts, will be monitored (see below) and if water quality concerns are identified, mitigation recommended by the QP(ARD) will be implemented, up to and potentially including collecting all runoff and diverting to a PAG-contact sediment pond for potential treatment prior to release into the environment. The runoff WQM results indicate that treatment may not be required. Should treatment be required, a mitigation plan will be implemented to mitigate the effects of ARD and / or ML.

These sites will be monitored monthly (except while frozen) for the first year of observation then quarterly thereafter during construction by a QP(ARD) retained and managed by BC Hydro. These monitoring inspections will be increased in frequency if ARD and ML is observed and if there is a risk of negative downstream effects such as impacts to runoff water quality. This QP(ARD) will recommend mitigative measures as required to prevent generation of ARD and ML and to ensure site run-off meets BC Water Quality objectives prior to entering any waterbody. BC Hydro will summarize the results of these QP(ARD) investigations, monitoring results and mitigative strategies in its annual reporting and to any regulator and the Independent Environmental Monitor upon request.

Analysis results are to be sent to the IEM immediately in the event an exceedance is identified in any water samples.

It is preferable that the bedrock be disposed of subaqueously, but since these roads will be constructed prior to the construction of RSEM areas, the material will need to be stored temporarily. Suggested storage features to mitigate ARD and ML generation include:

- Locating stockpiles on compacted low permeability pads to minimize infiltration into underlying soils;
- Diverting surface water runoff from adjacent areas away from stockpiles;
- Covering stockpiles with an impermeable membrane; and
- Monitoring any contact water and if required, implement water treatment.

5.2.2 Off Dam Site Project Components, including Highway 29 Realignment Segments and Hudson's Hope Shoreline Protection

Appropriate ARD/ML management is required for any off-dam site component of the project where PAG materials are excavated, including, but not limited to, rock cuts, excavations, use of rock as fill, access roads, exposures for bridge abutments, management of drill cuttings, pile driving, and preparation of worksites.

As summarized in Table 1, geochemical characterization has resulted in the following classifications for off dam site project areas:

- The overburden samples collected from the Highway 29 Realignment Segments and at the Hudson's Hope Shoreline Protection are classified as not PAG but are potentially ML.
- The bedrock samples collected from the Highway 29 Realignment Segments and at the Hudson's Hope Shoreline Protection are classified as PAG and potentially ML.
- The current design of the Hudson's Hope Shoreline Protection does not include excavating or disturbing this rock; hence, it is not anticipated that mitigation will be required.

Managing PAG rock materials includes consideration for treatment of exposed PAG slopes, material storage, and site drainage. Contractors for off dam site project components will prepare an ARD/ML management and mitigation plan as part of the EPP for their scope of work, which will include at a minimum a chance find procedure with respect to shale and PAG rock.

Management of PAG materials along Highway 29 must be in accordance with this CEMP, and is also subject to the Ministry of Transportation and Infrastructure (MOTI) Technical Circular T-04/13, Evaluating the Potential for Acid Rock Drainage and Metal Leaching at Quarries, Rock Cut Sites and from Stockpiled Rock or Talus Materials used by the MOTI. In the event of discrepancy between these documents, this CEMP, Appendix E shall take precedence.

Contractors working on projects along Highway 29 that have bedrock excavation components are required to have a Qualified Professional for the assessment and management of acid rock drainage and metal leaching QP(ARD) – see s 6.1.2). These contractors will have engaged a QP(ARD) and have received acceptance from BC Hydro of their EPP (including a subsection for management and mitigation of ARD/ML) prior to any disturbance, exposure or disposal of bedrock. The EPP will include a description of the water management measures the contractor will implement at the outset of construction to minimize and manage all PAG contact water. If connectivity exists between the site and aquatic environment, the EPP will detail measures to enable water quality sampling upstream of the PAG contact area prior to entering the receiving environment for comparison with receiving environment for comparison with the BC Approved Water Quality Guidelines (Freshwater Aquatic Life) [BC WQG. The Plan will also describe the water quality monitoring that will be conducted, including locations, frequency, type of testing (e.g. *in situ*, laboratory), plus exceedance event triggers and notification requirements. The plan will also include details of the mitigation measures for the following project features, as applicable.

Exposed PAG slopes

Exposed PAG slopes in areas where bedrock excavation has occurred must be monitored and mitigated to minimize PAG contact water and reduce potential environmental impacts. It is the responsibility of the Contractor's QP(ARD) to develop mitigation for exposed PAG slopes on a site and associated water quality sampling and monitoring, if required.

The QP(ARD) may initially use visual observations to identify ARD-ML potential based on known characteristics (e.g., geological layer, precipitate formation resulting from oxygen exposure). Based on these observations the QP(ARD) may recommend sampling in these instances. If water quality or soil data indicate a potential risk to the receiving environment, the QP(ARD) determines if further monitoring or mitigation is required.

Mitigation strategies may include minimizing PAG contact by reducing height and length of

the exposed slope, treatment measures like limestone lined ditches, and covers, including impermeable membrane cover (e.g., low density polyethylene such as 30 mil (0.8 mm) with at least 2-year design life, or equivalent) or natural materials (non-PAG soils).

PAG Stockpiles and Storage

Unsuitable construction material, including excavated bedrock, will be relocated to a dedicated storage area within the future reservoir footprint. Where applicable, bedrock storage areas will be isolated from the river with perimeter dykes designed to withstand erosion by wave action and river currents.

To limit infiltration and leachate, the bedrock materials placed in permanent storage areas will, when placement is finished, be encapsulated with low permeability materials or covered with neutral natural or synthetic cover layers. Materials placed within the reservoir footprint will be permanently submerged in the reservoir, which will inhibit ARD and ML production.

The contractor will:

- Locate stockpiles on compacted low permeability pads to minimize infiltration into underlying soils
- Divert upslope runoff away from the bedrock storage area to minimize the amount of contact water where practical
- Manage the placement of PAG bedrock and non-PAG cover materials to minimize/prevent generation of ARD and ML
- Monitor pH of placed PAG material through monthly rinse pH tests when PAG stockpiles are continuously exposed to the environment for greater than 14 days
- Cover PAG stockpiles which will be exposed for longer than 30 days with either an impermeable cover (e.g., low density polyethylene such as 30 mil (0.8 mm) with at least 2-year design life, or equivalent), or minimum of 30 cm of cover material with greater than 30% fines content). The QP(ARD) may prescribe a duration longer than 30-days before cover is required based on monitoring results.

Site Drainage

Management of site drainage is required to minimize PAG contact water at the site. This includes, but is not limited to, management of ditches, water conveyances and seeps. A primary mitigation strategy shall be to keep non-PAG contact water from being impacted by diverting it around construction related PAG exposures and stockpiles.

In the case that site drainage cannot be prevented from coming into contact with exposed, construction related PAG materials, the Contractor's QP(ARD) may propose and design mitigation strategies for addressing acidic or metalliferous drainage. This can include addition of limestone riprap into ditches to provide neutralization potential. Limestone placement in ditches will become less effective over time with the buildup of precipitates, and maintenance of the ditches and limestones will be required.

Construction area PAG contact surface water will be monitored and compared to BC WQGs as prescribed by the QP(ARD). Monitoring during construction will occur on a minimum monthly frequency (except while frozen or dry) for the first year of construction, then quarterly thereafter to completion of construction. Monitoring post-construction will occur as prescribed by the QP(ARD). During periods of spring melt or high precipitation events, sampling frequency will be increased at the discretion of the QP(ARD) to provide adequate data to assess and document trends in water quality. *In situ* monitoring of pH and electrical conductivity may also be used as a screening tool during such events, to provide early warning of acidity and dissolved metals concentrations.

Monitoring and associated site inspections by the Contractor's QP(ARD) will increase in frequency if ARD and ML is observed and if there is a risk of downstream effects such as negative impacts to receiving environment water quality. If water quality concerns are identified, mitigation recommended by the Contractor's QP (ARD) will be implemented, up to and potentially including water treatment prior to release into the environment.

The extent of water detention and treatment facilities required by the Contractor to meet the responsibilities for protection of the aquatic environment while carrying out the work will depend on a number of factors, including but not limited to the methods and schedule chosen by the Contractor for performing the work; the availability of suitable treatment locations within the worksite, and the weather, etc. If required by the QP(ARD), water treatment facilities will be provided, operated, maintained and removed by the Contractor. Analysis results are to be sent to the IEM immediately in the event an exceedance is identified in any water samples plus verification of whether or not the sampled water reached the aquatic environment.

Incidental PAG Exposures

For any off-damsite work locations where there are incidental amounts of PAG material present which are cumulatively less than 1,000 bank cubic meters (i.e., volume of original rock in situ, prior to blasting and/or excavation) within their work area, the contractor may submit a request to BC Hydro to allow for a special dispensation with respect to management of PAG materials. Such a request must include verification as to volumes of PAG materials identified in the work area site and include an alternate proposal for the use or disposal of these materials. The Contractor must also demonstrate that the site does not contain any environmentally sensitive habitats (such as fish bearing streams) which would be put at risk. The ability to obtain a special dispensation may be dependent upon proximity to and known presence or absence of PAG material at adjacent work sites.

5.2.3 Borrow Materials

Borrow material will be derived from various sources as summarized in Table 1. The borrow materials are not PAG and have a very low potential for neutral metal leaching. If shale rocks are encountered in the base of the borrow pits, they will be mitigated by maintaining a cover of non-PAG material or synthetic cover over the surface as prescribed by the QP(ARD).

6.0 Training Qualifications

Contractor's EPPs shall identify the requirements for training of field staff on how to understand and implement the requirements of this Plan. A qualified professional will provide training to field staff and oversee all monitoring activities. These will include rock sampling for additional ARD and ML characterization, as well as sampling of surface water at various locations.

6.1 Qualified Professionals, roles and responsibilities

6.1.1 River mixing dynamics Qualified Professional

BC Hydro will retain a qualified professional to model river mixing dynamics at each of the RSEM sites to establish the location and depth of the *in-situ* Peace River Initial Dilution Zone sample sites (see Section 7) for each RSEM. This qualified Professional will in writing (with reference to an accurate map) confirm the location of these sample sites. This written confirmation will be provided to the IEM and Regulators.

6.1.2 ARD ML Qualified Professional (herein referred to as QP(ARD))

Contractors will retain and manage a QP(ARD) who will oversee the interpretation of ARD/ML site information and monitoring results and who will detail requirements for upslope mitigation (e.g., covering PAG materials) and for progressive ARD/ML contact runoff water treatment requirements at RSEM sites to ensure compliance with end-of-pipe water quality requirements (see Section 7). Contractors shall propose this QP(ARD) to BC Hydro's Representative for acceptance. Only accepted QP(ARD) can perform the duties outlined in this Section.

BC Hydro will also retain a QP(ARD) to inspect and monitor various non-RSEM potential PAG/ML sites (see Section 5) across the Project area on a quarterly basis until they determine inspections of a site are no longer required. This QP(ARD) will prepare and approve written documentation of the inspections, any prescriptions to mitigate negative effects of ARD/ML, and any required maintenance of mitigative measures. These written reports and recommendations will be provided to Regulators and the IEM upon request.

7.0 ARD and ML Compliance, Monitoring, Mitigation, Reporting and Adaptive Management

In order to measure the effectiveness of the mitigation measures implemented, a monitoring and mitigation program will be undertaken to manage potential ARD and ML from construction activities.

Once there is sufficient data to re-evaluate both discharge and receiving environment water quality, discharge limits, level of sampling and testing frequency may be revised in accordance with an adaptive management approach.

7.1 Objectives

The objectives of the ARD and ML compliance, mitigation, monitoring and reporting program are to:

- Clarify the various compliance requirements related to ARD and ML;
- Ensure that contact runoff water from RSEM sites always meets end-of-pipe criteria in Table 2;
- Ensure that RSEM sites do not negatively affect groundwater;
- Ensure that contact runoff water from RSEM sites is not acutely toxic to aquatic life at the point of discharge;

- Ensure that after allowing for mixing with the Peace River (See Section 7.3) that *in situ* water quality in the Peace River meets BC Water Quality Objectives
- Ensure that contact runoff water from non-RSEM sites meets BC Water Quality for Aquatic Life guidelines before entering any natural watercourse;
- Clarify reporting requirements for Regulators and the Independent Environmental Monitor;
- Evaluate the effectiveness of implemented ARD–ML mitigation measures at both RSEM sites and non-RSEM sites; and
- Inform any adjustments to the Plan, if required.

7.2 Compliance Requirements

7.2.1 Toxicity

All PAG containing RSEM contact water effluent must be not acutely lethal to aquatic life at the point of discharge into the environment. This will be confirmed through 96 hr LC50 tests conducted on water samples taken from each RSEM effluent prior to discharge (See S7.3.1). These samples will be collected and analyzed by BC Hydro.

7.2.2 RSEM end of pipe water quality

The water quality of each PAG contact RSEM discharge point shall at all times not exceed the limits shown in Table 2.

7.2.3 Peace River water quality downstream of each RSEM

BC Hydro shall retain a QP (see S 6.1.1) to define and approve an upstream background sample point, the Initial Dilution Zone (IDZ) sample point (location, distance offshore and sample depth) 100 m downstream of each PAG containing RSEM, and a far-field sample point downstream of all RSEMs where effluent is 100% mixed with the Peace River. This QP will also confirm that the Peace River samples are in fact sampling within the discharge plume area and, confirm discharge plume dynamics under a range of river flows and discharge rates in order to confirm plume modeling predictions. Water quality at these downstream IDZ sample points shall meet the limits shown in Table 2.

Analysis results are to be sent to the IEM immediately in the event an exceedance is identified in any water samples.

7.2.4 PAG contact RSEM sediment

If the Contractor must remove accumulated sediment from a PAG contact sediment pond, the contractor shall test the sediment for metals and hydrocarbon to ensure it meets the regulated limits for the site where that accumulated sediment will be deposited.

Prior to decommissioning or infilling of the PAG contact sediment pond, the contractor shall test the sediment for metals and hydrocarbon to ensure it meets the regulated limits.

7.2.5 Groundwater below PAG contact RSEMs

The Contractor shall monitor groundwater at R5A and R5B RSEM sites as defined in the Groundwater Monitoring program (S. 7.3.3). If the down gradient well samples at these sites exceed the up-gradient control well samples, BC Hydro must prepare a Groundwater Water Quality Mitigation Plan and submit to the satisfaction of the Water Sustainability Act Engineer within 30 days of the exceedance occurring.

Table 2 – PAG containing RSEM end-of-pipe and Peace River water quality limits.

Sediment Pond Parameter	End of Pipe Discharge Limit (mg/L)	Peace River IDZ Limits
Aluminum (dissolved)	0.460	BC WQG ¹
Arsenic (total)	0.050	BC WQG ¹
Cadmium (dissolved)	0.00186	BC WQG ¹
Cobalt (total)	0.55	BC WQG'
Copper (total)	0.0163	BC WQG', or RPD ² of 20% if Peace River > BC WQG ¹
Iron (total)	20.9 (turbid flow period, April – June) 10.3 (clear flow period, July – March)	BC WQG ¹
Manganese (total)	8.29	BC WQG ¹
Zinc (total)	0.251	BC WQG'

Sediment Pond Parameter	End of Pipe Discharge Limit (mg/L)	Peace River IDZ Limits
pH	6.0 to 9.0	BC WQG ¹
All other measured variables	n/a	BC WQG ¹

(1) BC WQG = Approved BC Water Quality Guidelines for Aquatic Life (2016)

(2) RPD = Relative Percent Difference:

$[(\text{Mixed Concentration} - \text{Peace River Concentration}) / \text{Peace River Concentration}] * 100\%$

Where, Mixed Concentration = $[(\text{End of Pipe Concentration} * 1) + (\text{Site Specific Mixing Ratio} * \text{Peace River Concentration})] / (\text{Site Specific Mixing Ratio} + 1)$

An RPD of 20% may be used solely for the Copper IDZ compliance concentration if background Peace River concentration at station Peace-03 is above BC WQG.

7.3 RSEM, Groundwater and Peace River Monitoring

All water quality sampling will follow QA/QC procedures prescribed by the analytical laboratory being used.

7.3.1 Toxicity monitoring

Acute toxicity tests (96-hour LC50 tests using rainbow trout) shall be completed by BC Hydro for water in each PAG containing RSEM sediment pond prior to discharge to the environment (the Contractor shall cooperate with BC Hydro to enable this sampling), in accordance with the following approach:

- Pre-discharge testing:
 - BC Hydro will collect one sample for an acute toxicity test from a representative location indicative of PAG contact water, or from the RSEM contact water at an early stage of sediment pond filling prior to discharge with results completed and reported to the IEM, prior to discharge from an RSEM at the final end-of-pipe discharge point;
- Routine acute toxicity testing:
 - Conducted every two months provided there is sufficient water to collect a sample from the sediment pond without disturbing bottom sediments, whether the pond is discharging or not. A water sample should also be collected concurrently for effluent characterization (as described in s 7.3.2), though the sampling conducted by the Contractor can fulfill this requirement if the sampling timing coincides.
 - In the event of a routine test failure, additional sample(s) will be collected to confirm pond water quality returns to non-toxic conditions immediately following receipt of the failed test results, and every 96 hours thereafter until a sample passes, at which point the testing frequency will resume at a bi-monthly frequency from the date of the passed test.
- Targeted acute toxicity testing:
 - Conducted if sediment pond pH (as measured *in situ* by the Contractor) drops below 6.5 for more than one hour, collected as soon as possible after the poorest water quality condition (e.g., lowest pH), and no later than 24 hours after the poorest water quality condition. A water sample should also be collected

concurrently for effluent characterization (as described in s 7.3.2), though the sampling conducted by the Contractor can fulfill this requirement if the sampling timing coincides.

- Once the pH in the sediment pond has increased to within the acceptable range (defined by the discharge limits), or the rate of change of pH units has stabilized (i.e., less than -0.5 pH units/3-hour period) for 96 hours, a second sample will be collected to confirm water quality has returned to non-toxic conditions.
- Sediment pond water samples must be representative of the water to be discharged

The targeted sampling will be integrated with the sampling conducted under the routine monitoring program to avoid duplication of sampling effort between the two programs (i.e., if a sample is collected for targeted monitoring, it meets the requirement for a bi-monthly sample under the routine monitoring program).

7.3.2 PAG containing RSEM material and contact water monitoring

The Contractor shall install, maintain and operate data loggers to collect hourly measurements of pH, turbidity and electrical conductivity in each PAG-contact water sediment pond. This data will be downloaded and reviewed on a daily basis.

The Contractor shall install a device to continually monitor discharge flow from each RSEM sediment pond discharge pipe. This data shall be downloaded and reviewed on a weekly basis and used to calculate of metal loading to the Peace River which shall be included in the Contractor's weekly reporting.

In addition to the above data logger sampling, the Contractor shall establish and implement a program to monitor the water quality in PAG containing RSEM sediment ponds according to the BC Field Sampling Manual (2013). PAG contact water shall be sampled for the variables in the below list. The sampling program shall occur weekly (on or close to the same day of the week) for each RSEM (when there is sufficient water in the pond and/or when not frozen) and shall address the following requirements:

- The variables that shall be sampled include: total and dissolved metals, pH, TSS, turbidity, sulphate, nitrates, conductivity, temperature, conductivity and hardness. Where it is a risk of, or a known spill event in the RSEM and its catchment, the contractor shall also sample for hydrocarbons in either the water column and/or pond sediments;
- Collection of data at an appropriate interval, sufficient to document changes due to weather events, construction activities, seasonal variability, following adverse events (e.g., spill), etc.;
- Identify a process for alerting BC Hydro and the Independent Environmental Monitor (IEM) where exceedances are identified; and,
- Analysis results are to be sent to the IEM immediately in the event that an exceedance is identified in any sediment pond measurements. Water quality and surface pH results are to be summarized weekly along with contractor's reports,

including daily minimum, mean and maximum data summaries. Reports are to also identify locations or periods of time where sampling was not conducted (e.g., dry pond, frozen conditions, etc.).

The Contractor shall retain a QP(ARD) who will review the above monitoring results at a minimum of a weekly basis for the first 6 months of PAG placement in an RSEM, bi-weekly for the next 6 months then monthly thereafter. The QP(ARD) can revise this frequency if exceedances are observed.

The Contractor shall determine the PAG containing RSEM specific turbidity and total suspended solids (TSS) relationships so that in-situ turbidity measurements can predict real-time TSS concentrations. The turbidity and TSS relationships shall be re-evaluated quarterly for each RSEM.

7.3.3 RSEM 5a and 5b groundwater monitoring

The Contractor shall install groundwater monitoring wells at locations and as per specifications defined by BC Hydro (1 up gradient and 3 down gradient locations). These wells will be designed so they achieve a sufficient depth and appropriate locations to characterize such seepage to groundwater from RSEM area R5a and R5b. The contractor shall install the groundwater wells sufficiently in advance of PAG materials placement to define a groundwater water quality baseline.

Once each well is installed, the contractor shall sample groundwater from each well on a quarterly basis. The variables listed in S 7.3.2 shall be analyzed. Analysis results are to be sent to the IEM immediately in the event that a down gradient sample exceeds up gradient well sample results for any RSEM. Routine results are to be summarized and provided to the IEM within 30 days of the end of each quarter.

7.3.4 Peace River water quality monitoring

BC Hydro (or potentially the contractor) shall establish and implement a program to monitor water quality in the Peace River at an upstream control point, at the IDZ for each PAG containing RSEM 100 m downstream of the sediment pond outlet (see S. 7.2.3), and at a far-field location downstream of all RSEM discharges where the Peace River and RSEM discharge is completely mixed.

Sampling shall be conducted monthly with five samples within a thirty-day period (5- in 30 samples) collected during periods of high (spring freshet) and low (summer/fall) flows.

In the event toxicity test sampling is triggered under the targeted monitoring program (see s 7.3.1), additional IDZ sampling will be conducted where safe/feasible to support a holistic understanding of the event.

Monitoring will not occur during unsafe conditions or if there is no RSEM effluent to monitor.

7.4 Mitigation

7.4.1 PAG Containing RSEM pond mitigation

Sediment ponds will be designed and operated as per the Contract and as per Technical Guidance 7 Environmental Management Act -Assessing the Design, Size, and Operation of Sediment Ponds Used in Mining - Version 1.0, dated December 2015, prepared by Ministry of Environment.

If the Contractor intends to utilize settling aids such as flocculants or coagulants, the specifications as outlined in Appendix I of the CEMP [Erosion and Sediment Control Plan] must be followed.

7.4.2 Exceedance Response Plan

The Contractor shall retain a QP(ARD) who will review the RSEM pond monitoring results and the Peace River monitoring results on a weekly basis for the first 6 months of PAG placement in an RSEM, bi-weekly for the next 6 months then monthly thereafter. The QP(ARD) can revise this frequency if exceedances are observed. This QP(ARD) shall advise the Contractor, in writing, of the effectiveness of PAG material placement mitigation, the effectiveness of sediment pond operation, the need for contingency measures to treat PAG contact water within any sediment pond in a timely fashion so as to prevent end of pipe exceedances (S. 7.2.2) and exceedances in the Peace River (S. 7.2.3), and, as required, when to implement and how to operate/modify water treatment facilities at any PAG contact RSEM necessary to prevent these exceedances.

The QP(ARD) shall recommend additional mitigative measures to be applied at an RSEM in the event that Peace River monitoring records an on-compliance. The QP(ARD) shall document all these reviews and recommendations. The Contractor shall implement the measures prescribed by the QP(ARD) after following the change procedures outlined in the Contract.

7.5 Reporting

BC Hydro's and Contractor's reporting is defined in this Plan and the CEMP. Additionally, during construction, BC Hydro's annual summary reports will be submitted by June 1st and will summarize the results of the testing conducted during the previous year. These reports will be submitted to:

- BC Environmental Assessment Office
- BC Ministry of Environment
- BC Ministry of Forests
- Impact Assessment Agency of Canada
- Natural Resources Canada
- Environment Canada

- City of Fort St John
- District of Hudson's Hope
- District of Taylor
- Peace River Regional District
- Indigenous Nations

7.5.1 RSEM 5a and 5b groundwater monitoring

Analysis results are to be sent to the IEM immediately in the event that an exceedance is identified in any water samples. Routine results are to be summarized and provided to the IEM within 30 days of the end of each quarter.

7.5.2 RSEM PAG material and contact water monitoring

Analysis results are to be sent to the IEM immediately in the event an exceedance is identified in any water samples associated with a discharge to the Peace River. Routine results are to be summarized weekly along with contractor's reports, including daily minimum, mean and maximum data summaries. Reports are to also identify locations or periods of time where sampling was not conducted (e.g. dry pond).

The Contractor shall include in its weekly reports any recommendations from the QP(ARD) for new or changes to existing RSEM management.

7.5.3 Peace River monitoring

BC Hydro will submit to Regulators and the IEM a quarterly summary of Peace River water quality monitoring. Analysis results are to be sent to the IEM immediately in the event an exceedance is identified in any water samples.

8.0 Qualified Environmental Professionals

- Version 4 of The Acid Rock Drainage and Metal Leachate Management Plan was prepared by the following Qualified Environmental Professionals: Sarah Simon, E.I.T., Klohn Crippen Berger Ltd. Harvey McLeod, P. Eng., Klohn Crippen Berger Ltd. Keith Mountjoy, P. Geo., Klohn Crippen Berger Ltd. Vivian Ferrera, M. Sc., Klohn Crippen Berger Ltd.
- Version 5 was modified by Greg Scarborough, R.P.Bio.
- Version 5.3 was modified by Lara Reggin, P. Geo., Tetra Tech Canada Ltd., James Barr, P.Geo., Tetra Tech Canada Ltd., and Molly Brewis, P.Chem., BC Hydro
- Version 6.0 was modified by Molly Brewis, P.Chem., BC Hydro
- Version 6.1 was modified by Greg Scarborough, R.P. Bio.

9.0 References

British Columbia, Ministry of Employment and Investment. (1997). *DRAFT Guidelines and Recommended Methods for the Prediction of Metal Leaching and Acid Rock Drainage at Minesites*. April 1997.

British Columbia, Ministry of Energy and Mines. (1998). *Guidelines for Metal Leaching and Acid Rock Drainage at Minesites*. August 1998.

British Columbia, Ministry of Energy and Mines and Ministry of Environment, Lands and Parks. (1998). *Policy for Metal Leaching and Acid Rock Drainage at Minesites*. July 1998.

British Columbia, Ministry of Environment. (2011). *Environmental Protection Division: Water Quality Guidelines*. Available at: http://www.env.gov.bc.ca/wat/wq/wq_guidelines.html. Accessed: December 2014.

British Columbia Field Sampling Manual, 2013 edition, prepared by Ministry of Environment (formerly Ministry of Water, Land and Air Protection). Available at: <http://www2.gov.bc.ca/gov/content/environment/research-monitoring-reporting/monitoring/sampling-methods-quality-assurance/bc-field-sampling-manual>

International Network for Acid Prevention (INAP). (2012). *The Global Acid Rock Drainage Guide*. Available at: http://www.gardguide.com/index.php/Main_Page. Accessed: December 2012.

Klohn Crippen Berger Ltd.(KCB) and SNC-Lavalin Inc. (SLI) (2011) *Site C Clean Energy Project. Optimization of Project Layout and Configuration of Structures, Geochemistry Reporting for Acid Rock Drainage and Metal Leaching*. March, 2011.

Klohn Crippen Berger Ltd.(KCB) and SNC-Lavalin Inc. (SLI) (2013) *Site C Clean Energy Project. Definition Design, Dam Site Geochemical Characterization – Status at the end of 2012*. January 2013.

Klohn Crippen Berger Ltd.(KCB) and SNC-Lavalin Inc. (SLI) (2014a) *Site C Clean Energy Project. Definition Design, Dam Site Geochemical Characterization – Status at the end of 2013*. March 2014 (DRAFT).

Klohn Crippen Berger Ltd.(KCB) and SNC-Lavalin Inc. (SLI) (2014b) *Site C Clean Energy Project. Definition Design, Cut and Fill from Road Alignments, Borrow Material Sources and Riverbed Sand and Gravel Baseline: Geochemical Characterization – Status at the end of 2013*. March 2014 (DRAFT).

Klohn Crippen Berger Ltd.(KCB) and SNC-Lavalin Inc. (SLI) (2014c) *Site C Clean Energy Project. Definition Design, West Pine Quarry: Geochemical Characterization – Status at the end of 2013*. April 2014 (DRAFT).

Mine Environment Neutral Drainage (MEND). (2009). *Prediction Manual for Drainage Chemistry from Sulphidic Geologic Materials, Report 1.20.1*. December 2009.

Mine Environment Neutral Drainage (MEND). (2005). *List of Potential Information Requirements in Metal Leaching/Acid Rock Drainage Assessment and Mitigation, Report 5.10E*. January 2005.

Minister of Justice, 2012. *Metal Mining Effluent Regulation*. March 2012

MOTI, (2013) Technical Circular T-04/13 on *Evaluating the Potential for Acid Rock Drainage and Metal Leaching at Quarries, Rock Cut Sites and from Stockpiled Rock or Talus Materials used by the MOTI*. September 15, 2013.

Raudsepp, M., Pani, E., and Lai, J. 2010. Quantitative Phase Analysis of Nine Powder Samples using the Rietveld Method and X-Ray Diffraction Data. SGS Canada Inc. Project #:1005 BC Hydro Site C ARD Test Program. February 2010.

Quigley, R.M. 1982. Mineralogical analyses, Peace River, Damsite C, British Columbia. Report to BC Hydro, February 1982.

Technical Guidance 7 Environmental Management Act -Assessing the Design, Size, and Operation of Sediment Ponds Used in Mining - Version 1.0, dated December 2015, prepared by Ministry of Environment.

Tetra Tech (2020a), Preliminary ARD-ML Classification for Bedrock Material at the Halfway River Bridge Construction Project, Highway 29 Re-Alignment, Technical Memo February 2020 (Draft).

Tetra Tech (2020b), Preliminary ARD-ML Classification for Bedrock Material at the Dry Creek Construction Project, Highway 29 Re-Alignment, Technical Memo March 2020.

Tetra Tech (2020c), Preliminary ARD-ML Classification for Bedrock Material at the Cache Creek and Bear Flats Bridge and Highway Realignment Construction Area, Highway 29 Re-Alignment, Technical Memo April 2020.

Tetra Tech (2020d), Preliminary ARD-ML Classification for Bedrock Material at the Farrell Creek Bridge and Highway Realignment Construction Area, Highway 29 Re-Alignment – Rev 01, Technical Memo April 2020.

Tetra Tech (2020e), Preliminary ARD-ML Classification for Bedrock Material at the Lynx Creek Construction Project, Highway 29 Re-Alignment – Rev 01, Technical Memo June 2020.

Appendix F Water Licence Leaves to Commence Construction Process

Appendix F

Water Licence Leaves to Commence Construction Process

Site C Clean Energy Project

Revision 1: March 31, 2016

Table of Contents

Revision History	2
1.0 Introduction	3
2.0 Regulation of Works	3
3.0 Project Description	4
4.0 LCC Submittals	5
5.0 Timelines	5

Revision History

Version	Date	Comments
Rev 0	03-24-2016	Final Document
Rev 1	03-31-2016	Final Document

1.0 Introduction

On February 26, 2016, the Comptroller of Water Rights (CWR) issued to BC Hydro Conditional Water Licence 132990, authorizing the diversion and use of water, and Conditional Water Licence 132991, for storage of water, for the Site C Clean Energy Project (the Project). Water Licence 132990 authorizes the construction and operation of an approach channel, intake, dam, spillways, powerhouse and tailrace, access road, and ancillary works associated with the dam and generating station. Water Licence 132991 authorizes the construction and operation of a dam, spillways, reservoir, shoreline protection berm at Hudson's Hope, and ancillary works associated with the operation of the dam.

The licences set out the conditions under which the named components of the water licences can be constructed and operated. The licences also require BC Hydro to retain both an Independent Engineer, who will provide services to the Engineer of the CWR (the Engineer) under the *Water Sustainability Act*, and an Independent Environmental Monitor, who will monitor environmental impacts from the construction of these works.

The purpose of this document is to provide an overview of the regulation of works under the water licences, the process for obtaining Leaves to Commence Construction (LCCs), the roles and responsibilities of BC Hydro, the IEM and IE in the LCC process, and the delivery of submittals. Detailed information these subjects is provided within the water licences themselves and the applicable LCCs.

2.0 Regulation of Works

The Engineer has the power to regulate the construction of works, including:

- 1) The criteria for the design and construction of works to protect the public and the environment.
- 2) The criteria for the operation of the works to protect the interests of licensees, riparian owners and owners of land adjacent to the works, and protect the environment from adverse effects.
- 3) The construction activities that may adversely affect the public, the environment and the interests of licensees, riparian owners and owners of land adjacent to the works.

The Engineer has the authority to direct BC Hydro to change the manner in which the works are being constructed should she/he determine works are hazardous to the public and the environment, or that the interests of licensees, riparian owners and owners of land adjacent to the works may be adversely affected.

The licences require that BC Hydro obtain LCCs from the Engineer, in writing, prior to commencing construction of each component of works authorized under the licenses. In addition, before undertaking construction of any component of works for which a LCC has been issued under section (j) 5) of the licences, the licensee must obtain a letter from the Independent Engineer that the actual construction of that component work may proceed (Section (k)(3) of the licences).

Attachment A of the licences (Scope of Information and Reports by the Independent Engineer) and Attachment B of the licences (Scope of Information and Reports by the Independent Environmental Monitor) describe the role and responsibilities of the IE and the IEM, respectively, in relation to the Engineer and the issuance of LCCs. The IE is responsible for reviewing submissions from BC Hydro for the LCCs. The IE must prepare a recommendation report for the Engineer on the issuance of LCCs based on the review of materials.

The IEM is responsible for reviewing the CEMP, including Environmental Protection Plans (EPPs) and Environmental Works Plans (EWPs) for work components conducted under the water licences, and verifying that the plans adequately address the potential environmental impacts before construction work can proceed. The IEM will make recommendations to the Engineer on the adequacy of the CEMP and to the IE on the adequacy of the EPPs and EWPs before Leaves are granted. The IEM's delegates have the same authority as the IEM.

3.0 Project Description

A description of the Project and its components is provided in the Project Description submitted as part of the Site C Clean Energy Project Environmental Assessment in Section 4.3 and 4.5 of the Environmental Impact Statement (EIS) process, available at

http://www.ceaa-acee.gc.ca/050/documents_staticpost/63919/85328/Vol1_Introduction_etc.pdf

The following Project components associated with dam and reservoir construction are subject to the Provincial Water Licensing Process and require LCCs:

- Initial Works (Historic Drill Hole and Adit Backfills, Left Bank Excavation, right Bank Side channel Dikes, Right Bank Drainage Tunnel, Moberly Bridge Construction)
- Relocated Excavated Surplus Material Sites (RSEMs)
- Right Bank Stage 1 Cofferdam and Excavations
- Reservoir Clearing
- Left Bank Stage 1 Cofferdam and Diversion Works
- RCC Structures
- Stage 2 Cofferdams and Earthfill Dam
- Generating Station and Spillway
- Approach Channel Stage 2
- Reservoir Clearing
- Hudson's Hope Berm
- Diversion Tunnel Conversion and Reservoir Filling
- Operations: 6 Units on line
- Ancillary Works associated with Operation of the Dam and Generating Station

The construction of a permanent access road, River Road, was constructed under a *Water Act* Section 9 permit as part of site preparation activities. Operation and maintenance of the road is covered under Water Licence 132990.

4.0 LCC Submittals

Before commencing construction of the Works authorized by the licences, BC Hydro must submit general information on the Project to the CWR and the IE for review and approval, including, but not limited to:

- Plans that show the general arrangement of the works
- Criteria for the design of the works
- Criteria for the operation of the works
- Schedule for the construction of the works
- Construction Environmental Management Plan (CEMP) for the management and mitigation of construction impacts

The water licences also require that the IE be satisfied that BC Hydro has completed all monitoring, mitigation and compensation projects required for each LCC. The IE will require that the IEM is satisfied that the monitoring, mitigation and compensation plans meet their intended requirements, that conditions have been met, and that the IEM has reviewed and accepted Environmental Protection Plans. The IE must also summarize for the Engineer any outstanding matters that would make the works a hazard to the public and the environment.

5.0 Timelines

BC Hydro will submit required documents to both the IEM and IE as soon as they are available, and allow for sufficient time for review in accordance with the construction schedule. The construction schedule and associated updates will be provided to the IEM and IE in managing the timing of LCC Submissions. BC Hydro will strive to provide the Engineer with a minimum of one month for LCC review.

Both the IE and IEM will review documents as they become available to endeavor to meet the timelines identified by the schedule. The IE and the IEM will communicate with each other during the construction of the works to coordinate their activities and to provide information to the Engineer for proper regulation of the construction of the works.

Appendix G Mitigation, Management and Monitoring Plans

Appendix G

Mitigation, Management and Monitoring Plans

Site C Clean Energy Project

Revision 0: March 24, 2016

Table of Contents

Revision History	2
1.0 Introduction	3
2.0 Mitigation, Monitoring and Management Plans	3
2.1 Aboriginal Plant Use Mitigation Plan	3
2.2 Aboriginal Training and Inclusion Plan.....	3
2.3 Accidents and Malfunctions Plan.....	3
2.4 Agricultural Monitoring and Follow-up Program.....	4
2.5 Business Participation Plan	5
2.6 Cultural Resources Mitigation Plan.....	5
2.7 Construction Safety Management Plan	5
2.8 Emergency Services Plan	6
2.9 Fisheries and Aquatic Habitat Management Plan	6
2.10 Fisheries and Aquatic Habitat Monitoring and Follow-up Program	6
2.11 Health Care Services Plan	7
2.12 Heritage Resources Management Plan	7
2.13 Housing Plan and Housing Monitoring and Follow-up Program	7
2.14 Labour and Training Plan	7
2.15 Recreation Program	8
2.16 Vegetation Clearing and Debris Management Plan.....	8
2.17 Vegetation and Wildlife Mitigation and Monitoring Plan	9
2.18 Quarry Development Plans.....	10
2.18.1 Del Rio Pit Development Plan	10
2.18.2 West Pine Quarry Development Plan	10
2.18.3 Wuthrich Quarry Development Plan	10
2.18.4 West Pine Quarry Development Plan	11
2.18.5 Impervious Core Materials Source Development Plan.....	11
2.19 Acid Rock Drainage Metal Leachate Management Plan.....	11

Revision History

Version	Date	Comments
Rev 0	03-24-2016	Final Document

1.0 Introduction

The Environmental Requirements for the Site C Clean Energy Project (The Project) include conditions of the Environmental Assessment Certificate for the Project and the conditions of the Decision Statement issued by the Minister of Environment of Canada. Condition 70 of the EAC Document required BC Hydro to prepare mitigation, management and monitoring plans (“Plans”) to satisfy specified conditions.

The purpose of this document is to provide a high level overview of the plans as they pertain to construction and provide links to where the plans can be viewed. Direct references between these Plans and the CEMP are identified in the descriptions below where applicable. BC Hydro will provide clear direction to its contractors to identify relevant information and requirements from these Plans where applicable to their work.

2.0 Mitigation, Monitoring and Management Plans

The following subsections provide overview level summaries of applicable Mitigation, Management and Monitoring Plans that are available at www.sitecproject.com (accessed March 18, 2016).

2.1 Aboriginal Plant Use Mitigation Plan

The purpose of the Aboriginal Plant Use Mitigation Plan (the “Plan”) is to describe the mitigation measures intended to avoid or reduce the loss or destruction of plants currently harvested by Aboriginal groups within the Project activity zone, and to describe compensation measures. This Plan has been developed in accordance with Conditions 25 and 26 of the Environmental Assessment Certificate (EAC) and Condition 14 of the federal Decision Statement (FDS).

This plan describes the Ground-Truthing Program, as well as the approach to identification of opportunities for plant relocation, ecological community restoration and supply of plants from a local indigenous plant nursery.

The relevant areas of this plan to construction activities governed by the CEMP are identified in the CEMP as follows: Soil Management, Site Restoration and Revegetation Plan (local sourcing of indigenous plants), Air Quality Monitoring Program (identification of sensitive receptors), Smoke Management Plan (identification smoke sensitivity zones).

2.2 Aboriginal Training and Inclusion Plan

The Aboriginal Training and Inclusion Plan (Plan) describes how BC Hydro will implement the mitigation measures directed toward Aboriginal groups pursuant to sections 17 (Labour Market), 18 (Regional Economic Development), and 28 (Population and Demographics) of the EIS. As monitoring is not a component of these mitigations, no monitoring is included in this Plan. This Plan is aligned with the Labour and Training Plan, and the Business Participation Plan. The Plan has been developed in accordance with Condition 54 of the Environmental Assessment Certificate (EAC).

There are no relevant aspects of this plan to construction activities governed by the CEMP.

2.3 Accidents and Malfunctions Plan

The objective of the Accidents and Malfunctions Plan is to identify potential accidents and malfunctions associated with construction of the Project that may result in adverse environmental effects. The Plan builds on information that was provided in Section 37.2 of the Project’s Environmental Impact Statement (EIS), which described:

- the likelihood and circumstances under which those accidents or malfunctions could occur;
- an overview of the measures that would be implemented to reduce the likelihood accidents and malfunctions occur, and those that could be implemented to mitigate the potential occurrence of an accident or malfunction; and
- the potential effects of accidents and malfunctions.

The Accidents and Malfunctions Plan has been developed in accordance with Condition 2 of the federal Decision Statement.

The relevant areas of this plan to construction activities governed by the CEMP are as follows:

Plan Area	CEMP Cross-Reference Areas
failure of the Stage 2 Upstream Cofferdam	S. 4.10 Ice Management CSMP Emergency Response Plan
Release or spills of chemicals and hazardous materials	s. 4.13 Spill Prevention and Response s. 4.6 Fuel Handling and Storage Management s. 4.8 Hazardous Waste Management CSMP Emergency Response Plan
Containment pond leakage or failure	s. 4.4 Erosion Prevention and Sediment Control Management; s. 4.13 Spill Prevention and Response; and s. 4.14 Surface Water Quality Management CSMP Emergency Response Plan
Sediment control failure; and	s. 4.4 Erosion Prevention and Sediment Control Management; s. 4.14 Surface Water Quality Management CSMP Emergency Response Plan
Fire and explosion.	s. 4.2 Blasting Management; and CSMP Fire Hazard and Abatement Plan

2.4 Agricultural Monitoring and Follow-up Program

The agricultural monitoring and follow-up programs were proposed by BC Hydro in Section 20.7 of the EIS (July 2013) where the creation of the reservoir may result in site-specific changes that may affect agricultural operations on individual farm operations, and where project effects on agricultural operations are not already addressed under agreements with BC Hydro. The agricultural monitoring and follow-up programs were included in the Site C Environmental Assessment Certificate as Condition #31. The monitoring program results are to confirm if a Project change has occurred, and to specify the adverse effect on agricultural operations.

Monitoring programs to determine if creation of the Site C reservoir may result in site-specific changes that may affect agricultural operations include the following:

- Reservoir induced effects on crop drying;
- Effects on crop production due to changes in groundwater elevations;
- Effects on agriculture due to changes in wildlife habitat utilization; and
- Climate parameters to estimate irrigation water requirements near the reservoir.

There are no relevant aspects of this plan to construction activities governed by the CEMP.

2.5 Business Participation Plan

The objective of the Business Participation Plan is to describe the information and notification program that will keep businesses informed and updated on the opportunities associated with the construction of the Project. The Business Participation Plan builds on BC Hydro's Business Liaison Program, which was established to (a) keep the business community updated on the status of the Project and (b) inform and engage local, regional and Aboriginal companies on future Site C Project opportunities (see Section 9.1.2.2.5 of the Environmental Impact Statement for details). The Business Participation Plan has been developed in accordance with Conditions 51 and 72 and a portion of 54 of the Environmental Assessment Conditions (EAC).

The relevant areas of this plan to construction activities governed by the CEMP are cross-referenced in Appendix C. Construction Communication Plan, and Appendix D. First Nations Communication Plan.

2.6 Cultural Resources Mitigation Plan

The objective of the Cultural Resources Mitigation Plan (the "Plan") is to describe and implement the measures listed below to reduce impacts on, or provide support to, matters of cultural importance to local Aboriginal Groups. The Plan has been developed in accordance with Condition 63 of the Environmental Assessment Certificate. In accordance with this Plan, BC Hydro established the Culture and Heritage Resources Committee with a first meeting in July 2015, and has met regularly with this committee since this date.

There are no relevant aspects of this plan to construction activities governed by the CEMP.

2.7 Construction Safety Management Plan

The Construction Safety Management Plan (CSMP) provides guidance to all BC Hydro employees and contractors on the safety management requirements for construction of the Project. The CSMP provides performance-based safety requirements for the Project and provides contractors the basis for the development of Contractor Site Safety Management Plans (CSSMPs) prior to the commencement of construction activities. The CSMP applies to all construction activities undertaken as part of the Project. The CSMP is the foundational document within the Project Safety Management Program, and is aligned with Section 35 of the Environmental Impact Statement (EIS). Safety inspections and auditing will be performed throughout the construction period to monitor, evaluate, and report on the effectiveness of the CSMP and associated plans and procedures.

The relevant sections of the CSMP to construction activities governed by the CEMP include:

- Emergency Response
- Fire Hazard and Abatement Plan
- Public Safety Management Plan
- Traffic Management Plan
- Worker Health and Safety Management Plan

The Traffic Management Plan includes the following measures that will protect wildlife, maximize worker and public safety, and manage effects on productivity – in summary these include maximizing the use of existing corridors, use of VHF /UHF communication radios, control or restriction of access as appropriate, identification of access roads to be decommissioned after Project use, and public safety measures.

2.8 Emergency Services Plan

The objective of the Emergency Services Plan is to describe the mitigation measures that will address the potential effects of the Project on emergency services that may occur either directly through Project use of services, or indirectly through an increase in the local residential population and their related demand for services as resident (see Section 30 of the EIS for details). The plan includes baseline information and/or mitigation measures for areas assessed in the EIS: the City of Dawson Creek, the City of Fort St. John, the District of Chetwynd, the District of Hudson’s Hope, the District of Taylor, and the Peace River Regional District. Emergency services provided by the RCMP and the BC Ambulance Service are also considered in the plan. The Plan has been prepared in accordance with Condition 43 of the Environmental Assessment Certificate.

The relevant sections of this plan to construction activities governed by the CEMP are fire service provision (BC Wildfire Management) and the BC Conservation Officer Service (enforcement of human-wildlife conflict prevention and response).

2.9 Fisheries and Aquatic Habitat Management Plan

The objective of the Fisheries and Aquatic Habitat Management Plan (FAHMP) is to describe the measures that will be used to mitigate the adverse effects of the Project on fish and fish habitat during the construction and operation phases. The plan has been developed in accordance with Condition #4 of the Environmental Assessment Certificate (EAC) and Conditions 8.1 – 8.10 (and sub-conditions) of the Federal Decision Statement (FDS). FDS conditions 8.3 to 8.7 refer to “a fish and fish habitat management plan”, while the EAC condition 4 refers to “a Fisheries and Aquatic Habitat Management Plan”. Each refers to similar requirements for fish. For simplicity, BC Hydro developed one plan, entitled “Fisheries and Aquatic Habitat Management Plan.” The overarching objective of the Plan as outlined by EAC Condition 4 is to manage harmful Project effects on fish and fish habitats during the construction and operation phases by implementing mitigation measures detailed in a Fisheries and Aquatic Habitat Management Plan.

The relevant sections of the Plan to construction activities governed by the CEMP are identified in Section 6.1 of this Plan, which identify the specific requirements of the EAC and FDS that are addressed in the CEMP Section 4.4 Erosion Prevention and Sediment Control Management and Section 4.5 Fisheries and Aquatic Habitat Management.

2.10 Fisheries and Aquatic Habitat Monitoring and Follow-up Program

The objective and scope of the Fisheries and Aquatic Habitat Monitoring and Follow-up Program (FAHMFP) is to set out the monitoring and procedures that will be implemented as required by Condition 7 of the EAC. The overarching objective of the Fisheries and Aquatic Habitat Monitoring and Follow-up Program is to assess the effectiveness of measures to mitigate Project effects on healthy fish populations in the Peace River and tributaries, and, if recommended by a QEP or FLNR, to assess the need to adjust those measures to adequately mitigate the Project’s effects.

There are no relevant aspects of this plan to construction activities governed by the CEMP.

2.11 Health Care Services Plan

The objective of the Health Care Services Plan is to describe the measures that will be used to deliver on-site health care for the Project workforce, to coordinate health program delivery with NHA, and to provide healthcare service information to new resident workers and their families. The scope of the Health Care Services Plan is developed in accordance with Condition 42 of the Environmental Assessment Certificate. The key measure in this plan is the operation of an on-site health clinic during Project construction, in addition to standard requirements for industrial first aid services in work areas.

There are no relevant aspects of this plan to construction activities governed by the CEMP.

2.12 Heritage Resources Management Plan

The purpose of the Heritage Resources Management Plan is to describe the measures that will be used to mitigate the adverse effects of the Project on heritage resources. The Plan has been developed in accordance with the conditions of the Environmental Assessment Certificate (EAC) and federal Decision Statement (FDS).

The requirement to develop this plan is described in the CEMP in Section 4.9 Heritage Resources Management.

2.13 Housing Plan and Housing Monitoring and Follow-up Program

The objective of the Housing Plan and Housing Monitoring and Follow-up Program is to describe the measures that will be used to mitigate the adverse effects of the Project on changes in the demand for housing, as well as the monitoring of market changes that may require additional mitigation. This plan has been prepared in accordance with Conditions 48 and 49 of the Environmental Assessment Certificate (EAC).

There are no relevant aspects of this plan to construction activities governed by the CEMP.

2.14 Labour and Training Plan

The purpose of the Labour and Training Plan is to describe the measures that will be implemented to support local labour force capacity and availability for employment during the construction of the Project (see Section 17 of the EIS for the effects assessment on the Labour Market).

The Labour and Training Plan includes measures for Aboriginal groups, with additional targeted mitigation measures described in the Aboriginal Training and Inclusion Plan. The First Nations with communities situated within the boundaries of the LAA include the Doig River First Nation, Halfway River First Nation, Prophet River First Nation, West Moberly First Nations, Blueberry First Nation, Sauteau First Nations, and Fort Nelson First Nation. The First Nations communities in the regional assessment area include the First Nations communities in the local assessment area plus the McLeod Lake Indian Band.

The Labour and Training Plan has been developed in accordance with Conditions 44 and 53 of the Environmental Assessment Certificate (EAC).

There are no relevant aspects of this plan to construction activities governed by the CEMP.

2.15 Recreation Program

The purpose of this Recreation Program is to describe a) recreation programs and services to be offered for Project workers at the worker camp, and b) recreation programs and services to be offered for Project workers off-site, in coordination with the City of Fort St. John. This Recreation Program has been developed and must be implemented in accordance with Condition 55 of the Environmental Assessment Certificate. This plan includes measures for camp recreational programs and services, as well as measures agreed to by the City of Fort St. John with respect to regional recreation programs and services.

There are no relevant aspects of this plan to construction activities governed by the CEMP.

2.16 Vegetation Clearing and Debris Management Plan

The objective of the Vegetation Clearing and Debris Management Plan is to provide an overview of clearing activities for the Project. The Plan was initially provided in the EIS, as Appendix A of Volume 1. The Plan has since been revised and developed in accordance with Conditions 13 and 17 of the Environmental Assessment Certificate. This plan describes the areas within the Project Activity Zone as six areas requiring varying degrees of vegetation removal, as follows:

- Dam site
- Quarries
- Highway 29 Realignment areas
- Access Roads (four categories including new and existing access roads, and water crossings)
- Transmission Corridor
- Reservoir

Within each category clearing requirements and approaches are specified to meet the needs of the Project (for example the extent of clearing, and if required grubbing and stripping) and to specify measures to comply with project-specific conditions and other applicable regulatory requirements, industry standards or guidance documents to be followed. These include environmental specifications and cross-references to the relevant requirements of this CEMP with respect to clearing activities and access roads.

BC Hydro and/or its Contractors will submit the appropriate permit applications for clearing activities to regulatory agencies. Those applications are consistent with the information provided in the Vegetation Clearing and Debris Management Plan, and the CEMP, but will provide site specific information and detail relevant to each permit area.

The VCDMP states that the CEMP applies to all clearing activities as the basis for the development of their EPPs. For ease of use the VCDMP also references several CEMP sections including:

VCDMP Section	CEMP Section
3.0 Clearing Planning Overview – re clearing only within approved Project Activity Zone and monitoring to ensure	2.0 Environmental Management Roles and Responsibilities – role of QEP
3.5 Environmental Management – re critical bird windows, nest and lek search protocol / buffers where required	4.17 Wildlife Management

<p>7.0 Clearing for Access Roads – re Water Crossings and Instream Works</p> <p>7.3 New Clearing Access Road Approach – re clearing near riparian habitat</p> <p>7.3 New Clearing Access Road Approach – re deactivation of temporary clearing access roads</p> <p>7.3.2 – re deactivation of temporary winter access roads</p> <p>8.2 Transmission Line Corridor Clearing Approach – re clearing within or adjacent to water courses</p> <p>9.1.3 Riparian Areas within the Reservoir – re clearing near waterways, riparian zones</p>	<p>4.5 Fisheries and Aquatic Habitat Management</p>
<p>3.6.2 Non-merchantable wood disposal</p>	<p>CEMP Appendix A Smoke Management Plan</p>

2.17 Vegetation and Wildlife Mitigation and Monitoring Plan

The objective of the Vegetation and Wildlife Mitigation and Monitoring Plan (the Plan) is to describe the mitigation and monitoring measures that will be implemented to meet the requirements of Decision Statement conditions 9, 10, 11, 16 and 18 and Environmental Assessment Certificate conditions 9 to 12, 14 to 16, 19, 21, 23, and 24. These conditions, and where they are addressed in the Vegetation and Wildlife Mitigation and Monitoring Plan, are listed in Tables 1 and 2 below.

The mitigation measures proposed by BC Hydro, and their likely success, were taken into account in the environmental assessment to determine the residual adverse effects of the Project on Vegetation and Ecological Communities and Wildlife Resources (see EIS Sections 13 and 14 on Vegetation and Ecological Communities and Wildlife Resources, respectively). As described in the EIS, the Project’s adverse effect on these valued components will be significant, and mitigation cannot fully address these effects. In cases where the proposed mitigation measures are considered to be uncertain, the predicted effects of the Project on the target species will not exceed the effects predicted in the EIS.

The purpose of the monitoring and follow-up programs is to determine the success of implemented mitigation measures (for example, monitoring the use of mitigation structures by target species). The monitoring results can be used to provide lessons learned and advance the suite of mitigation measures available for the target species for future projects.

The VWMMP identifies, in section 6.2, that all of the vegetation and ecological communities, and wildlife conditions of the EAC and the FDS will be implemented through a) the Construction Environmental Management Plan, b) the Vegetation Clearing and Debris Management Plan, and c) the Vegetation and Wildlife Mitigation and Monitoring Plan. The following EAC conditions relevant to vegetation and

ecological communities, and wildlife resources, are fully addressed in the CEMP and / or the Vegetation Clearing and Debris Management Plan: EAC conditions 8, 9, 13 17, 18, 20, and 22 (for Wildlife Resources) are fully addressed in the CEMP and / or the Vegetation Clearing and Debris Management Plan and not further covered in the VWMMP. The VWMMP, Table 2, identifies the specific aspects of the following conditions that are addressed in the CEMP: Condition 12, 15.

2.18 Quarry Development Plans

The following development plans have been developed to date. Additional development plans will be prepared in advance of construction activities at these sites in accordance with EAC condition 71.

2.18.1 Del Rio Pit Development Plan

Del Rio Pit is an existing gravel reserve operated by the British Columbia Ministry of Transportation and Infrastructure (MOTI) and is located approximately 40 km from the proposed location of the Site C dam. The Project requires approximately 130,000 cubic metres of road fill and borrow, which is unprocessed material removed directly from the deposit, and processed granular aggregates required from Del Rio Pit. This volume of granular material is produced within the existing boundaries of the reserve and the mining can be done by stripping overburden first and subsequently mining the material in one or two benches.

The purpose of this plan is to support permitting requirements, and to guide use of the pit during construction. This plan has been prepared and submitted in accordance with condition 71 of the Environmental Assessment Certificate. The scope of this plan is pit use throughout the life of the Project. The plan has been developed in accordance condition 71 of the Environmental Assessment Certificate.

The development plan states, in s. 4.4, that the contractor will adhere to the environment and safety requirements described in the Construction Environmental Management Plan (CEMP) and the Construction Safety Management Plan (CSMP). The plan also identifies (s. 4.5) site specific management measures, and provides requirements for site reclamation based on stated future land use.

2.18.2 West Pine Quarry Development Plan

The Project requires riprap material for constructing the erosion protection for the temporary construction bridge across the Peace River and for access road construction on the south bank of the Peace River. West Pine Quarry, an existing riprap source operated by MOTI, has been identified as the preferred source of riprap for Year 1 (2015) construction requirements. The quarry is located on the north side of Highway 97 approximately 75km southwest of Chetwynd, BC and 162km south of the proposed Site C project site (via existing and proposed roads) as shown in Figure 1.

The purpose of this plan is to support permitting requirements, and to guide use of the quarry site during construction. The scope of this plan is the first year of quarry use by the Project.

The development plan states, in s. 4.4, that the contractor will adhere to the environment and safety requirements described in the Construction Environmental Management Plan (CEMP) and the Construction Safety Management Plan (CSMP). The plan also identifies (s. 4.5) site specific management measures, and provides requirements for site reclamation based on stated future land use.

2.18.3 Wuthrich Quarry Development Plan

Wuthrich Quarry is located approximately 2 km east of Charlie Lake and approximately 3 km north of the Alaska Highway 97 along 271 Road. It is approximately 6 km northwest of the City of Fort St. John and is approximately 10 km away from the proposed location of the Site C dam. The site location is

shown in Figure 1. The property is currently owned and operated by the British Columbia Ministry of Transportation and Infrastructure (MOTI).

The Project requires approximately 253 000 m³ of riprap and approximately 98 000 m³ of riprap bedding for construction of roads, the temporary construction bridge and dam components. Most of the material will be required in the first four years of the dam construction schedule, with a smaller amount required after reservoir filling has commenced. This volume of material will be produced and stored within the existing boundaries of the quarry.

The objectives of this plan are to support permitting requirements; and to guide use of the quarry site during construction. The scope of this plan is quarry use throughout the life of the Project.

The development plan states, in s. 3.4, that the contractor will adhere to the environment and safety requirements described in the Construction Environmental Management Plan (CEMP) and the Construction Safety Management Plan (CSMP). The plan also identifies (s. 3.5) site specific management measures, and provides requirements for site reclamation based on stated future land use.

2.18.4 West Pine Quarry Development Plan

An additional West Pine Quarry Development Plan will be prepared to address ongoing use for the purposes of dam construction activities beyond the scope of this plan.

2.18.5 Impervious Core Materials Source Development Plan

This plan will be added when complete.

2.19 Acid Rock Drainage Metal Leachate Management Plan

The Acid Rock Drainage Metal Leachate (ARDML) Plan includes risk-based planning and design approaches to quantify the long-term impacts of mitigation option(s) and select the most appropriate mitigation option(s). Mitigation measures include on-going geochemical testing and analysis of materials that will define handling and storing plans to reduce source loading discharges and minimize long-term monitoring and maintenance requirements.

BC Hydro has performed advanced geochemical characterization of materials to identify known or potential sources of acid rock drainage and metal leaching material. BC Hydro will prepare technical specifications as relevant to the work for contractors to adhere to in accordance with the CEMP including the ARDML Plan. Contractors will be required to prepare a work plan for the specific location / work activity covered by the specification, including relevant drawings and specifications, to prepare an Environmental Protection Plan including monitoring and reporting, and adhere to and identify mitigation measures to effectively manage materials so that there is an insignificant change in pH, total metals and dissolved metals upstream and downstream of the dam site as a result of Project construction.

Appendix H Soil Management, Site Restoration and Revegetation Plan

Appendix H

Soil Management, Site Restoration and Revegetation Plan

Site C Clean Energy Project

Revision 3, October 11, 2022

Table of Contents

1.0	Background.....	4
2.0	Objectives.....	6
3.0	Predicted effects on the biological values.....	6
4.0	Soil Management	8
4.1	Broad mitigation objectives.....	8
4.2	Strategies for achieving biological objectives	8
4.3	Tactics for achieving biological objectives	8
4.4	Implementation Schedule	8
4.5	Implementation Methods	8
4.6	Monitoring.....	9
4.7	Reporting and Publication.....	9
5.0	Erosion and Dust Control.....	9
5.1	Broad mitigation objectives.....	9
5.2	Strategies for achieving biological objectives	9
5.3	Tactics for achieving biological objectives	9
5.4	Implementation Schedule	10
5.5	Implementation Methods	10
5.6	Monitoring.....	10
5.7	Reporting and Publication.....	11
5.8	Data Management.....	11
5.9	Relevant Technical Expertise	11
6.0	Site Reclamation and Revegetation	11
6.1	Broad mitigation objectives.....	11
6.2	Biological objectives (for mitigation).....	11
6.3	Strategies for achieving biological objectives	14
6.4	Tactics for achieving biological objectives	14
6.5	Implementation Schedule	16
6.6	Experimental design/Adaptive Management framework	16
6.7	Baseline Data	16
6.8	Implementation Methods	16
6.9	Monitoring.....	16
6.10	Reporting and Publication.....	17
6.11	Data Management.....	17
7.0	Relevant Technical Expertise.....	17
8.0	References.....	17

Revision History

Version	Date	Comments
Rev 0	July 8, 2016	Final Document
Rev 1	February 15, 2019	<ul style="list-style-type: none"> Revised text to allow for the use of non-native seed mixes during initial site revegetation. These modifications are intended to reflect best practice at site and to provide clarity on suitable seed mixes that are need to improve effectiveness of erosion control measures at site while meeting the project's long-term objective of achieving a sustainable native species ecosystem (Section 3.0)
Rev 2	June 5, 2020	<ul style="list-style-type: none"> Removed reference to MCW contract specifications Updated Table 1 Area A reclamation area estimate based on predicted area to be disturbed by aggregate extraction Removed links to other mitigation plans as no longer relevant
Rev 3	October 11, 2022	<ul style="list-style-type: none"> Section 1.0 – added reference to BC Hydro reclamation contracts. Section 6.3 – removed leaf litter as not available locally. Section 6.4 – replaced rough and loose surface with scarified surface and added “as required” regarding woody debris density Section 6.4 – north facing slopes – white spruce forest changed to mixedwood forests (deciduous and coniferous tree species). Also replaced rough and loose surface with scarified surface. Section 6.4 – riparian areas – removed leaf litter as not available locally. Edits to riparian plantings as it will not always possible to install stakes to a depth of 1 m due to soil and bedrock conditions. Also replaced rough and loose surface with scarified surface. Section 6.4: <ul style="list-style-type: none"> Plateau areas – white spruce forest changed to mixedwood forests (deciduous and coniferous tree species). Replaced rough and loose surface with scarified surface. Added text to indicate that reclamation areas will be monitored to confirm vegetation survival and growth. Added text to indicate maintenance requirements will be determined based on monitoring data. Section 6.9 -- Revised monitoring text to reflect that, dependent on contract requirements, monitoring may not be the requirement of the contractor and BC Hydro will be responsible for monitoring. Section 7.0 -- Amended text to reflect that David Poster has retired General formatting updates

1.0 Background

This soil management, site restoration and revegetation plan is intended to restore and revegetate areas disturbed during Project construction and achieve compliance with EAC condition 8. EAC condition 8 requires BC Hydro to:

- *Develop a Soil Management, Site Restoration, and Revegetation Plan to effectively manage disturbed soils, and to reclaim and revegetate disturbed construction areas to a safe and environmentally acceptable condition. The Soil Management, Site Restoration, and Revegetation Plan must be developed by a QEP.*

The Soil Management, Site Restoration, and Revegetation Plan must include at least the following:

- *Soil storage and handling measures that will maximize native soil use in restoration efforts, and manage incidental introduction and spread of invasive species.*
- *Manage run-off so that it is directed around soil stockpiles and areas where excavation, spoil placement, and staging activities occur.*
- *Progressive closure and reclamation of any temporary disturbance. Disturbed sites are replanted within one year with ground cover, shrubs, or trees that are regionally appropriate once erosion concerns have been addressed.*
- *Identify native seed mixes used for site restoration and revegetation purposes.*
- *Identify traditional use plants for revegetation purposes, in consultation with Aboriginal Groups.*

The EAC Holder must develop, implement and adhere to the final Soil Management, Site Restoration, and Revegetation Plan, and any amendments, to the satisfaction of EAO.

Implementation of the Soil Management, Site Restoration and Revegetation Plan will be through the Site C Construction Environmental Management Plan (CEMP), specifications attached to construction contracts and BC Hydro reclamation contracts. The CEMP applies to all activities undertaken in construction of the Project. Contractors are required to develop Environmental Protection Plans (EPPs) in accordance with the CEMP for their specific activities and work areas. These documents indicate how they will implement the requirements of the CEMP while undertaking their work. Contractors EPPs are reviewed by BC Hydro and the Independent Environmental Monitor (IEM). Contractors cannot begin work until these documents are approved by BC Hydro. Once contractors begin working on site environmental monitors and the IEM review the contractor's work site and works to ensure they are occurring in accordance with their EPP and thus the CEMP. Figure 1 illustrates the relationship between the Site Restoration and Revegetation Framework, the CEMP, contractor EPPs and construction contracts.

Contracts may contain detailed specifications instructing how the Site Restoration and Revegetation Framework is to be implemented by the contractor within their work zone.

Figure 1. Relationship between the Site Restoration and Revegetation Framework, the CEMP, contractor EPPs and construction contracts

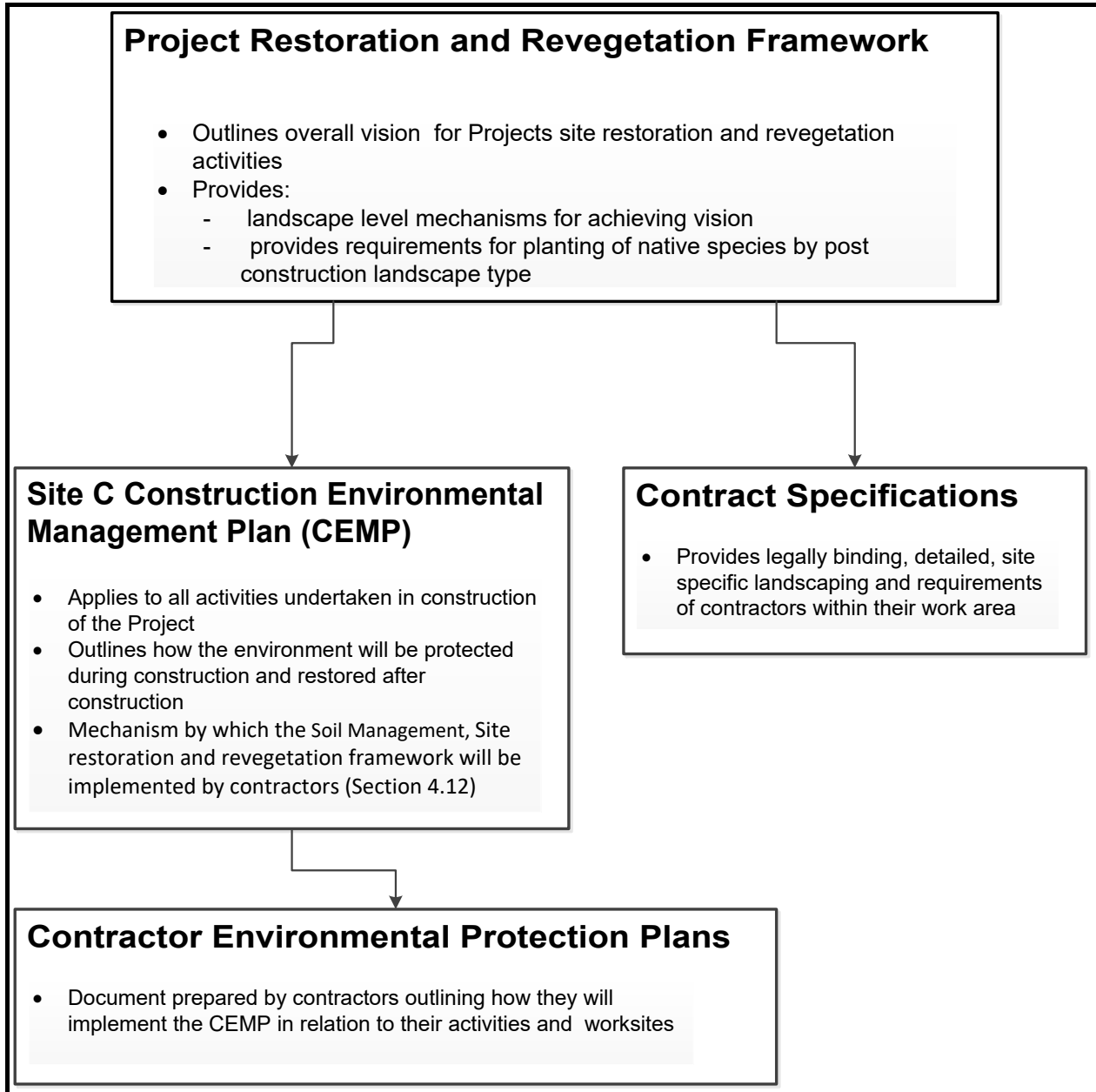

2.0 Objectives

The objectives of the site restoration and revegetation plan are to:

- Address the effects of dust and erosion on undisturbed ecosystems and their associated flora and fauna.
- Avoid mortality to plants and wildlife species due to the effects of dust and erosion.
- Address temporary loss of terrestrial ecosystems through restoration of ecosystems suitable for the post disturbance landscape.

3.0 Predicted effects on the biological values

The EIS (BC Hydro 2013) assessed the effects of the Project on wildlife and vegetation resources in terms of habitat losses during construction and operations. The EIS concluded that there would not be a significant adverse residual effect on ecosystems due to these losses.

Table 1 Reclamation and revegetation objective by Project area.

Project Component	Landscape categories within project component	Objective(s)	Mechanism	Approximate Area (ha)	Timing of revegetation
Dam Site	1. South aspect slopes 2. North aspect slopes 3. Riparian 4. Plateau	1. Control erosion and dust during construction/operations (See Section 3) 2. Establishment of self-sustaining native ecosystems in areas not needed during Project operations (See Section 4)	1. Seeding with erosion control grass seed mix 2. Implementation of Project's restoration and revegetation plan	42-erosion and dust control 41-riparian	1. Ongoing as required through construction 2. Areas to be re-vegetated within one year of completing construction activities in the area
Highway 29 Realignments	1. South aspect slopes 2. Plateau	Maintain safety and reliability standards along the highway	2012 Standard Specifications for Highway Construction Volume 2: Sections 751, 754 and 757	420	As per Specifications
Agricultural Lands	n/a	Return to pre-disturbance agricultural production or as directed by the landowner	Replacement of topsoil and re-establishing required vegetation	TBD	Areas to be re-vegetated within 1 year of completing of construction activities in the area
Transmission Line Right-of-way	Plateau	1. Re-establish native herb shrub vegetation 2. Control presence of trees that grow >5m to maintain electrical clearances and system safety and reliability	1. Natural re-vegetation 2. Vegetation maintenance	1010	Through natural re-growth of shrubs and herbs
85 th Avenue	Plateau	Re-vegetate to support future use as an industrial lands	1. Soil replacement 2. Landscaping 3. Planting of trees	100	Within 12 months of work finishing.
Area A	Creation of shallow water wetlands	Construct self-sustaining wetland habitats	1. Creation of topography and hydrology that mimics natural wetlands 2. Soil placement 3. Establishment of native wetland vegetation	171	Wetland construction will occur progressively across Area A after gravel extraction activities are completed

4.0 Soil Management

4.1 Broad mitigation objectives

The objectives of the soil management program are to:

- Have native soils available to use in site reclamation and revegetation activities.
- After disturbance manage soil so it can be used effectively in restoration works.
- Retain woody debris so that it can be used in restoration activities.

4.2 Strategies for achieving biological objectives

Soils stripped from construction areas and identified for retention will be handled in the following manner until they are needed for site reclamation and revegetation works:

- Identify and store appropriately soil, overburden material and coarse woody debris that could be used to create habitat features during site restoration.
- Upon completion of soil movement activities, restore site drainage patterns to natural flow conditions, where feasible.
- Design and construct stockpile slopes to reduce soil erosion.
- Restore soils within agricultural areas, including replacement of topsoil to maintain agricultural productivity in consultation with a Professional Agrologist.
- Minimize compaction of undisturbed soils to the extent feasible.

4.3 Tactics for achieving biological objectives

- Contract documents outline the areas where replacement of topsoil is required after construction is complete.
- Remaining salvaged soil will be used to assist in contouring the landscape in advance of revegetation works.

4.4 Implementation Schedule

Soil management activities occur throughout the construction phase. Soil management will be implemented beginning in 2015 and continue as required during Project construction.

4.5 Implementation Methods

Soil management will be implemented beginning in 2015 and continue as required during Project construction. Soil Management plans will be implemented by individual contractors in accordance with the Construction Environmental Management Plan as outlined in their Environmental Protection Plans within their work areas. Site specific requirements are outlined in contract documents, construction drawings, and in area specific reclamation and revegetation plans.

4.6 Monitoring

Contractor EPPs provide a monitoring plan that identifies monitoring intensity and parameters to be monitored, duration of monitoring and how results will be reported on and submitted to BC Hydro.

The BC Hydro Environmental Monitor and IEM will monitor areas in which soil, overburden and woody debris are stored as part of regular environmental site inspections.

4.7 Reporting and Publication

Reporting on soil management activities will occur as follows:

- Contractors report to BC Hydro either weekly or monthly in accordance with their EPP.
- The IEM submits weekly reports to EAO, FLNRO, CWR, CEAA, the Independent Engineer, and BC Hydro.
- BC Hydro submits monthly compliance reports to EAO, FLNRO, IEM, CEAA, and Aboriginal Groups.

5.0 Erosion and Dust Control

5.1 Broad mitigation objectives

The broad mitigation objectives are:

- To use vegetation to control erosion and dust within and adjacent to construction sites and facilities and in areas required during project operations.
- To establish a cover of native species robust enough to provide the ground cover and stability needed to control erosion and dust. The vegetation will be suitable for short term control during construction and long term control during operations.

5.2 Strategies for achieving biological objectives

The strategy to control erosion and dust generation will be to quickly establish a robust ground cover to protect exposed soil surfaces within construction areas from erosion and the associated dust production.

5.3 Tactics for achieving biological objectives

The following combination of weed free seed mixes will be applied on areas where erosion and dust control are needed. This combination aims to control erosion and dust in the short-term and establish a sustained native vegetation structure over the long-term. If a seed component is not available or a mix is proving to be unsuccessful, it may be substituted with an alternate mix, provided all non-native species are of an annual variety, the mix is endorsed by a QEP and it is accepted by BC Hydro:

Erosion and Sediment Control Seed mix

50% Fall rye
25% wheat
20% Annual Ryegrass
5% Hairy vetch

Native Seed Mix

47% Canada wild Rye
30% Slender wheatgrass
3% American vetch
10% Rough fescue
10% Rocky Mountain fescue

Both mixes will be applied simultaneously at a rate of 50-60 kg/ha. Fertilizer will only be applied if a qualified professional conducts a soil analysis to determine the nutrient composition of the soil and a fertilizer blend is developed based on that analysis.

In areas that require erosion and dust control mitigation, but that will be re-worked in less than 1-year (e.g., temporary soil stockpiles) or inundated, the Contractor may apply only the Erosion and Sediment Control seed mix.

A seed mix for use in the Highway 29 construction areas will be developed and approved by a QEP and accepted by BC Hydro. It will contain native seed and annual non-native seed species intended to facilitate quick revegetation for erosion and dust control, long term native ecosystem establishment and that is compatible with Ministry of Transportation and Infrastructure requirements.

5.4 Implementation Schedule

Within disturbed areas, seeds will be applied in the fall or early spring once erosion concerns have been addressed. Exact timing of revegetation will be determined by the contractor in accordance with their EPP.

5.5 Implementation Methods

The plan will be implemented by individual contractors in accordance with the Construction Environmental Management Plan as outlined in their Environmental Protection Plans within their work areas. Site specific requirements are outlined in contract documents, construction drawings, and in site specific reclamation and revegetation plans.

5.6 Monitoring

Monitoring will ensure that the strategies outlined in contractors EPP's are followed. Contractor EPPs provide a monitoring plan that identifies monitoring intensity and parameters to be monitored, duration of monitoring and how results will be reported on and submitted to BC Hydro.

The BC Hydro Environmental Monitor and the IEM will monitor seeded areas as part of their regular environmental site inspections.

5.7 Reporting and Publication

Reporting on erosion and dust control plantings to BC Hydro either weekly or monthly in accordance with their EPP.

- The IEM submits weekly reports to EAO, FLNRO, CWR, CEAA, the Independent Engineer, and BC Hydro.
- BC Hydro submits monthly compliance reports to EAO, FLNRO, IEM, CEAA, and Aboriginal Groups.

5.8 Data Management

Results of monitoring erosion and dust control plantings (e.g., survival, growth) will be submitted to BC Hydro and maintained in the Project database.

Seed purity certificates will be obtained for each batch of seed used.

5.9 Relevant Technical Expertise

The erosion and dust control seed prescription was developed by Pathfinder Endeavours. Reclamation and revegetation activities will be overseen by QEPs retained by contractors.

6.0 Site Reclamation and Revegetation

6.1 Broad mitigation objectives

To re-establish native vegetation communities on areas disturbed during Project construction that will not be needed during Project operations. The intended use of the areas after construction will determine how site reclamation and revegetation activities will be conducted and the type of vegetation re-established. Figure 2 provides an overview of the different areas and reclamation/revegetation objectives. Appendix A provides more detailed views of areas illustrated in Figure 2.

6.2 Biological objectives (for mitigation)

Highway 29

- Disturbed areas within the highway right-of-way will be reclaimed according to 2012 Standard Specifications for Highway Construction Volume 2: Sections 751, 754 and 757 to ensure safety and operational requirements are met.
- Disturbed areas adjacent to but outside the highway right-of-way that are being used for agricultural purposes will be restored as per the requirements of the landowner through replacement of topsoil, seeding and/or planting.

- Disturbed areas outside the highway right-of-way that are not being used for agricultural purposes will be revegetated with native species based on the landscape category of the disturbed area (see Section 4.3 below).

85th Avenue Industrial Lands:

- 85th Avenue Industrial Lands will be landscaped as per the specifications laid out in the Main Civil Works Contract which reflect the end use of this property as industrial lands.

Transmission Line Right-of-way:

- Allow re-growth of native herbs and shrubs within disturbed areas after clearing and construction activities are complete
- Maintain native herb and shrub vegetation within the right-of-way while at the same time restricting, through regular maintenance, occurrence of trees that grow >5m within the right-of-way to maintain electrical clearances for safety and system reliability

Figure 1. Locations of areas within which site restoration and re-vegetation will be conducted

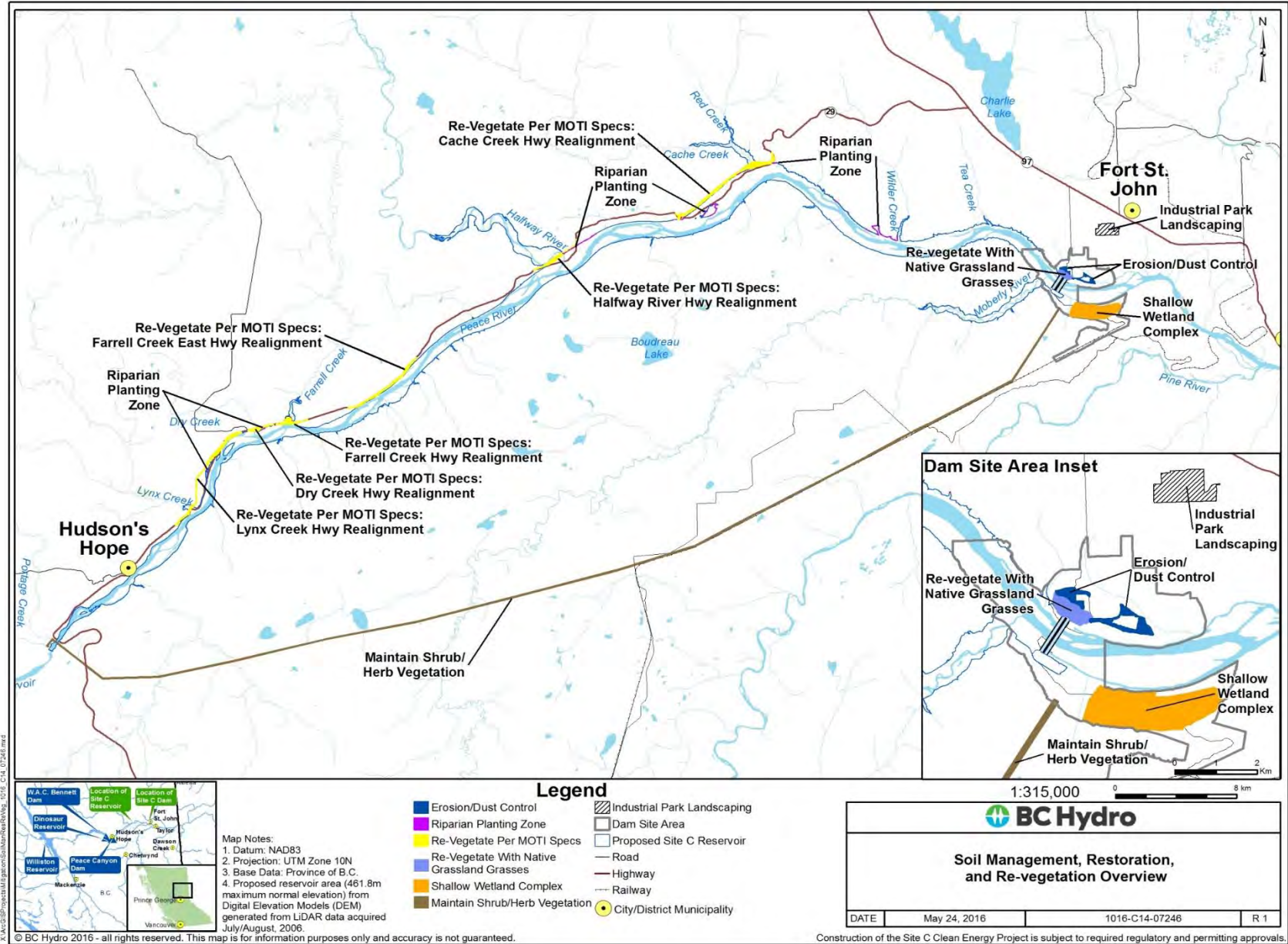

Area A at the dam site:

- Create self-sustaining wetland habitats within Area A.

Areas to be returned to natural ecosystems:

- Disturbed areas not needed for project operations and not within the Highway 29 and transmission line rights-of-way and not being used for agricultural purposes will be reclaimed and revegetated to re-establish self-sustaining ecosystems using ecological reclamation as described below.

6.3 Strategies for achieving biological objectives

Establishment of natural ecosystems

BC Hydro retained Dave Polster to develop a framework for establishing natural ecosystems. The following strategies will be used for achieving the objectives:

- The landscape within the Project footprint has been grouped into 4 categories to guide re-vegetation activities: south facing slopes (south aspect slopes with a grade >10%), north facing slopes (north aspect slopes with a grade >10%), riparian areas (transitional areas found within 15 m of the ordinary high water mark) and plateau areas areas with a grade <10% that are south aspect, north aspect or riparian).
- Re-establish the landform patterns associated with each landscape category prior to revegetation. This will be achieved through shaping of the area to match the surrounding topography, sculpting the surface to add micro topography, application of ecosystem elements (woody debris).
- Establishment of pioneering native vegetation suitable to the landscape category.

Since the original development of Appendix H, BC Hydro has learned more about the reclamation requirements of the site. Given these learnings, BC Hydro will conduct and monitor trials of modifications to the below prescriptions to determine the most appropriate reclamation strategy for the following four landscape categories and other sub-areas of the project as necessary. These trials will be overseen by a QEP between 2019 and 2021, with implementation of the selected strategies to occur thereafter.

6.4 Tactics for achieving biological objectives

South facing slopes

The objective of revegetation on south facing slopes is to re-establish native grassland ecosystems. This will be achieved by:

- Create naturally shaped landscapes that match the surrounding topography of the surrounding south aspect slopes.
- The surface will be scarified

- Woody debris will be scattered on the surface at densities of 25 m³/ha to 50 m³/ha as required.
- The area will be hydro seeded with a native grass seed mix composed of 50% Wild rye, 15% Slender wheatgrass, 5% Junegrass, 5% Spike trisetum, 5% Indian rice grass, 20% Rough fescue was applied at a rate of 54 kg/acre

Within the North Bank Stabilization area re-establishment to native grasslands will be conducted within the constraints of the engineered slope.

North facing slopes

The objective of revegetation on north facing slopes is to facilitate the establishment of mixedwood forests (deciduous and coniferous tree species). This will be achieved by:

- Creating naturally shaped landscapes that match the surrounding topography of the surrounding south aspect slopes.
- The surface will be scarified.
- Woody debris will be scattered on the surface at densities of 100 m³/ha.
- Planting with regionally appropriate trees and shrubs.

Riparian areas

The objective of revegetation in riparian areas is to facilitate the establishment of Balsam poplar ecosystems. This will be achieved by:

- Create naturally shaped landscapes that match the surrounding topography of the surrounding south aspect slopes.
- The surface will be scarified.
- Woody debris will be scattered on the surface at densities of 100 m³/ha.
- Planting with locally collected live stakes or rooted seedlings of 70% balsam poplar, 20% willow and 10% Red-osier dogwood.

Plateau areas

The objective of revegetation on plateau areas is to facilitate the establishment of mixedwood forests. This will be achieved by:

- Create naturally shaped landscapes that match the surrounding topography of the surrounding south aspect slopes.
- The surface will be scarified
- Woody debris will be scattered on the surface at densities of 100 m³/ha.
- Planting with regionally appropriate trees and shrubs

Reclamation areas will be monitored to confirm vegetation survival and growth. Maintenance requirements will be determined based on monitoring data.

Ongoing consultation with Indigenous Nations, including results of ground truthing will be used to

determine traditional use plants that can be seeded or planted within areas undergoing reclamation and revegetation.

6.5 Implementation Schedule

Disturbed areas no longer needed during construction or during operations will be progressively closed. These sites will be replanted within one year once erosion concerns have been addressed.

6.6 Experimental design/Adaptive Management framework

Plantings will be monitored to determine survival and growth. Additional species may be planted within sites to assist in community development. This will be determined on a site-by-site basis.

6.7 Baseline Data

When conducting revegetation activities the following baseline information will be used:

- Area A-the types and areas of wetlands that will be lost due to Project construction will be used to guide the creation of shallow wetlands within Area A.
- Habitats occurring on the landscape will be used to inform the types and compositions of ecosystems that will be restored on the landscape
- Species documented within habitats pre-disturbance will be used to determine species that will be used in revegetation activities.

6.8 Implementation Methods

The plan will be implemented by individual contractors in accordance with the Construction Environmental Management Plan as outlined in their Environmental Protection Plans within their work areas. Site specific requirements are outlined in contract documents, construction drawings, and in site specific reclamation and revegetation plans.

6.9 Monitoring

Monitoring will be conducted by BC Hydro to assess the effectiveness of reclamation and revegetation works. Monitoring plans will include inspection methods, effectiveness evaluations, measures for determining restoration success, short-term maintenance, monitoring timelines.

The requirements for monitoring work zones for noxious weeds and reporting on infestations is outlined in the Section 4.15 of the CEMP and in contractor Environmental Protection Plans. Treatment of any documented noxious weeds will be administered as per the BC Hydro Pest Management Plan.

6.10 Reporting and Publication

Reporting on site restoration and revegetation activities will occur as follows:

- Contractors report to BC Hydro either weekly or monthly in accordance with their EPP.
- The IEM submits weekly reports to EAO, FLNRO, CWR, CEAA, the Independent Engineer, and BC Hydro
- BC Hydro submits monthly compliance reports to EAO, FLNRO, IEM, CEAA, and Aboriginal Groups

6.11 Data Management

Results of revegetation monitoring (survival, growth) will be submitted to BC Hydro and maintained in the Project database.

Seed purity certificates will be obtained for each batch of seed used.

7.0 Relevant Technical Expertise

The reclamation and revegetation framework for the Project was originally developed by David Polster, R.P.Bio. Reclamation and revegetation activities will be overseen by QEPs retained by contractors and BC Hydro.

7.0 References

BC Hydro. 2013. Site C Clean Energy Project Environmental Impact Assessment. Volume 2, Section 14.

Ministry of Transportation and Infrastructure. 2012. Standard Specifications for Highway Construction. Volume 2

Appendix A. Detailed maps of restoration and revegetation areas

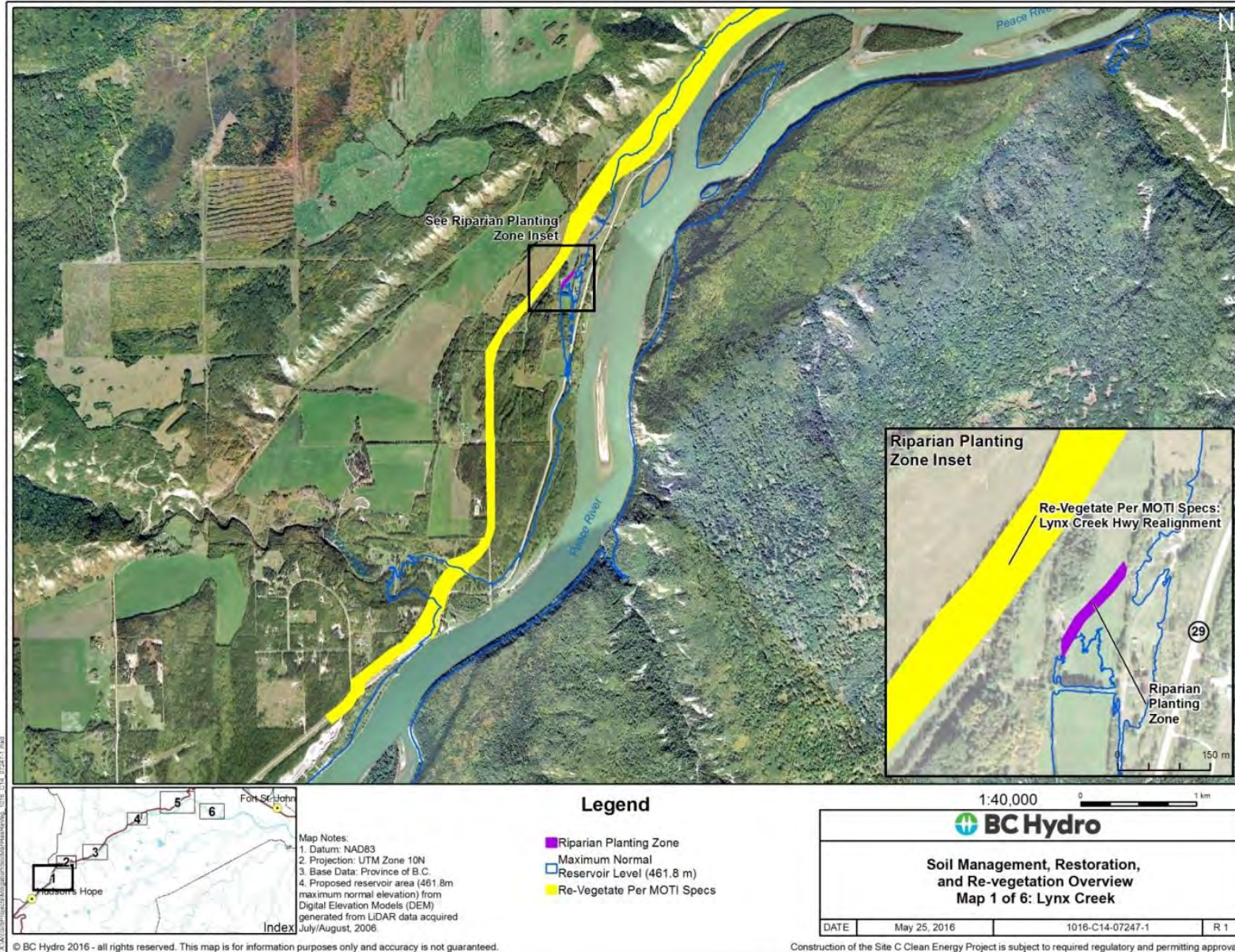

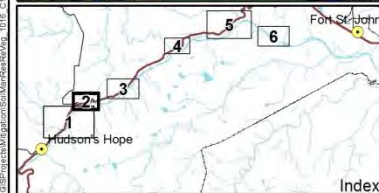
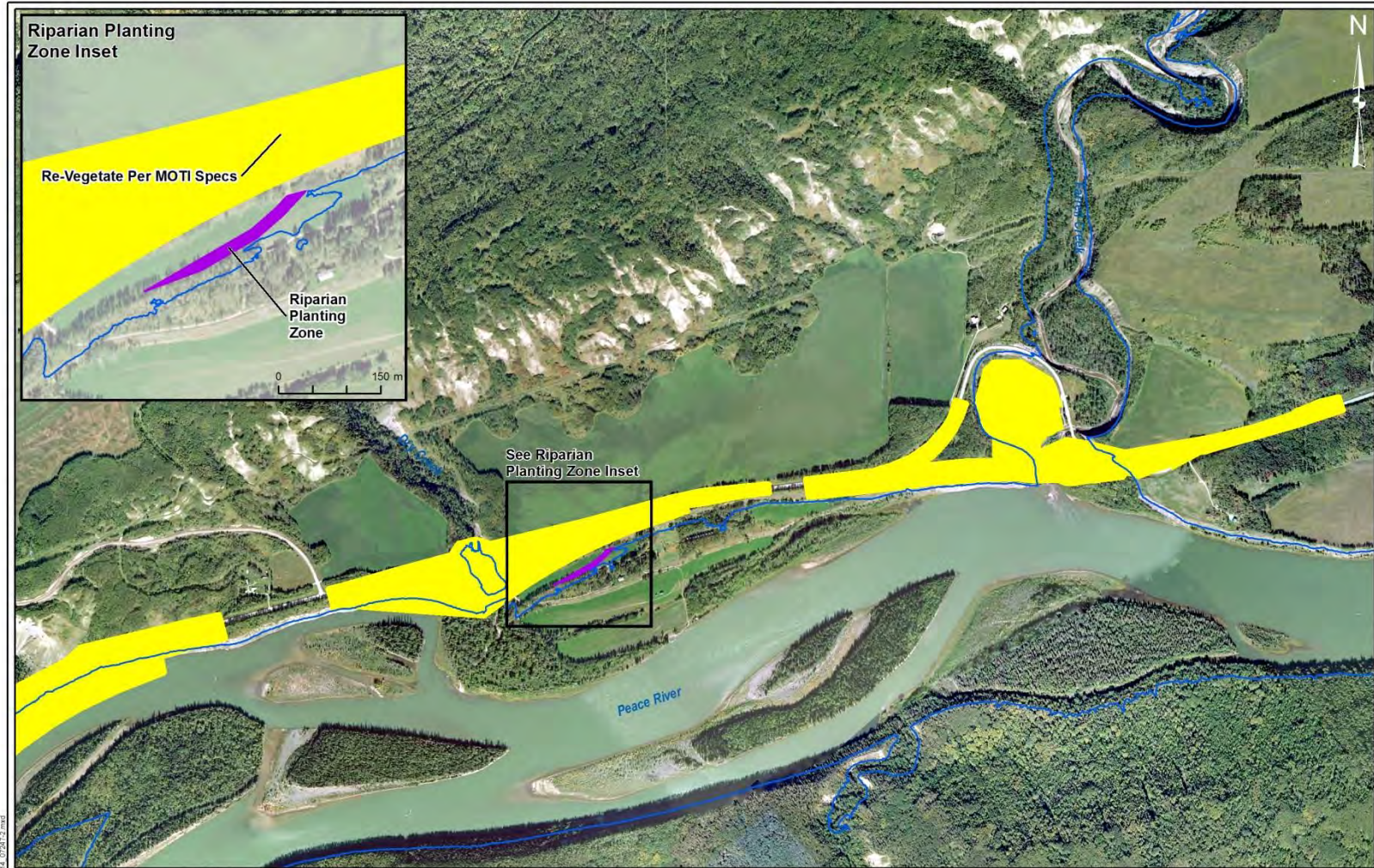

Map Notes:
 1. Datum: NAD83
 2. Projection: UTM Zone 10N
 3. Base Data: Province of B.C.
 4. Proposed reservoir area (461.8m maximum normal elevation) from Digital Elevation Models (DEM) generated from LIDAR data acquired July/August, 2006.

Legend

- Riparian Planting Zone
- Maximum Normal
- Reservoir Level (461.8 m)
- Re-Vegetate Per MOTI Specs (Right-of-Way/Corridors & Areas of Potential Disturbance)

1:20,000



**Soil Management, Restoration, and Re-vegetation Overview
Map 2 of 6: Farrell Creek**

DATE	May 25, 2016	1016-C14-07247-2	R 1
------	--------------	------------------	-----



Map Notes:
 1. Datum: NAD83
 2. Projection: UTM Zone 10N
 3. Base Data: Province of B.C.
 4. Proposed reservoir area (461.8m maximum normal elevation) from Digital Elevation Models (DEM) generated from LIDAR data acquired July/August, 2006.

Legend

- Riparian Planting Zone
- Maximum Normal Reservoir Level (461.8 m)
- Re-Vegetate Per MOTI Specs (Right-of-Way/Corridors & Areas of Potential Disturbance)

1:25,000

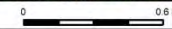

**Soil Management, Restoration,
and Re-vegetation Overview
Map 3 of 6: Farrell Creek East**

DATE	May 24, 2016	1016-C14-07247-3	R 1
------	--------------	------------------	-----

X:\A\GIS\Projects\MapServer\SiteC\MapServer\1016_C14_07247-3-1.mxd

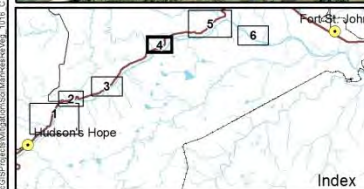
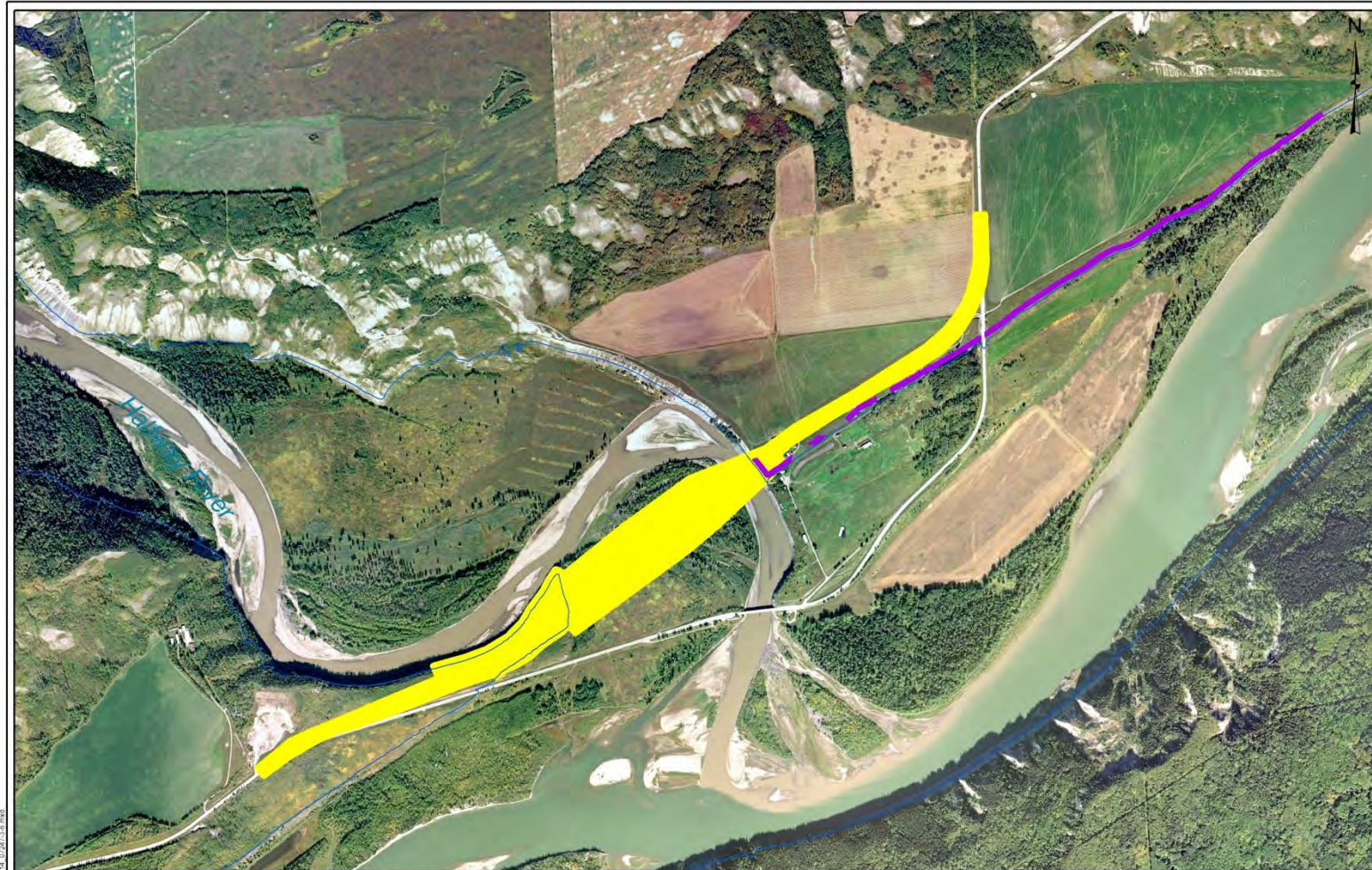

Map Notes:
1. Datum: NAD83
2. Projection: UTM Zone 10N
3. Base Data: Province of B.C.
4. Proposed reservoir area (461.8m maximum normal elevation) from Digital Elevation Models (DEM) generated from LIDAR data acquired July/August, 2006.

Legend

- Riparian Planting Zone
- Maximum Normal Reservoir Level (461.8 m)
- Re-Vegetate Per MOTI Specs (Right-of-Way/Corridors & Areas of Potential Disturbance)

1:20,000

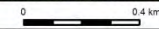

**Soil Management, Restoration,
and Re-vegetation Overview
Map 4 of 6: Halfway River**

DATE	May 24, 2016	1016-C14-07247-4	R 1
------	--------------	------------------	-----

X:\A\GIS\Projects\MapServer\MapServer\1016_C14_07247_4.rvt

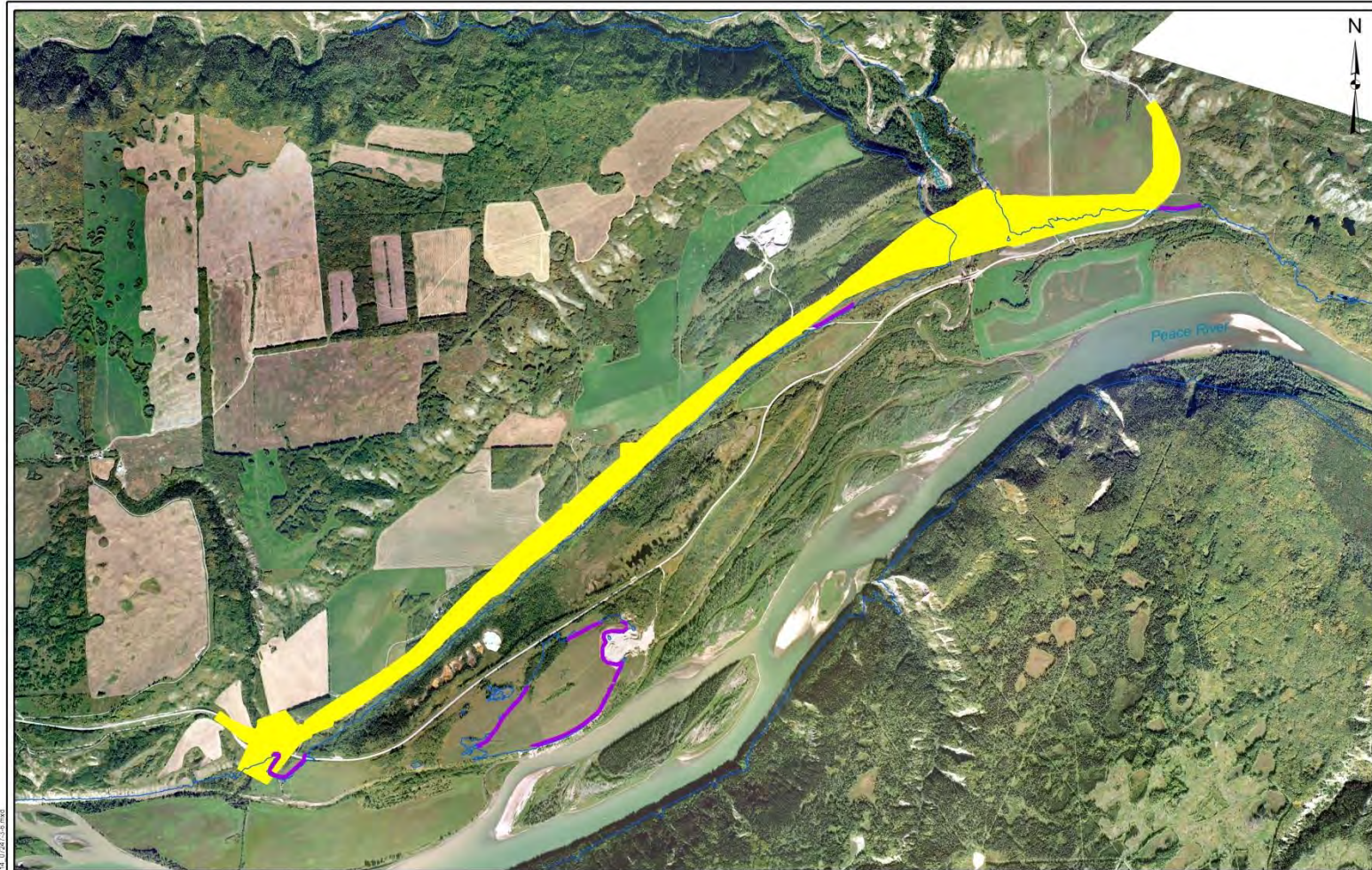

Map Notes:
1. Datum: NAD83
2. Projection: UTM Zone 10N
3. Base Data: Province of B.C.
4. Proposed reservoir area (461.8m maximum normal elevation) from Digital Elevation Models (DEM) generated from LIDAR data acquired July/August, 2006.

Legend

- Riparian Planting Zone
- Maximum Normal Reservoir Level (461.8 m)
- Re-Vegetate Per MOTI Specs (Right-of-Way/Corridors & Areas of Potential Disturbance)

1:35,000

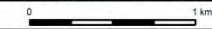

Soil Management, Restoration, and Re-vegetation Overview
Map 5 of 6: Cache Creek

DATE	May 24, 2016	1016-C14-07247-5	R 1
------	--------------	------------------	-----

X:\A\GIS\Projects\MapServer\MapServer\1016_C14_07247-5.rvt

© BC Hydro 2016 - all rights reserved. This map is for information purposes only and accuracy is not guaranteed.

Construction of the Site C Clean Energy Project is subject to required regulatory and permitting approvals.

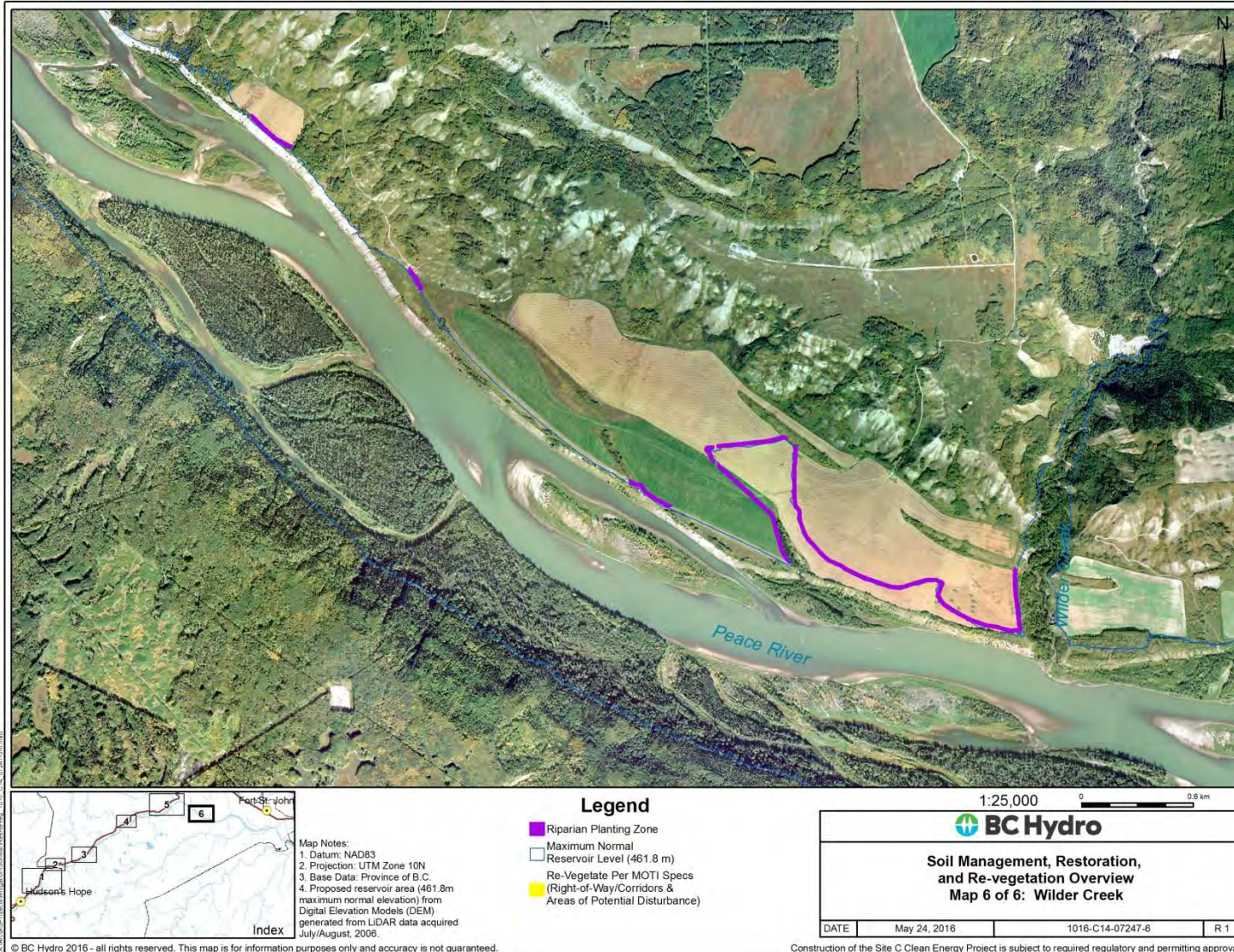

Appendix I Erosion and Sediment Control Plan

Appendix I

Erosion and Sediment Control Plan

Site C Clean Energy Project

Revision 1: July 8, 2016

Revision History

Version	Date	Comments
Rev 1	07-08-2016	Final Plan

SITE C CLEAN ENERGY PROJECT

WATER MANAGEMENT, EROSION AND SEDIMENT CONTROL PLAN

Revision 1

Prepared by

Klohn Crippen Berger Ltd. and SNC-Lavalin Inc.

For

BC Hydro

SITE C CLEAN ENERGY PROJECT

**WATER MANAGEMENT, EROSION
AND SEDIMENT CONTROL PLAN**
Revision 1

Prepared by

Klohn Crippen Berger Ltd. and SNC-Lavalin Inc.

For

BC Hydro

SITE C CLEAN ENERGY PROJECT

WATER MANAGEMENT, EROSION AND SEDIMENT CONTROL PLAN Revision 1

Prepared by:



Winston Wade, MEM, P.Eng.
SNC-Lavalin Inc.



Cory Turkington, CPESC
SNC-Lavalin Inc.

Checked by:



Nicole Anderson, CPEng.
Klohn Crippen Berger Ltd.

Reviewed by:

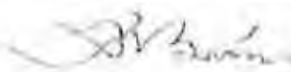

Ali Biner, P.Eng.
SNC-Lavalin Inc.



Brian McGhee, P.Eng. CEng. MICE
Klohn Crippen Berger Ltd.

Accepted by:

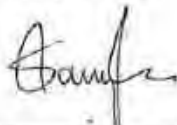

Simon Douglas, P.Eng.
Klohn Crippen Berger Ltd.



Bernard Gagné, P.Eng.
SNC-Lavalin Inc.



Andrew Watson, P.Eng.
BC Hydro

DISCLAIMER

This plan was prepared by Klohn Crippen Berger Ltd. and SNC-Lavalin Inc. solely for BC Hydro internal purposes. All other parties are third parties.

Neither BC Hydro nor Klohn Crippen Berger Ltd. nor SNC-Lavalin Inc. represents, guarantees or warrants to any third party, either expressly or by implication:

- (a) the accuracy, completeness or usefulness of;
- (b) the intellectual or other property rights of any person or party in, or
- (c) the merchantability, safety or fitness of purpose of,

any information, product or process disclosed, described or recommended in this plan.

Neither BC Hydro nor Klohn Crippen Berger Ltd. nor SNC-Lavalin Inc. accept any liability of any kind arising in any way out of the use by a third party of any information, product or process disclosed, described or recommended in this plan, nor do BC Hydro, Klohn Crippen Berger Ltd. nor SNC-Lavalin Inc. accept any liability arising by way of reliance by a third party upon any information, statement or recommendation contained in this plan.

Should third parties use or rely on any information, product or process disclosed, described or recommended in this plan, they do so entirely at their own risk.

COPYRIGHT NOTICE

© 2016 BC Hydro. This plan may not be reproduced in whole or in part without the prior written consent of BC Hydro.

LIST OF ACRONYMS

ARD/ML	Acid Rock Drainage/Metal Leaching
BCEAO	BC Environmental Assessment Office
BCWGs	British Columbia Water Quality Guidelines
BC	British Columbia
BMP	Best Management Practice
CDA	Canadian Dam Association
CCME	Canadian Council of Ministers of the Environment – Water Quality Guidelines
CEMP	Construction Environmental Management Plan
DBM	Design Basis Memorandum
DFO	Department of Fisheries and Oceans
EI.	Elevation
EM	Environmental Manager/Monitor
EPP	Environmental Protection Plan
ESC	Erosion and Sediment Control
IET	Integrated Engineering Team
KCB	Klohn Crippen Berger Ltd.
LBE	Left Bank Excavation
m	metre
m/s	metres per second
m ³ /s	cubic metres per second
MCW	Main Civil Works
MELP	Ministry of Environment, Lands and of Parks
MEM	Ministry of Energy and Mines
MOE	Ministry of Environment
NBCC	National Building Code of Canada
PCN	Peace Canyon Dam
P Eng	Professional Engineer
QP	Qualified Professional
RCC	Roller Compacted Concrete
RSEM	Relocated Surplus Excavated Material
RUSLE	Revised Universal Soil Loss Equation
SEV	Severity of Ill Effects
SCS	Soil Conservation Service
SLI	SNC-Lavalin Inc.
WM	Water Management
WQ	Water Quality
WSC	Water Survey of Canada

SITE C CLEAN ENERGY PROJECT

WATER MANAGEMENT, EROSION AND SEDIMENT CONTROL PLAN REVISION 1

CONTENTS

<u>Section</u>	<u>Subject</u>	<u>Page</u>
	EXECUTIVE SUMMARY	IX
1.	INTRODUCTION	1
1.1	General	1
2.	ROLES AND RESPONSIBILITIES	3
2.1	BC Hydro	3
2.2	Contractors	3
3.	DESIGN BASIS FOR EROSION AND SEDIMENT CONTROLS	6
3.1	Water Quality Criteria.....	6
3.2	Climate.....	6
3.3	Design Rainfall.....	8
3.4	Runoff Coefficients	8
3.5	Temporary Structures	8
3.6	Sedimentation Pond Design	9
3.7	Reference Documents	10
4.	EROSION AND SEDIMENTATION CONTROLS	11
4.1	ESC Approach Preferences	11
4.2	Erosion Potential.....	12
4.3	Erosion and Sedimentation Control Measures.....	12
4.4	ESC Measures.....	28
5.	ESC CONTROLS FOR PROJECT AREAS.....	41
5.1	General	41
5.2	Left Bank Excavation	43

SITE C CLEAN ENERGY PROJECT

WATER MANAGEMENT, EROSION AND SEDIMENT CONTROL PLAN REVISION 1

CONTENTS

<u>Section</u>	<u>Subject</u>	<u>Page</u>
5.3	RSEM Area L3.....	44
5.4	RSEM Area L5.....	46
5.5	RSEM Area L6.....	48
5.6	RSEM Area R5a and R5b.....	49
5.7	RSEM Area R6.....	51
5.8	Road Construction.....	52
5.9	Rail Siding.....	54
6.	REFERENCES.....	56

APPENDICES

Appendix A	ESC Best Management Practices
Appendix B	Referenced Drawings

TABLES

Table 3-1	Rainfall Intensity Duration Frequency at Fort St. John Airport Climate Station (1973 - 2002).....	8
Table 3-2	Sedimentation Pond Performance Criterion Guidelines.....	9
Table 4-1	Suitability of ESC Practices for Various Construction Activities.....	12
Table 4-2	Application of Best Management Practices.....	14
Table 4-3	Suggested armouring of Drainage Channels.....	32
Table 4-4	ESC Considerations on Temporary Soil Slopes.....	33
Table 4-5	Suggested Minimum Slope Drain Diameter Based on Contributing Area	34
Table 4-6	Suggested Spacing for Check Dams.....	35
Table 5-1	Suggested ESC Measures by Area.....	42

SITE C CLEAN ENERGY PROJECT

WATER MANAGEMENT, EROSION AND SEDIMENT CONTROL PLAN REVISION 1

CONTENTS

<u>Section</u>	<u>Subject</u>	<u>Page</u>
Table 5-2	LBE ESC Measures.....	43
Table 5-3	RSEM AREA L3 ESC Measures.....	45
Table 5-4	RSEM AREA L5 ESC Measures.....	46
Table 5-5	RSEM AREA L6 ESC Measures.....	48
Table 5-6	RSEM AREA R5a R5b ESC Measures.....	49
Table 5-7	RSEM Area R6 ESC Measures	51
Table 5-8	Rail Siding ESC Measures.....	54

FIGURES

Figure 3-1	Mean Daily Temperature for Fort St. John.....	7
Figure 3-2	Mean Monthly Precipitation for Fort St. John	7
Figure 1:	Site Disturbance Overview and Catchment Maps	
Figure 2:	Schematic of LBE Hydraulic Flow Pathways and ESCs by Construction Phase	
Figure 3:	Schematic of RSEM Area L3 Hydraulic Flow Pathways and ESCs by Construction Phase	
Figure 4:	Schematic of RSEM Area L5 Hydraulic Flow Pathways and ESCs by Construction Phase	
Figure 5:	Schematic of RSEM Area L6 Hydraulic Flow Pathways and ESCs by Construction Phase	
Figure 6:	Schematic of Area R5a and R5b Hydraulic Flow Pathways and ESCs by Construction Phase	
Figure 7:	Schematic of Area R6 Hydraulic Flow Pathways and ESCs by Construction Phase	
Figure 8:	Schematic of Septimus Siding Hydraulic Flow Pathways and ESCs by Construction Phase	

EXECUTIVE SUMMARY

The following document presents BC Hydro's plan for Erosion and Sediment Control (ESC) at the Site C Clean Energy Project. The plan includes the following:

- Defines the roles and responsibilities of BC Hydro and the Contractors regarding Erosion and Sediment Control;
- Provides specific actions to be taken to prevent the erosion of soils and transportation of sediment, for the physical components of the Project and until such time as all construction-related disturbances are fully reclaimed and not at risk of erosion;
- Identifies specific water management, erosion control and sediment control mitigation measures, and under what conditions these mitigation measures may be employed. This guide provides a range of suitable BMPs that work in various situations and the Contractors may adopt in their Environmental Protection Plans (EPPs); and
- Identifies appropriate water management, erosion control and sediment control mitigation measures that are to be implemented prior to starting work, and during the conduct of the work. Measures to be undertaken are described in the Water Management Plan for the RSEM areas (KCB-SLI, 2014), and the construction drawings and specifications for the project, for areas such as the Left Bank Excavation, the 85th Avenue till source, and various other disturbed areas.

BC Hydro will audit Contractor compliance with the EPP and applicable construction and engineering plans for the Project. BC Hydro will also review and approve revisions to these Contractor prepared plans.

As the Contractors must prepare the EPP and applicable construction and engineering plans subject to project requirements and permit requirements, this document presents a guidance framework that the Contractors must follow when developing their EPPs. The Contractors' EPPs must be site and schedule specific, and be adapted, updated, and approved as required to respond to the changing site conditions.

1. Introduction

1.1 General

The Site C Clean Energy Project (herein referred to as the ‘Project’) will be located 83 km downstream of Peace Canyon Dam (PCN), 7 km southwest of Fort St. John, downstream of the confluence of the Moberly River and Peace River. Construction of the Project and associated facilities will be carried out over approximately 8 years. The work will include the excavation of overburden and shale bedrock, which will be placed in six Relocated Surplus of Excavated Material (RSEM) areas, and other construction activities with the potential to impact the environment.

This Water Management, Erosion and Sediment Control Plan (herein referred to as the ‘Plan’) has been prepared to provide guidance in maintaining compliance with Project requirements related to drainage management and erosion and sediment control (ESC) during construction of the Project. The authors have assessed the erosion and sediment concerns, identified potential effects, and recommended mitigation strategies.

The objectives of the strategies identified in this plan are to:

- Minimize the disturbance of existing vegetation and soil on the construction site;
- Prevent erosion (incl. wind erosion), during construction activities; and
- Prevent sediment-laden water and/ or sediment from the work area entering the Peace River or other watercourse.

This plan has been prepared with consideration of the requirements outlined in Section 4.4 – ‘*Erosion Prevention and Sediment Control Management*’ – of the Project’s Construction Environmental Management Plan (CEMP) (Revision 2) dated February 4, 2016. A third revision to the CEMP is currently being completed in response to received regulator comments. This plan will be updated as required in consideration of the requirements of Revision 3 of the CEMP.

This document has been developed based on best practice, with the goal of managing site drainage, controlling potential erosion and preventing the offsite migration of sediment (incl. sediment-laden water). Contractors shall follow the guidance in this document in the selection, installation and maintenance of appropriate water management and ESC measures throughout the project area.

This Plan is an overarching erosion and sediment control plan that cannot systematically provide all project-wide or activity specific detail as, given the temporal scale (approx. 8 years) and size of the Project where activity will increase towards a peak period and where change is often the only constant, the plan would

become unmanageably large and would also need to be amended continuously to reflect new information. Therefore, a hierarchy of environmental plans will be developed as part of implementing an erosion and sediment control for the Project.

At the top of the hierarchy is this document, which will function as an overarching plan that can be generalized to the Project as a whole. Under the Plan, more detailed plans called Environmental Protection Plans (EPPs) will be developed for site specific areas and in some cases specific construction activities. Section 2.4 of the CEMP describes the minimum requirements to be included in an EPP. The EPPs will convert this Plan's ESC guidance and requirements into a form that better fits how construction is organized and managed, which is typically by area and activity. In that way, the EPPs will serve as an instrument to efficiently pass relevant ESC information to construction personnel engaged in specific activities. At the base of the hierarchy of plans are highly specific ESC Work Plans that will be prepared, and their installation overseen, by a qualified Professional and/or the Engineer whose qualifications are defined by the plan (see Section 2.2.1). Relevant environmental information will be extracted from EPPs and inserted into ESC Work Plans, to be integrated with other information relevant to specific construction activities, such as hazard assessment/analysis, safety requirements, activity sequence, etc.

Further, during construction, at least once every 12 months, and more often as may be required, BC Hydro will review the CEMP (see Section 2.6 of the CEMP). This commitment to review of the CEMP will extend to this Plan. At a minimum, BC Hydro will review and revise this Plan on annual basis. Examples of information to be reviewed include; construction schedule, agency requirements, lessons learned, mitigation measures, forecasted weather conditions, etc. The review of the Plan will involve BC Hydro, IEM and Contractor(s).

2. ROLES AND RESPONSIBILITIES

2.1 BC Hydro

BC Hydro is responsible for:

- Ensuring all Contractors on the Site C Project adhere to the guidelines identified in this Plan;
- Reviewing and approving EPPs and applicable construction and engineering plans, including ESC plans, prepared by its Contractors.
- Reviewing and approving revisions to EPPs and applicable construction and engineering plans to respond to changes in site conditions.
- Auditing Contractor compliance with EPPs and applicable construction and engineering plans.

2.2 Contractors

2.2.1 Contractors' Responsibilities

The Contractors' environmental obligations and responsibilities are outlined in Section 2.3 of the CEMP. In addition to Contractors' are responsible for:

- Developing and implementing erosion and sediment control prescriptions under the direction of a Qualified Professional (QP) and / or Professional Engineer.
- Using guidance provided in this Plan, the CEMP and Environmental Requirements to develop water management, erosion and sediment control mitigation measures that are site specific and implemented prior to starting works, during the conduct of work, and after works are completed and that all the works installed pursuant to the plan are monitored and maintained to ensure effectiveness.

For the purpose of this plan a QP and Professional Engineer are defined as follows:

- "Qualified Professional" means an applied scientist or technologist specializing in an applied science or technology applicable to erosion and sediment control planning, design and implementation; and who is registered with the appropriate professional organization in the Province of British Columbia (BC); is acting under the organization's code of ethics and is subject to disciplinary action by that organization; and who is an Accredited Professional with the Erosion and Sediment Control Association of Canada.
- "Professional Engineer" means an engineer who is licensed to practice engineering in the Province of BC and is in good standing with

Association of Professional Engineers and Geoscientists of British Columbia; and who has demonstrated experience in assessing, planning, and implementing water management, erosion control, and sediment control measures for major construction projects.

2.2.2 Documentation

The Contractors are responsible for preparing and implementing Environmental Protection Plans (EPPs) and/ or Erosion and Sediment Control (ESC) Plans that demonstrate how the Contractors will install, inspection and maintain ESC measures described in this Plan. As required, the EPPs or ESC Plans will be updated to account for changing site conditions. In the event that the Contractors proposed work method deviates from an EPP or ESC Plan, the Contractors' QP and / or Professional engineer must document, approve, and oversee installation and maintenance on the revised plan.

2.2.3 Inspection

Contractors are responsible for inspecting all ESC measures installed during the course of the project. Regular inspections are required at a frequency commensurate with the risk, nature, location and seasonality of the work. Inspections must be completed and documented during, or within 24 hours of, heavy snowmelt and heavy and/or prolonged rainfall (defined as >12 mm precipitation within any 24 hour period, or precipitation or snowmelt on wet or thawing soils).

Following an extreme weather event (defined as >25mm precipitation within any 24 hour period), Contractors will be responsible for inspecting ESC measures and overseeing site cleanup and re-establishment of the ESC controls.

The environmental inspection program is intended to be a mechanism to implement ESC adaptive management at the site level. The program provides a system for identifying construction related environmental issues or deficiencies and quickly implementing preventive or corrective actions to resolve those issues and deficiencies before they can escalate to severe non-conformities. The Contractor appointed Environmental Monitor will work with their Contractor to identify measures that the Contractor will implement to prevent or correct ESC issues or deficiencies identified by the Independent Environmental Monitor (IEM). The IEM will be responsible for conducting site visits to determine if the Contractor(s) meets ESC performance requirements and to confirm that required or appropriate ESC measures are being effectively implemented on site (i.e., as described in the EPP).

2.2.4 Maintenance

As part of the inspection process, ESC issues will be identified and documented, as specified in the EPP. It will be responsibility of the Contractors to address the

issues identified in the inspection program. For example, all sediment control measures that have accumulated sediment in or immediately around them will be cleaned once sediment build-up is one-third to one-half of the device's retention capacity.

Maintenance will also occur immediately after problems are identified and will be done in a manner that will prevent further sediment migration. The Contractors are responsible for documenting and reporting on maintenance activities.

2.2.3 Contingency

The Contractors are responsible for storing and maintaining ESC contingency supplies onsite. The contingency supplies must be readily accessible, clearly identifiable, and of sufficient quantity to respond to an event. EPPs must indicate and describe the minimum supply of contingency supplies to be kept onsite, relevant to the work.

3. DESIGN BASIS FOR EROSION AND SEDIMENT CONTROLS

The design basis for water management structures was presented in the Water Management Plan for the RSEM areas (KCB-SLI, 2014). Relevant design data is summarized in this Section for reference.

Sediment control systems including ditches, retention ponds and settling ponds shall be designed by a Qualified Environmental Professional. Design details including calculations shall be submitted to BC Hydro.

3.1 Water Quality Criteria

During construction, runoff from disturbed areas will be collected and directed towards sedimentation ponds. Water quality criteria upland of the Peace River is defined Section 4.14 – Surface Water Quality Management – of the CEMP. The water quality from surface flow discharging to upland drainages must meet BC Water Quality Guidelines (BCWQG) (Caux et al., 1997).

The water quality criteria for in river works associated with the Peace River is based on a severity-of-ill-effects (SEV) criteria as outlined in the CEMP and applicable Fisheries Act Authorization. Water quality discharging to the Peace River must stay within the assimilative capacity of the Peace River.

3.2 Climate

Data from the Fort St. John Airport Climate Station is summarized below. Mean daily temperatures are provided in Figure 3-1 and mean monthly precipitation is provided in Figure 3-2.

- Annual average daily temperature is 4.1°C:
 - Highest temperatures occur in Summer (June to August); and
 - Temperatures are below 0°C November to March with the lowest temperatures occurring in January.
- Average annual precipitation is 466 mm (approximately 313 mm as rain and 153 mm as snow water equivalent):
 - Highest precipitation (rainfall) occurs in June/July; and
 - Lowest precipitation (rainfall) occurs in April.
- Peak annual runoff occurs in:
 - Freshet - April (21%); and
 - Summer - July (17%).
- Average annual lake evaporation (631 mm/year):
 - Spring/summer - 93%; and Fall/winter - 7%.

Figure 3-1 Mean Daily Temperature for Fort St. John

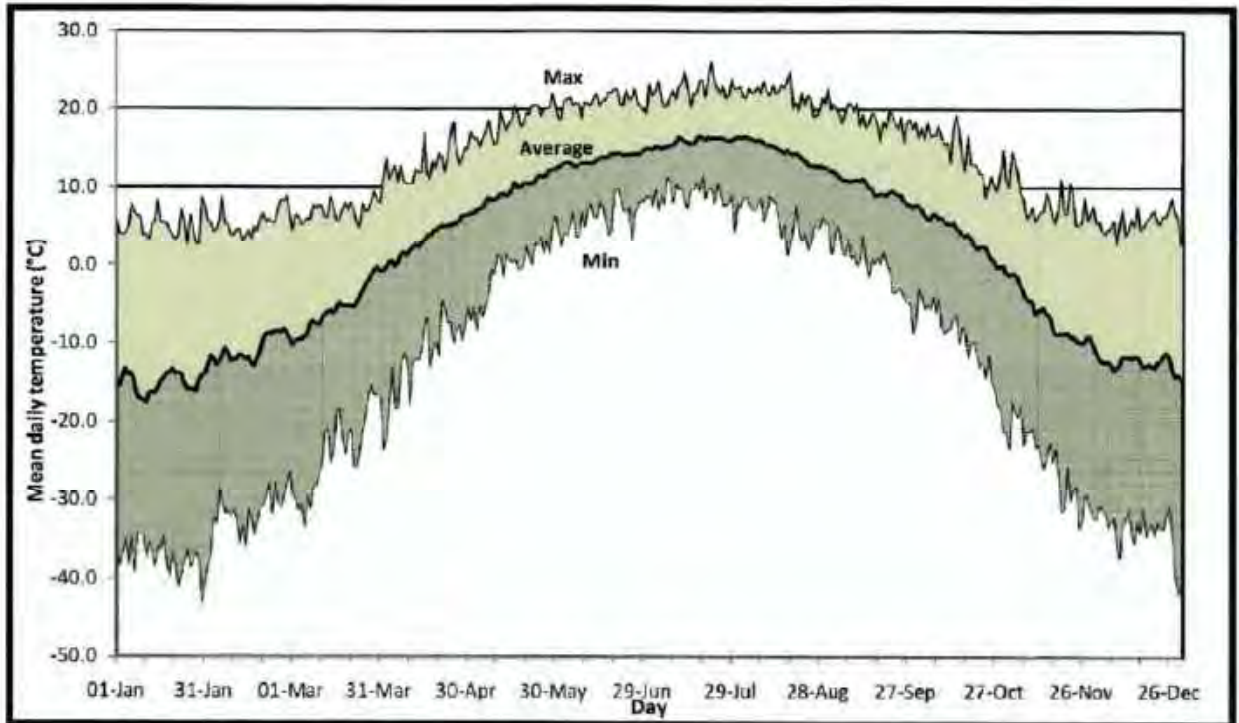
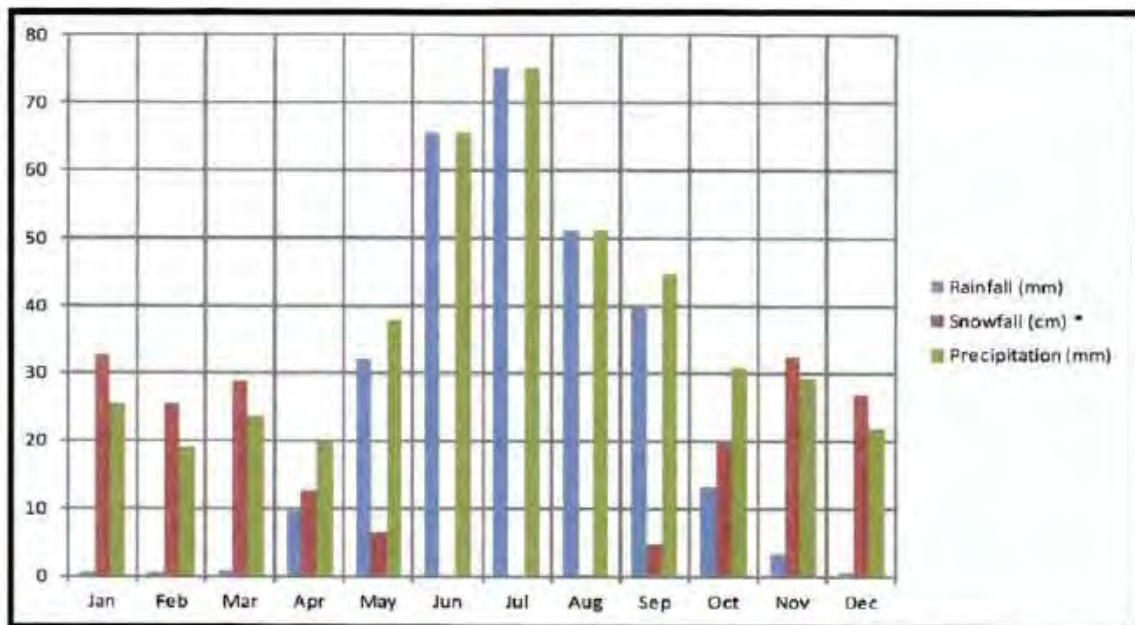

Figure 3-2 Mean Monthly Precipitation for Fort St. John



* DENSITY OF SNOW VARIES WITH TEMPERATURE AND IS ON AVERAGE 0.8mm OF WATER FOR 1cm OF SNOW

3.3 Design Rainfall

The Environment Canada rainfall Intensity Duration Frequency data at the Fort St. John Airport Climate Station was used as the design rainfall for the Project (refer to Table 3-1 **Error! Reference source not found.**).

Table 3-1 Rainfall Intensity Duration Frequency at Fort St. John Airport Climate Station (1973 - 2002)

Duration	Precipitation (mm) for Return Periods (years)						
	2	5	10	25	50	100	200 ⁽¹⁾
5 Min	4.4	6.4	7.8	9.5	10.7	12.0	14.6
10 Min	6.3	8.8	10.5	12.7	14.3	15.9	19.1
15 Min	7.6	10.7	12.8	15.4	17.3	19.3	23.3
30 Min	10.1	14.5	17.4	21.1	23.8	26.5	31.9
1 Hour	11.9	16.9	20.2	24.5	27.6	30.7	36.9
2 Hour	13.9	19.5	23.2	27.9	31.3	34.8	41.8
6 Hour	20.4	26.8	31.1	36.5	40.5	44.5	52.5
12 Hour	27.9	35.6	40.7	47.2	52.0	56.7	66.1
24 Hour	35.6	44.6	50.5	58.0	63.6	69.1	80.1

Notes:

- (1) The 200 year values were extrapolated from the other return periods.
- (2) Data reproduced from Environment Canada
 (http://climate.weather.gc.ca/prods_servs/engineering_e.html).

3.4 Runoff Coefficients

Runoff coefficients were based on the Manual of Operational Hydrology in British Columbia. Typical runoff coefficients used for the 10-year 24-hour storm event include:

- RSEM areas: 0.8;
- Excavated areas: 0.9; and
- Core trench: 1.0.

The values adopted for other areas of the site by the Contractors' Qualified Professional should be stated in the EPP for approval by BC Hydro.

3.5 Temporary Structures

- Design flow event – 10-year return period 24-hour duration (10-year 24-hr) or 50.5 mm (Table 3-1). Storm event flows must be routed through structures that are suitably armoured to prevent erosion.

- Design settling event - 10-year return period 24-hour duration (10 year 24-hr). Particles with diameter greater than 10 µm are settled within the structure and not discharged to the environment.

3.6 Sedimentation Pond Design

The design criteria adopted for the design of sedimentation ponds are based on the MELP Guidelines (MELP, 2001), which are summarized below and in Table 3-2:

- Design flow for removal of suspended solids: 10-year 24-hour event;
- Minimum permanent water depth: 0.5 m (over sediment storage);
- Pond depth above permanent water depth: to manage 10-year 24-hour runoff volume;
- Design flow for emergency spillway: 200-year 24-hour event;
- Length to width ratio: 5 to 1 (minimum);
- Retention time: calculated using Stokes Law for a 10 µm particle (with a kinematic viscosity of water temperature of 10°C);
- Sediment storage depth: based on annual sediment volume, accumulating in sediment pond area only; and
- Regular inspections and clean outs are required as part of on-going maintenance for each sedimentation pond to maintain a minimum sediment depth of 0.5 m below outlet invert.

Table 3-2 Sedimentation Pond Performance Criterion Guidelines

Guideline	Criteria
Ministry Environment, Lands and of Parks Guidelines (MELP, 2001), Guidance for Assessing the Design, Size and Operation of Sedimentation Ponds	<ul style="list-style-type: none"> • Provides guidelines for the sizing of sediment ponds for mine sites. Three methods are presented for estimating the design settling velocity for sizing the sediment pond. Method 1 is based on estimating settling velocity from physical testing. Method 2 (known TSS particle distribution) and 3 (unknown TSS particle distribution) are based on estimating the settling velocity of a particle of “x” mm size using Stoke’s Law and removing the particle by a sediment pond area of A m². • In the absence of settling tests, Method 3 assumes that particles greater than 10 µm are to be settled within the sediment pond (without consideration of agglomeration).

3.7 Reference Documents

The following section outlines the relevant reference documents that were taken into consideration while preparing this Plan and may be further relied on by the Contractors.

- Environmental Assessment Certificate #14-02, issued October 14, 2014
- Construction Environmental Management Plan Rev 2, dated February 4, 2016
- BC Hydro Technical Specifications:
 - 31 11 00 – Clearing, Grubbing and Stripping
 - 31 23 00 – Surface Excavation
 - 31 40 00 – Relocated Surplus Excavation Materials
 - 31 80 00 – Care of Water
- DFO *Land Development Guidelines for the Protection of Aquatic Habitat*, dated 1993
- FLNRO *Standards and Best Practices for Instream Works*, dated March 2004

In addition, BC Hydro has produced a water management plan that forms the design basis for the water management structures and water handling for the main civil works component of the Project. The water management plan is presented in the following document:

- Site C Clean Energy Project, Implementation Design, Reference Concept Report - RSEM and Excavation Area Water Management dated November 2014, prepared by the IET.

4. Erosion and Sedimentation Controls

4.1 ESC Approach Preferences

The Project will follow an ESC approach that reduces sediment-laden water by selecting mitigation measures that emphasize erosion control. Across the Site C Clean Energy Project, there are expansive engineered design structures and work areas that are constantly under construction within which there is an opportunity to isolate contact water from local water courses (see Section 7). Within these areas the ESC conceptual approach is to:

1. Minimise contact water by minimising disturbed areas, and diverting non contact water away from construction areas (such as interception ditches above construction areas);
2. Within the construction areas, direct contact water to designated centralised water treatment areas minimising sediment transport through small sediment interception BMPs (such as check dams);
3. Collect and treat contact water in centralised BMP locations with sufficient capacity to manage the design storm (primarily temporary sediment ponds); and
4. Treat and discharge high quality water to a designated water course, infiltration areas or other area with a direct connection to a natural water course.

For these isolated construction areas with sufficient capacity to capture and manage design storms, there is not an expectation to provide erosion control measures on the surfaces themselves other than at the contractors own discretion to minimise maintenance and operation of his primary ESC measures (e.g., ponds, channels, etc.)

There are two exceptions to this approach which are: smaller areas that cannot be isolated up to the design storm from water courses; and, areas achieving final design grade. Within these areas, surface erosion BMP's should be implemented to control surface erosion in combination with appropriate engineered structures (e.g., ponds, channels, etc.) to manage up to and including the design storm. The goal of these areas is to manage sediment and erosion until permanent vegetation requirements/measures have been established at which point they would be decommissioned.

Section 5 below provides conceptual details of this approach for the major construction areas for the Project.

4.2 Erosion Potential

The erosion potential at the Site C Project is considered to vary from-low to high depending on the specific location. Soil in the vicinity of the site may be comprised of clay, silt, till, sand and gravel overlying pre-glacial to glacial bedrock; glacio-lacustrine deposits are also present on the left bank (KCB-SLI, 2014). Construction work is located on flat land where the potential for run-off erosion is minimal, but also on moderate and steep slopes where the potential for run-off erosion is significant.

4.3 Erosion and Sedimentation Control Measures

ESC measures identified for various construction activities are outlined in Table 4-1 and Table 4-2.

Table 4-1 Suitability of ESC Practices for Various Construction Activities

BMP	Activity								
	Clearing & Grubbing	Stripping & Grading	Borrow Areas	Excavation	Stockpiles	Slopes	Roads	Stormwater Conveyance	Landscape Restoration
Stripping, Grading and Site Preparation									
1. Construction Scheduling and Phasing	✓	✓		✓	✓	✓	✓	✓	✓
2. Preserve Existing Vegetation	✓	✓				✓		✓	✓
3. Surface Grading, Roughening & Texturing		✓		✓	✓	✓		✓	✓
4. Topsoil Salvage & Placement	✓	✓	✓	✓	✓	✓		✓	✓
5. Stabilized Construction Exits	✓	✓	✓	✓	✓		✓		✓
Erosion Control: Stormwater Management									
6. Temporary Berms and Diversion Channels	✓	✓		✓	✓	✓	✓	✓	✓
7. Grass-Lined Channels		✓					✓	✓	✓
8. Riprap-Lined Channels		✓		✓			✓	✓	✓
9. Temporary Slope Drains		✓				✓	✓	✓	✓
10. Energy Dissipaters		✓		✓			✓	✓	✓
11. Check Dams		✓					✓	✓	✓
Erosion Control: Temporary Soil Stabilization									

BMP	Clearing & Grubbing	Stripping & Grading	Borrow Areas	Excavation	Stockpiles	Slopes	Roads	Stormwater Conveyance	Landscape Restoration
12. Seeding and Sod			✓		✓	✓	✓	✓	✓
13. Mulching	✓	✓	✓		✓	✓	✓	✓	✓
14. Hydromulching & Hydroseeding			✓			✓	✓	✓	✓
15. Rolled Erosion Control Products			✓			✓	✓	✓	✓
16. Compost Blankets						✓	✓	✓	✓
17. Straw/Fibre Wattles		✓	✓		✓	✓	✓	✓	✓
18. Riprap				✓		✓	✓	✓	✓
Sediment Control									
19. Dust Control	✓	✓	✓	✓	✓	✓	✓	✓	✓
20. Construction Drainage & Dewatering		✓		✓			✓	✓	
21. Sediment Traps & Basins	✓	✓	✓	✓			✓	✓	
22. Compost Berms and Socks		✓	✓	✓	✓	✓	✓		
23. Silt Fence	✓	✓	✓		✓	✓	✓		✓
24. Flocculants & Coagulants		✓	✓	✓	✓	✓	✓	✓	

Best management practices (BMPs) related to installation, inspection, maintenance, and removal of the ESC measures identified are contained in Appendix A. The BMPs presented in Appendix A are considered to be consistent with standard ESC practices adopted across North America and are considered to be sufficient in scope for this application. The BMPs are generic in nature and are intended to provide general guidance for potential ESC scenarios and for the development of EPPs.

Table 4-2 Application of Best Management Practices

BMP	APPLICATIONS	COMMENTS	
		ADVANTAGES	CHALLENGES/LIMITATIONS
BMP 1: Construction Scheduling and Phasing	<ul style="list-style-type: none"> • Protect slopes • Protect vegetation • Ditches/Channels • Large, flat areas • Borrow/stockpiling • Site roads • Protect site perimeter • Protect adjacent areas 	<ul style="list-style-type: none"> • Requires the proper selection and timely implementation of ESC practices prior to the start of construction. • Timely, effective sourcing, procurement and delivery of ESC supplies to the site. • Avoids/reduces the need to reactively respond to ESC problems, thereby reducing potential damage, cost over-runs and enforcement. 	<ul style="list-style-type: none"> • Scheduling and phasing uncertainty increases with project size, duration and complexity. Effectiveness is likely to vary as projects proceed. • Still depends on proper implementation, inspection and maintenance of ESC practices. • Requires frequent re-assessment and modification.
BMP 2: Preserving Existing Vegetation	<ul style="list-style-type: none"> • Protect slopes • Protect water bodies • Protect trees • Protect sensitive vegetation and habitat • Protect site perimeter • Combine with BMP 1 	<ul style="list-style-type: none"> • Far more effective than all other ESC measures. • Native vegetation is adapted to the site, drought tolerant, and will provide shade and erosion protection. • Buffer strips around the perimeter of a site can reduce or eliminate off-site sedimentation. • Especially suitable to multi-year projects where stripping and grading can be phased. 	<ul style="list-style-type: none"> • For sites with diverse topography, it is often difficult and expensive to save existing vegetation due to significant site grading.
BMP 3: Surface Grading, Roughening and Slope Texturing	<ul style="list-style-type: none"> • Exposed soils on disturbed slopes • Large stockpiles • Following topsoiling • Prior to seeding • Ripping/furrowing of flatter stripped areas along the contour reduces erosion caused by run-off and wind 	<ul style="list-style-type: none"> • Decreases run-off velocity and surface wind speed (decreased erosion potential). • Increases infiltration. • Traps and retains sediment and seed detached by water and/or wind. • Provides beneficial 'seedling-safe' sites for germination/establishment of seedlings. • Enhances the performance of topsoiling, mulching and hydroseeding. 	<ul style="list-style-type: none"> • Generally impractical for short slopes, very steep slopes or non-cohesive soils. • May cause water build-up and sloughing in wet/seepage areas. • Provides short-term benefit (may need re-done) and works best when used as part of a system of practices. • Grading costs are increased. • Long term maintenance requirements (such as mowing) may limit the choice of suitable texturing methods.

BMP	APPLICATIONS	COMMENTS	
		ADVANTAGES	CHALLENGES/LIMITATIONS
BMP 4: Topsoil Salvage and Placement	<ul style="list-style-type: none"> • Preserve soil seed bank and biological, chemical and physical integrity • Ensure timely application of topsoil to slopes and large flat areas immediately following final grading • Ditches/channels 	<ul style="list-style-type: none"> • Useful where it is desirable to establish native plants and indigenous grasses from seeds “banked” in the topsoil. • Placing topsoil provides an enriched organic medium and nutrients for plant development. • Topsoil absorbs raindrop energy and promotes infiltration (reduced erosion potential). • Stabilized topsoil stockpiles can help shield adjacent areas from the construction site and reduce dust and noise. 	<ul style="list-style-type: none"> • Avoid contamination with subsoil (successful topsoil stripping on large sites requires soil survey information showing topsoil locations and depth. • Topsoil must not be applied to frozen or saturated subsoil. Subsoil often needs to be scarified prior to topsoil placement. • Topsoil application on slopes steeper than 2H:1V requires installation of additional erosion controls (such as rolled erosion control products).
BMP 5: Stabilized Construction Site Exits/Entrances	<ul style="list-style-type: none"> • All construction site access/exit points 	<ul style="list-style-type: none"> • When used in combination with regular inspection and cleaning of adjacent streets, this practice reduces the off-site deposit of sediment onto public roads and into storm sewer catch-basins. 	<ul style="list-style-type: none"> • May be limited by space constraints. • Require frequent inspection and maintenance (especially during wet conditions or clayey soils). • In some cases (wet or soft soils), gravel/rock must be placed on geotextile to prevent ‘punching’ of material into ground. • Requires regular inspection and cleaning of adjacent public streets. • May also require a vehicle wash station.

BMP	APPLICATIONS	COMMENTS	
		ADVANTAGES	CHALLENGES/LIMITATIONS
<p>BMP 6: Temporary Diversion Berms and Swales</p>	<ul style="list-style-type: none"> To contain and divert clean run-off away from disturbed soils. To contain and divert sediment-laden run-off to sediment controls. To protect adjacent property, buildings and structures from flooding. Used in conjunction with slope drains. 	<ul style="list-style-type: none"> Minimizes erosion caused by excessive sheet flow over exposed slopes. Simulate natural flow conditions more than paved or enclosed stormwater conveyances. Open channels are usually less expensive to construct than other types of conveyance. Open channels are easy to inspect and maintain. 	<ul style="list-style-type: none"> Channels may have to be lined to minimize erosion. Channels must be designed by a geotechnical engineer/hydrologist if flow velocities and/or volumes are large. Berms greater than 1 m in height should be designed by a geotechnical engineer. The consequences of failure must be considered. Channels must be located on stable slopes and must maintain positive drainage to avoid water ponding and breaching. May need to remove accumulated sediment from channel.
<p>BMP 7: Grassed/ Vegetated Channels</p>	<ul style="list-style-type: none"> Suitable for channels with maximum grade $\leq 5\%$. Construct at 2 – 5% grade to convey drainage at low velocities. 	<ul style="list-style-type: none"> Resemble natural channels and should be the preferred option where low gradients and design velocities are possible. Generally less expensive to install than curb, gutter and underground storm drainage. Relatively easy to construct. Provide reduced flow volume by allowing infiltration and reduce outlet velocities by providing surface roughness. Can provide some pre-treatment of run-off prior to discharge to another treatment system. 	<ul style="list-style-type: none"> Vegetation establishment can be slow in northern climates: Additional temporary stabilization measures may be required. Vegetation will not survive in sections of channels subject to sustained flow. Soils should be suitable to establish a vigorous stand of vegetation. If dense vegetation cannot be maintained in the swale, its effectiveness will be severely reduced. Channel excavation will produce a significant amount of spoil material.

BMP	APPLICATIONS	COMMENTS	
		ADVANTAGES	CHALLENGES/LIMITATIONS
BMP 8: Riprap-Lined Channels	<ul style="list-style-type: none"> • Generally used as a permanent erosion control measure for channels. • Riprap or similar linings can be installed relatively easily using heavy construction equipment. • Channels with highly erodible soils on gradients > 2% and flow velocities ranging from 2 – 5 m/s). 	<ul style="list-style-type: none"> • Permanent erosion control. • Can provide a durable, flexible and low maintenance erosion resistant lining. 	<ul style="list-style-type: none"> • Generally needs to be designed and specified by a qualified professional. • Riprap or similar linings are expensive (dependent on rock size, local availability, transportation and handling costs). • Channel/ditch must be excavated and prepared prior to riprap placement (this includes over excavation of the channel to accommodate the required riprap thickness and the disposal or excavated spoil). • Always require the replacement of an extra-strength, non-woven filter fabric or a gravel blanket underlay to prevent the entrainment and displacement of erodible material from the underlying soil layer.
BMP 9: Temporary Slope Drains	<ul style="list-style-type: none"> • Cut or fill slopes: Where concentrated run-off that collects above a cut or fill slope - and cannot otherwise be conveyed around the slope - would cause severe erosion if it spilled over the slope. 	<ul style="list-style-type: none"> • Allows temporary conveyance of concentrated run-off down a cut or fill slope without causing erosion. 	<ul style="list-style-type: none"> • Proper sizing, installation and maintenance is critical to ensure function until permanent conveyance is installed or the slope is stabilized. • Serious scour erosion can occur at the inlet structure if not properly installed and maintained (can cause slope drain failure). • Outlet must have adequate energy dissipation to prevent erosion.
BMP 10: Energy Dissipaters/Outlet Erosion Control	<ul style="list-style-type: none"> • At outlets where concentrated run-off transitions to an erodible area. • At inlets, to prevent scour erosion. • In channels, to reduce scouring. 	<ul style="list-style-type: none"> • Utilizes a non-erodible, rough surface to dissipate the energy of flowing water, thereby reducing erosion. • Only requires a small area for construction. • Riprap aprons are relatively easy and inexpensive to construct. 	<ul style="list-style-type: none"> • Adequate sized material is required to handle high flow conditions. • Many dissipaters can be expensive and labour- intensive to construct. • Extreme discharge velocities require design by a qualified professional.

BMP	APPLICATIONS	COMMENTS	
		ADVANTAGES	CHALLENGES/LIMITATIONS
BMP 11: Check Dams	<ul style="list-style-type: none"> • Temporary or permanent erosion control practice in channels. • Only suitable for channels subject to periodic flow. • May provide some limited sediment control (ponding and settling of coarse sediment) behind the structure. Note that check dams should primarily be used for erosion control and channel grade control, not sediment control. • NOTE: Straw bales and silt fence do not work. Do not use silt fence in concentrated flows. 	<ul style="list-style-type: none"> • Reduce flow velocities in channels (erosion control). • Flatten the effective channel grade. 	<ul style="list-style-type: none"> • Permanent check dams may obstruct ditch maintenance activities (i.e. mowing). • Should withstand displacement at high flows. • Rock checks restricted to ditch gradients less than 8%, flow velocities less than 1.5 m/sec and drainage areas less than 4 ha. • For high flows, water should be able to flow over (not around) check dams. • Silt fence and straw bales are <u>not</u> suitable for use as check dams. • Provide minimal sediment control. • Creation of turbulence downstream can cause erosion of the channel banks/base. • Pondered water may kill grass in grass-lined channels. • Synthetic barriers can become brittle in winter and be damaged by snow or traffic.

BMP	APPLICATIONS	COMMENTS	
		ADVANTAGES	CHALLENGES/LIMITATIONS
BMP 12: Seeding (temporary and permanent) and Sod	<ul style="list-style-type: none"> • Important component of “phased” construction activities. • Temporary seeding is suitable for some interim areas requiring temporary erosion control (i.e. topsoil stockpiles, rough graded areas, berms). • Permanent seeding is suitable for areas which have been graded to final contour, prepared and topsoiled. • In combination with mulches, RECPs, compost or other erosion controls. 	<ul style="list-style-type: none"> • Vegetation cover on exposed soils helps protect soil from erosion by raindrop impact, increases infiltration and reduces run-off. • Temporary seeding can reduce maintenance costs for other site controls (i.e. sediment traps). • Protects integrity of temporary earthen structures (i.e. diversion and containment berms, compost berms). • Complements other erosion control measures such as RECPs and roughening. • Relatively low cost compared to other ESC measures. • A variety of techniques are available for seed application, depending on-site conditions. 	<ul style="list-style-type: none"> • Seasonal planting windows may not coincide with the construction schedule. • Not appropriate for areas subject to construction traffic. • May require additional erosion control measures and irrigation during seedling establishment. • Vegetation may require regular maintenance. • Reseeding and amendments may be required. • Requires the application of a suitable seed mix at optimum rates.
BMP 13: Mulching	<ul style="list-style-type: none"> • Generally used to provide temporary stabilization of soil, usually until permanent stabilizing vegetation is established. 	<ul style="list-style-type: none"> • Mulch provides effective short term erosion control and can enhance soil temperature and moisture conditions for seedling establishment. • Mulching reduces soil particle detachment, run-off velocity, soil compaction and crusting, and can increase infiltration. 	<ul style="list-style-type: none"> • Most mulches are limited to providing temporary erosion control. • Mulches need to be anchored on steep slopes or in windy conditions. • Best used in combination with vegetation for long- term erosion control. • Mulch type and availability will vary by location. • Some mulches prevent plant establishment.

BMP	APPLICATIONS	COMMENTS	
		ADVANTAGES	CHALLENGES/LIMITATIONS
BMP 14: Hydromulching and Hydroseeding	<ul style="list-style-type: none"> • <u>Hydromulching</u>: suitable for application of mulch (typically wood or paper fibre). • <u>Hydroseeding</u>: suitable for rapid application of mulch, tackifiers and other specialized soil amendments. 	<ul style="list-style-type: none"> • A cost effective method of uniformly applying multiple materials (seed, fertilizer, mulch, tackifier) in one application to large areas (especially steep slopes and difficult terrain). 	<ul style="list-style-type: none"> • Can be expensive, so is generally limited to large areas and steep slopes. • Requires the use of specialized equipment to mix and apply slurry. • Subsequent applications may be required to maintain mulch cover and/or where seed germination is poor. • On rough sites, seed can be caught up in mulch and desiccate (consider applying seed first).
BMP 15: Rolled Erosion Control Products (Blankets and Mats)	<ul style="list-style-type: none"> • Suitable for application on steep slopes to complement vegetation establishment. • Some heavier duty erosion control blankets and synthetic turf reinforcement mats are suitable for use in channels (subject to design velocities and shear resistance). 	<ul style="list-style-type: none"> • Several categories and types of RECPs for a variety of site conditions/applications. • Some software programs have been developed to assist with RECP selection. • Can be a temporary or permanent measure (depending on the RECP selected). • Provide immediate protection of erodible soils on cut/fill slopes at 3H:1V or steeper. • Protection of exposed soils in ditches and channels (with water velocities of 1 - 2 m/s) by providing additional shear resistance in conjunction with well-established vegetation cover (TRMs/C-TRMs). • Useful for medium-term erosion protection on soils exposed outside of a vegetation establishment window. • On disturbed slopes adjacent to water bodies or environmentally sensitive areas. 	<ul style="list-style-type: none"> • Long-term erosion control still requires establishment of vegetation. • Poor selection or installation is a common cause of failure. • Some site preparation is required prior to installation. • Product and installation costs can make RECPs expensive. Manufacturers are developing new equipment to speed installation time. • Ensure only biodegradable or open weave netting is used for application in natural areas, wildlife corridors or adjacent to water bodies.

BMP	APPLICATIONS	COMMENTS	
		ADVANTAGES	CHALLENGES/LIMITATIONS
BMP 16: Compost Blankets	<ul style="list-style-type: none"> • Suitable for slopes 2H:1V or flatter, but can be combined with additional practices such as compost berms or compost socks to treat slopes as steep as 1H:1V. • Should not be applied in areas subjected to concentrated run-off. • A specified seed mix is usually incorporated with compost during application. 	<ul style="list-style-type: none"> • Compost is organic, biodegradable and renewable. • Compost retains a large volume of water and can promote infiltration and vegetation establishment (reduced run-off and erosion). • Erosion control composts have a well-graded mixture of particle sizes: Compost blankets form a strong, three-dimensional protective soil cover and compost berms and socks are effective at filtering out suspended solids from sediment-laden run-off. • Beneficial micro-organisms and organic matter promote the vigorous establishment of vegetation, as well as biodegradation of stormwater contaminants. • When a pneumatic blower truck is utilized, a specified seed mix and rate can be incorporated with the application. 	<ul style="list-style-type: none"> • In some areas, economical supply of suitable compost for erosion control may be limited. • Compost quality and screen size is important. A well-graded mixture of coarse and fine particles is desirable for ESC applications. • To prevent water from sheeting between the compost blanket material and soil surface on a slope, a minimum 1 m wide band of blanket material should be installed on the shoulder of the slope. Alternatively, a compost berm or filter sock may be placed at the top of the slope.
BMP 17: Straw/Fibre Wattles (Rolls)	<ul style="list-style-type: none"> • As a temporary grade break on exposed slopes and grades. 	<ul style="list-style-type: none"> • Wattles and fibre rolls provide grade breaks and reduce erosion by decreasing run-off velocity and rill formation on exposed slopes. • Can trap seed, organic matter and sediment washed down slope. • Wattles break down over time (no removal cost). 	<ul style="list-style-type: none"> • Only suitable for temporary erosion control (vegetation provides long term erosion control). • Requires proper installation (entrench, stake and overlap ends) to prevent undermining. Installation can be expensive (hand labour). • Not suitable for concentrated run-off.

BMP	APPLICATIONS	COMMENTS	
		ADVANTAGES	CHALLENGES/LIMITATIONS
BMP 18: Riprap	<ul style="list-style-type: none"> On cut/fill slopes subject to seepage, weathering and/or significant erosion, particularly where conditions prohibit establishment of vegetation. On channel side slopes and bases. As an inlet/outlet energy dissipater and on steep sections of bridge abutments. For riverbanks subject to wave and flow action. 	<ul style="list-style-type: none"> Riprap is flexible (can adjust to changes resulting from settling or erosion beneath the stone). The rough surface of riprap provides good energy dissipation in flowing water. Durable, low maintenance and easy to install and repair. 	<ul style="list-style-type: none"> Requires a non-woven geotextile underlay or gravel blanket underlay to prevent erosion of underlying soil. Requires design by a qualified professional. Expensive, subject to availability and requires heavy equipment for transportation and placement. For equivalent protection to a gabion mattress, open riprap typically needs to be placed at 2 – 3 times the thickness.
BMP 19: Dust Control	<ul style="list-style-type: none"> Dust control measures should be applied to large areas of exposed soil, especially sub soils that are disturbed and prone to drying out. Dust control measures should also be applied to stockpiles, haul roads and other disturbed areas exposed to wind. 	<ul style="list-style-type: none"> The timely implementation and frequent inspection and maintenance of practices used to control dust can significantly improve the health and safety of construction workers and the general public. 	<ul style="list-style-type: none"> Water or chemical dust suppressants may need frequent re-application, especially in dry, windy conditions or in areas under heavy disturbance. Ensure chemical dust suppressants are appropriate for use and environmentally benign. Always obtain and adhere to product Material Safety Data Sheets.

BMP	APPLICATIONS	COMMENTS	
		ADVANTAGES	CHALLENGES/LIMITATIONS
BMP 20: Construction Dewatering	<ul style="list-style-type: none"> Construction dewatering refers to the removal of impounded storm run-off or groundwater from a construction site (i.e. excavations, coffer dams, sediment traps and basins). Strict conditions on the quality, rate and volume of the discharge may be required. This generally requires that best practices are implemented to control sediment and other contaminants. 	<ul style="list-style-type: none"> Construction dewatering is generally intended to regain access to excavations impacted by storm run-off or groundwater seepage. Forecasting and planning for dewatering can reduce project delays and ensure compliance with regulations. Dewatering of sediment traps and basins (via a suitable outlet structure or by pumping) is sometimes required to provide access for sediment removal and to maintain required storage volume. Dewatering of excavations and areas with ponded water can improve site safety and reduce mosquito breeding. 	<ul style="list-style-type: none"> Consultants and contractors should be familiar with dewatering best practices and may often need to apply a combination of source controls and sediment controls (treatment train) to be effective. Many dewatering controls only address sediment and not other contaminants such as metals and hydrocarbons. In many cases, detailed information on-site history and baseline water quality is essential. Fine sediment is very difficult to filter or settle using conventional means and is best controlled at the source. It may be necessary to use suitable flocculants or coagulants to promote settling of fine silt and clay-size material.

BMP	APPLICATIONS	COMMENTS	
		ADVANTAGES	CHALLENGES/LIMITATIONS
<p>BMP 21: Sediment traps and basins</p>	<ul style="list-style-type: none"> Installed at the site perimeter, as well as intermediate points, to retain concentrated, sediment-laden run-off. Sediment basins are suitable for disturbed drainage areas greater than 2.0 ha. Sediment traps are suitable for disturbed drainage areas of ≤ 2.0 ha 	<ul style="list-style-type: none"> Depending on upstream soil texture, and if properly designed, installed and maintained, traps and basins can remove 70% – 80 % of the sediment from detained run-off. The use of a skimmer device connected to an outlet improves sediment-trapping efficiency by better regulating the filling and draining of a basin. 	<ul style="list-style-type: none"> Basins should be designed by a qualified professional. 100% sediment removal effectiveness is not possible, especially for silt and clay-sized material. Should be used as a complement to run-off and erosion control. Should be frequently inspected and maintained to ensure effectiveness. It may be necessary to conduct approved dewatering of the structure or to design more detention than retention (i.e. device or outlet for slowly draining the structure). Traps must <u>not</u> be located in live streams. Periodic removal of accumulated sediment is required.

BMP	APPLICATIONS	COMMENTS	
		ADVANTAGES	CHALLENGES/LIMITATIONS
<p>BMP 22: Compost Berms and Compost Filter Socks</p>	<ul style="list-style-type: none"> • Berms/socks can be installed at the base of slopes with gradients of 2H:1V or less (for steep slopes, berms/socks can also be installed, on contour, to reduce slope length). • Berms/socks must be installed perpendicular to sheet flow, allowing run-off to be intercepted, detained and filtered. Filter socks can be staked in channels (as temporary check dams) to reduce the velocity of low to moderate flows (control channel erosion). 	<ul style="list-style-type: none"> • A suitable seed mix can be incorporated into berms and socks during construction. • Filter socks are flexible and can be filled in place or filled and moved into position. • A range of biodegradable and synthetic mesh casing is available for compost socks. Casing provides added structural stability and integrity to the compost, allowing application for areas such as steeper slopes, low flow channels and for stream bank/shoreline bioengineering projects. • Compost is organic, biodegradable, renewable, and can be left onsite. • The flexibility, continuity and weight of berms and filter socks allows for good conformity and surface contact with site soils, reducing potential for undermining. • Installation does not require disturbing the soil surface. • Compost retains a large volume of water (reduced erosion potential, enhanced seedling establishment). • Compost berms and socks are more effective at providing filtration of sediment-laden run-off than traditional controls such as silt. • Compost can adsorb stormwater contaminants such as heavy metals, nutrients, pesticides and hydrocarbons. 	<ul style="list-style-type: none"> • Only suitable for detention and filtration of sheet run-off or (for socks) low to moderate channel flow. • Use only sanitized, mature compost that meets all local, provincial and federal (CCME Category A) requirements. • To maximize effective filtration, compost should consist of both large and small fragments. • Compost must be free of weeds, weed seeds, pesticide residues and garbage.

BMP	APPLICATIONS	COMMENTS	
		ADVANTAGES	CHALLENGES/LIMITATIONS
BMP 23: Silt Fence	<ul style="list-style-type: none"> Silt fence is installed along contours and in “smile” and “J-hook” patterns designed to detain sediment-laden <u>sheet flow</u> from small, disturbed areas. Silt fence is most effective for trapping larger particle sizes (coarse silt to sand): Finer-size material (fine silt and clay-size) is <u>not</u> detained. Silt fence is a suitable practice for the toe of short, exposed cut and fill slopes, as a <u>contour</u> boundary between a construction site and critical areas such as environmentally sensitive areas and as a stockpile perimeter control. Clean run-off must be diverted away from sediment containment controls such as silt fence. 	<ul style="list-style-type: none"> In combination with upstream erosion and run-off controls, silt fence can be an effective way to capture and settle coarse sediment from <u>small areas subject to sheet flow</u>. Silt fences generally have a useful life of up to one season (dependent on the amount of maintenance required). 	<ul style="list-style-type: none"> Improper silt fence installation, inspection and maintenance can increase erosion. As a temporary practice, silt fence should be removed when the contributing area is stabilized. Silt fence should be considered, wherever possible, as a “last line of defence”. There is no substitute for controlling upstream run-off and erosion. Long, continuous runs of fence concentrate run-off and commonly lead to failures. Do not install silt fence at locations where concentrated run-off occurs or may occur. Silt fence is not effective unless properly sliced or entrenched and compacted into the ground. Silt fence should not be designed to impound sediment or water more than 0.5 m high. Silt fence does a poor job of controlling clay and fine silt in sediment-laden run-off: Run-off is usually not detained long enough to allow settling of fine soil particles. Do not place silt fence on a slope. Unless intended as a diversion. Ensure the maximum area draining to silt fence is 0.1 ha per 30 m of fence (or less for fence at the toe of steep slopes).

BMP	APPLICATIONS	COMMENTS	
		ADVANTAGES	CHALLENGES/LIMITATIONS
<p>BMP 24: Flocculants and Coagulants</p> <p><u>Note:</u> This BMP discusses two categories of chemicals that are available: Chitosan and anionic polyacrylamide (PAM). The advice of manufacturers, suppliers, sediment control specialists and regulators should be sought prior to using chemicals for sediment control.</p>	<ul style="list-style-type: none"> Chitosan is commonly used as a coagulant in long-term construction dewatering activities (to complement other dewatering practices when fine silt and clay-size material is unavoidably suspended in water). Anionic PAMs are intended for use on soils that contain high amounts of fine silt and clay-size material. PAMs can be soil applied (to improve soil structure and reduce erosion by wind or water) or to treat sediment-laden water upstream of retention or detention controls. Anionic PAMs complement the use of other ESC practices when the timely establishment of vegetation may not be feasible or adequate, or where conventional temporary ESC is limited. 	<ul style="list-style-type: none"> Chitosan and Anionic PAMs – selected on the basis of site-specific soil and water quality information and applied at low dosages - are non-toxic to aquatic life. Aggregation improves the resistance of fine-grained soils to particle detachment and entrainment by wind (dust control) and water, providing temporary protection for exposed soils prior to final stabilization. Aggregation of fine particles in fine grained size can increase soil pore volume and permeability. <i>In situ</i> flocculation or coagulation of fine silt and clay-size particles enhances particle settling and complements other sediment control practices. 	<ul style="list-style-type: none"> Note: Cationic PAM products must never be used as they are toxic to fish at extremely low levels (bind to fish gills and cause suffocation). Product effectiveness is affected by soil texture and – to a degree – soil chemistry: This requires site-specific soil information. This may limit product bulk ordering or reuse on multiple sites. Soil sampling and analysis may take several days to complete. Mechanical mixing or agitation is generally required after introduction of the product to water. May enhance precipitation of fine sediments in downstream sediment control structures, increasing maintenance requirements (removal of sediment). Over-dosage of product can cause dispersion of fine particles, negatively impacting soil structure and particle settling in water. Intended to complement conventional ESC practices: Not a substitute for timely planning and implementation of suitable ESC practices. Effectiveness of some products can be affected by temperature. The manufacturer should account for this when providing specific product and dosing rate recommendations.

4.4 ESC Measures

As outlined in Section 2.2, the Contractors are responsible for the design, installation, inspection, maintenance, and repair of all ESC measures until the final acceptance of the construction contract works. The Contractors shall follow the guidance in this plan when developing their site and schedule specific ESC plans. The Contractors' QP and / or Professional Engineers shall sign-off on any deviations from the Guidance in this Plan.

4.4.1 Construction Scheduling and Phasing

Well-planned construction phasing and scheduling can significantly reduce erosion and sedimentation potential by reducing the extent and duration of soil exposed to erosion by wind, rainfall, run-off, and vehicle tracking. The construction schedule should ensure that:

- All major construction/land disturbing activities and associated erosion and sediment control/stormwater management practices are identified.
- Scheduling and phasing reduces both the area of disturbed soils and the length of time disturbed soils are exposed to wind, rainfall, run-off and vehicle tracking (this includes considering the effect the time of year/season has on erosion potential). Wherever possible, scheduling should incorporate staged revegetation of slopes to reduce the length of time disturbed soils are exposed.
- The project complies with erosion and sediment control regulations, commitments and objectives, and that the Contractors are aware of compliance requirements and responsibilities.
- Contractors should plan the measures to be implemented prior to and/or during each stage of construction.
- The schedule is frequently reviewed throughout construction by the Contractors and modified, as required, to meet ESC objectives.

Details regarding the appropriate application, implementation and review of construction scheduling are contained in BMP 1 – Construction Scheduling and Phasing.

4.4.2 Preserve Existing Vegetation

Dense vegetation cover protects soil from raindrop impact and can typically reduce erosion rates by 98% compared to sites stripped of vegetation and topsoil. Existing native vegetation usually provides the best soil protection.

Recommended measures include:

- Only disturb areas immediately needed for construction to reduce exposure and sediment yield.
- Use buffer strips around water bodies and construction site perimeters to provide filtering of sediment from surface run-off.
- Protect riparian (adjacent to water bodies) vegetation and habitat during the planning and implementation of construction.

Details regarding the appropriate application, implementation, inspection and maintenance of buffer strips are contained in BMP 2 – Preserve Existing Vegetation.

4.4.3 Wetland Protection

Prior to commencement of construction in any given area, an appropriately qualified environmental professional should identify any wetland or other area of environmental significance that requires protection.

Silt fencing shall be installed to effectively protect any area of environmental significance subject to runoff from a disturbed area. Silt fencing should be continuous along all edges subject to runoff from disturbed areas. Silt fencing to be installed in accordance with BMP 23 – Silt Fence.

4.4.4 Surface Grading, Roughening & Texturing

Texturing exposed slopes and stripped/graded areas by installing tracks, grooves, furrows or benches that conform to contours helps interrupt the movement of sheet run-off across exposed areas, reducing effective slope lengths and decreasing potential for sheet and rill erosion.

Details regarding the appropriate application, installation, inspection and maintenance of surface grading are contained in BMP 3 – Surface Grading, Roughening and Slope Texturing.

4.4.5 Topsoil Salvage & Placement

The preservation and use of topsoil enhances final stabilization of construction sites with vegetation. The timely placement of topsoil over mineral soil can significantly reduce raindrop and sheet erosion potential and increase infiltration.

Details regarding the appropriate application, stockpiling, placement, inspection and maintenance of topsoil are contained in BMP 4 – Topsoil Salvage and Placement.

4.4.6 Stabilized Construction Exits

Site access/exit points should be stabilized so as to reduce the potential for vehicles to track sediment off site. Stabilization traditionally consists of application of a geotextile and gravel however gravel can be prone to tracking off-site, especially where large vehicles are leaving the site. Coarse woody slash material (such as chipped woody material from construction site clearing) offers a good alternative to gravel where rock is being tracked onto adjacent streets and roads. There are also manufactured portable products available for temporary construction entrance and exit control.

Tracking pads should be installed at all locations where vehicles enter or exit the construction site. In addition, it may be necessary to include a wash station with a water supply and wash water containment and detention for excessively muddy vehicles. When used in combination with regular inspection and cleaning of adjacent streets and roads (as necessary), this practice reduces the off-site deposit of sediment onto public roads and potentially into storm sewer catch basins.

Details regarding the appropriate implementation, inspection and maintenance of construction exits are contained in BMP 5 – Stabilized Construction Exits.

4.4.7 Stockpiles

In general, stockpiles should be located and protected as described in the CEMP. Best practice procedures for stockpiles include the following:

- Stockpiles are to be located in the designated stockpile areas, on flat terrain, at least 15 m from a watercourse.
- Stockpiles are to be typically surrounded by silt fencing to minimize the transport of sediment.
- Stockpiles are to be shaped to minimize potential erosion during extreme weather events.
- In the event of heavy snowmelt and heavy and/or prolonged rainfall that requires stockpiles to have additional stabilization, the Contractor's Environmental Monitor will implement more comprehensive erosion and sediment control measures. These control measures may include additional silt fencing, tackifier, texturing, plastic sheet or membrane covering. If plastic sheet covering is placed over an area it must be sufficiently anchored to resist wind.
- If soil or topsoil stockpiles are in place for typically more than 30 days they should be covered or stabilized with mulch and tackifier, vegetation or other suitable measure.

- Loose material (i.e., pit run gravel) should not be stockpiled at an angle greater than 3H:1V. If this is unavoidable, sandbags or gravel should be placed to stabilize the bottom perimeter of the pile to limit migration.

4.4.8 Drainage Channels

Drainage channels should be installed adjacent to all access roads, haul roads, and in any location required to control and direct stormwater runoff and avoid erosion.

In general, drainage channels should be installed as follows:

- Prior to constructing any drainage channel, a stabilized outlet should be constructed or ensure that run-off will flow to a naturally stabilized channel, sediment trap or basin.
- Typically construct drains from the bottom up, commencing at the stabilized outlet and working up the slope.
- Drains should be continuous, have a positive grade and drain towards a stabilized outlet.
- Temporary drainage channels should be designed to handle a 24 hour, 10 year storm.
- Drains should be armored against erosion with a suitable combination of seed, turf reinforcement mat, erosion control blanket, sediment logs, riprap, check dams or silt fencing.
- Exposed soil along ditch slopes should be horizontally tracked (refer to BMP 3).

For drains adjacent to roadways:

- A cross slope on the road surface should be provided directing runoff towards the adjacent drainage ditch.
- The drainage system should incorporate culverts and drain pipes where required to convey water beneath road surfaces and prevent localized ponding.

The drainage system shall be designed by a Qualified Professional and sized with consideration to catchment area, service life of the channel and expected rainfall events during the service life. The information contained in Table 4-3 may be used as a general guide for reference purposes.

Table 4-3 Suggested armouring of Drainage Channels

Grade	Drain type
1-2%	Grass lined swale with a horizontally tracked slope
> 2 %	Armour/stabilize the channel with material designed to withstand water velocity/shear (i.e. riprap, rolled erosion control blankets or vegetation)

4.4.8.1 Temporary Berms and Diversion Channels

Details regarding the appropriate application, design and construction of Temporary Berms and Diversion Channels are contained in BMP 6.

4.4.8.2 Grass-Lined Channels

Grass lined channels may be used to convey drainage at low velocities.

- The channel shape may be parabolic, trapezoidal, or V-shaped, depending on requirements.
- To aid in vegetation establishment and allow for maintenance, channel side slopes should be about 3H:1V or flatter.
- Late spring and summer are good times for construction of a grassed waterway as the soil can generally be easily worked and grass seed will catch easily. In areas with poor drainage, it will be necessary to work during a dry period.

Details regarding the appropriate application, design and construction of Grass-Lined Channels are contained in BMP 7.

4.4.9 Temporary Slopes

ESC measures on temporary slopes *that cannot be isolated from water courses through centralised drainage containment structures up to the design storm* (see Section 4.1) should be designed on a site specific basis with consideration to the slope, composition of exposed soil, proximity to the watercourse and other terrestrial areas, duration of exposure and the likely rainfall during the period of exposure.

- Silt fencing may be placed along the downslope edge of the work area to intercept overland runoff and prevent sediment from entering the watercourse. Alternately, the edge at watercourse may be maintained at a higher elevation.
- Water will not be used to flush sediment from the erosion and sediment controls.

- In the event of heavy snowmelt and heavy and/or prolonged rainfall or other weather that increases the potential for runoff and erosion, work should be discontinued.
- Slopes and soils prone to erosion should be stabilized as soon as practical. The slope can be temporarily protected by using straw wattle socks to break up the slope, in addition to the silt fence at the toe, if required.

Areas of disturbance should be revegetated with top soil and seed as soon as practical.

Table 4-4 may be used as a guide to indicate recommended ESC measures for temporary soil slopes.

Table 4-4 ESC Considerations on Temporary Soil Slopes

Slope	Service life	ESC Considerations
2H:1V or steeper	< 1 month	Hydroseed with tackifier Temporary slope drains Diversion berm along bottom of slope
	3 – 6 months	Hydroseed with tackifier Erosion Control Blanket Temporary slope drains Sediment logs at min. 10 m vertical centres Diversion berm along bottom of slope
	> 12 months	Hydroseed with tackifier Sediment logs at 5 m vertical centres Bench and berm at 10m vertical centre Diversion berm along bottom of slope
2H:1V to 3H:1V	< 1 month	Hydroseed with tackifier Temporary slope drains Silt fence along bottom of slope
	3 – 6 months	Hydroseed with tackifier Erosion Control Blanket Temporary slope drains Sediment logs at min. 10 m vertical centres Silt fence along bottom of slope
	> 12 months	Hydroseed with tackifier Sediment logs at 5 m vertical centres Silt fence along bottom of slope
< 3H:1V	< 1 month	Hydroseed with tackifier Temporary slope drains Sediment logs along bottom of slope

Slope	Service life	ESC Considerations
	3 – 6 months	Hydroseed with tackifier Temporary slope drains Sediment logs at min. 10 m vertical centres Silt fence along bottom of slope
	> 12 months	Hydroseed with tackifier Sediment logs at 5 m vertical centres Silt fence along bottom of slope

4.4.10 Temporary Slope Drains

A temporary slope drain is a heavy duty flexible tubing, pipe, over-side drain, or other conduit extending from the top to the bottom of a cut or fill slope. The drainage area may be used to provide indicative guidance regarding slope drain sizing. Indicative guidance regarding the minimum sizing for slope drains is contained in Table 4-5 however it should be noted that all temporary slope drains must be designed by a qualified professional to meet the requirements set out in the technical specifications. Details regarding the appropriate application, design and construction of Temporary Slope Drains are contained in BMP 9.

Table 4-5 Suggested Minimum Slope Drain Diameter Based on Contributing Area

Maximum Contributing Drainage Area (ha)	Minimum Pipe Diameter (mm, inside)
0.2	300
0.6	450
1.0	530
1.4	600
2.0	760

*Note: Table provided for information only: slope drain diameter must be designed by a qualified professional

4.4.11 Energy Dissipaters

Energy dissipaters are structures/hard armour placed at pipe outlets, in channels, and immediately downstream of check structures to reduce the velocity and dissipate the energy of concentrated water flow, thereby minimizing erosion and scour potential. Energy dissipaters can reduce flow energy in a relatively small area.

Details regarding the appropriate application, design and construction of Energy Dissipaters are contained in BMP 10.

4.4.12 Check Dams

Check dams may be used to prevent erosion in channels with a limited drainage area. Rock check dams are suitable for channels draining areas < 4 ha while other materials (sandbags, wattles, compost socks, and synthetic check dams) are suitable for channels draining areas < 2 ha. Silt fence may be used as an alternative to rock check dams in drainage swales with very low volume (flow velocity < 0.03 m/sec) with grades not exceeding 2% and contributing areas not exceeding 0.8 ha.

Check dams reduce erosion by decreasing the velocity of run-off in a channel and if properly installed and maintained, also provide temporary detention of run-off, allowing the settling of coarse sediment. Regular inspection and maintenance is required to remove sediment build up and prevent settled sediment from becoming subsequently re-suspended. Sediment behind check dams should be removed when it reaches 1/3rd the height of the centre elevation or as needed to prevent damage to channel vegetation while maintaining the effectiveness of the structure.

Guidance regarding the appropriate height and spacing of check dams is contained in Table 4-6. Details regarding the appropriate design, construction, inspection and maintenance of rock check dams and synthetic permeable barriers contained in BMP 11.

Table 4-6 Suggested Spacing for Check Dams

Ditch Grade	Minimum Weir Depth		
	150 mm	300 mm	450 mm
6 %	Not Recommended	4.5 m	7.5 m
5 %	Not Recommended	6.0 m	9.0 m
4 %	Not Recommended	7.5 m	12.0 m
3 %	4.5 m	10.5 m	15.0 m
2% or less	7.5 m	15.0 m	24.0 m

4.4.13 Seeding and Sodding

Seeding is the planting or placing of seed on disturbed soil after disturbed areas have been properly remediated and conditioned. Seeding can provide both temporary and permanent cover and the root structure will provide effective erosion control. Temporary seeding is used on suitable interim areas that are disturbed and require temporary protection. Temporary seeding is encouraged whenever possible to help reduce erosion on construction sites and is an important component of "phased" construction activities. Permanent seeding is applied to exposed areas which have been graded to final contour, prepared and topsoiled.

Grass sod can be used to immediately cover and stabilize exposed soil, allowing rapid establishment of vegetative cover where seeding is not practical. The use of sod is generally more expensive than seed however, it has an immediate effect. In addition to providing rapid erosion control, sod can also be used to provide a protective vegetated buffer adjacent to sensitive areas such as water bodies.

Details regarding the appropriate application, implementation, inspection and maintenance for seeding and sodding are contained in BMP 12.

4.4.14 Mulching

Mulching is the application of a protective layer of straw or other suitable material to exposed soil surfaces. Straw mulching and/or hydromulching is also used in conjunction with seeding and hydroseeding of critical areas to provide temporary erosion control and promote the establishment of vegetation. Mulching with straw or fiber mulches is also commonly used as a temporary measure to protect bare or disturbed soil areas that have not been seeded. In addition to absorbing raindrop impact and reducing soil erosion, suitable mulches can also help conserve soil moisture, moderate soil temperature, increase infiltration and protect seeds from predators, run-off and wind.

Details regarding the appropriate application, implementation, inspection and maintenance for mulching contained in BMP 13 - Mulching.

4.4.15 Hydromulching & Hydroseeding

Hydroseeders and hydromulchers can be used to uniformly broadcast seed, soil amendments, fibre mulch, and tackifiers, as a hydraulic slurry, onto the soil. Applying these materials as a water-based slurry can provide a cost effective means of erosion control and/or revegetation.

Hydraulically applied mulches form a continuous blanket on the soil surface, protecting the soil from raindrop impact and wind erosion, conserving soil moisture, reducing soil crusting and increasing infiltration. This results in improved conditions for seed germination and plant growth.

Details regarding the appropriate application, implementation, inspection and maintenance for hydroseeding and hydromulching are contained in BMP 14 – Hydromulching and Hydroseeding.

4.4.16 Rolled Erosion Control Products

Erosion control blankets are machine-produced mats of organic, biodegradable mulch such as straw, curled wood fibre (excelsior), coconut fibre or a combination thereof, evenly distributed on or between photodegradable polypropylene or biodegradable fibre netting.

Erosion control blankets can be used to provide immediate protection of erodible soils on slopes steeper than 3H:1V or steeper. They can also be used in conjunction with vegetation cover in ditches and channels to provide additional shear resistance for water velocities of 1 m/s to 2 m/s.

Details regarding the appropriate application, implementation, inspection and maintenance for erosion control blankets are contained in BMP 15 – Rolled Erosion Control Products.

4.4.17 Compost Blankets

Compost, applied as a blanket to an exposed slope, can significantly reduce raindrop, sheet, rill and gully erosion. Compost can also remove contaminants such as TSS, nutrients and metals from stormwater run-off. In many cases, compost blankets are more effective at promoting vegetation establishment, controlling erosion and suppressing weeds than Rolled Erosion Control Products or Hydroseeding. Compost blankets can be applied by hand on small areas, but are generally applied using a pneumatic blower truck.

Details regarding the appropriate application, implementation, inspection and maintenance for compost blankets are contained in BMP 16 – Compost Blankets.

4.4.18 Straw/Fibre Wattles

Straw/Fibre wattles consist of bundled straw (or other natural fibre) wrapped in photo-degradable open-weave plastic netting. Wattles are staked into the soil along slope contours using wood stakes or live willow stakes to provide a grade break. Wattles can also be used to retain sediment and seed washed downslope and retain moisture, promoting the growth of vegetation. Wattles are typically 200 mm diameter and are used on long, exposed slopes to reduce slope length, reduce rilling and decrease run-off velocity.

Details regarding the appropriate application, implementation, inspection and maintenance for straw/fibre wattles are contained in BMP 17 – Straw/Fibre Wattles.

4.4.19 Riprap

Riprap is a highly erosion resistant material that may be used to provide armouring to protect the soil surface from erosive forces and improve stability of soil slopes in drainage channels or on steep slopes. Riprap should be used in conjunction with a non-woven geotextile or gravel filter underlay to prevent soil movement into or through the riprap.

Riprap should:

- Consist of a graded mixture such that 50% of the mixture by weight is larger than the D_{50} size selected by the Qualified Professional. The largest rock size must be no more than 1-1/2 times the D_{50} size while the smallest size must be approximately 25 mm.
- The minimum thickness of the rip-rap layer should be 1-1/2 times the maximum stone diameter, but not less than 300 mm.
- Should be installed in one operation, immediately after the filter placement.

Riprap placement should be scheduled to occur immediately following disturbance and grading (i.e. for inlet or outlet protection, riprap should ideally be placed before run-off causes erosion).

Details regarding the appropriate design and installation of Riprap are contained in BMP 18.

4.4.20 Dust Control

Soil erosion by wind can be a significant problem when dealing with large areas of disturbed soil surfaces. Dust control is typically required to prevent wind transport of fine material—from disturbed soil surfaces onto roadways, drainage ways and into watercourses.

Liquid calcium chloride may be applied to road surfaces using a tank truck with a rear-mounted distribution bar that spreads the liquid evenly over the road surface. The liquid calcium chloride should be reapplied as directed by the Contractors' Environmental Monitor.

In the event of dry or windy conditions, a water truck may be used to spray the areas identified by the Contractors' Environmental Monitor. The water should be potable and free from suspended fine sediment. All haul routes should be treated for dust control and cleaned as necessary.

Details regarding the appropriate application and Implementation of Dust Control are contained in BMP 19.

4.4.21 Construction Drainage & Dewatering

Dewatering encompasses various methods used to remove and discharge excess water from a construction site. The most common method is to pump water out of areas where it does not otherwise drain off (i.e. excavations, sediment basins and traps). Water pumped out of cofferdams, excavations, footings and other areas where water can accumulate may contain high concentrations of suspended

solids. The solids are sometimes already suspended in the water, or construction or pumping activities can mix the solids into the water. In all cases, adequate sediment control (i.e. using diversion structures, well points, filter sump pits, sediment traps, sedimentation tanks, flocculants or coagulants) should be provided before the pumped water is discharged.

Construction dewatering for the Main Civil Works is to be conducted in accordance with the Care of Water Specification. Additional suggestions regarding the appropriate design, application and implementation of construction dewatering activities are contained in BMP 20.

4.4.22 Sediment Traps & Basins

Sediment traps and basins are sediment containment systems designed to contain, promote deposition of sediment laden run-off and to discharge water at a controlled rate. Traps or basins can be installed at the site perimeter, as well as intermediate points, to retain concentrated, sediment-laden run-off. Perimeter sediment containment should be installed prior to commencement of site stripping, grading and other earthwork.

To decrease sediment settling time, the controlled addition and mixing of an approved chemical flocculant may be considered. Excess flocculant must not be allowed to enter a watercourse. Only products that are proven to be non-toxic to fish and aquatic invertebrates may be used.

Details regarding the appropriate application, design and construction of Sediment Traps and Basins are contained in BMP 21.

4.4.23 Silt Fence

Silt fence is a permeable geotextile barrier installed vertically on support posts and entrenched in the ground. Silt fence is to be installed along contours and in “smile” and “J-hook” configurations designed to detain sediment-laden sheet flow from small, disturbed areas.

- Properly designed, installed sections of silt fence can capture sand and coarse silt-size particles.
- When used in combination with upstream erosion and run-off controls, silt fence can be an effective way to capture and settle coarse sediment from small areas subject to sheet flow.

The following guidelines should be noted when designing and installing Silt Fence:

- Contributing drainage area should not exceed about 0.1 ha per 30 m of fence.
- The run-off path length above a fence should not exceed about 30 m.

- Maximum slope gradient upstream of a fence should not exceed about 2H:1V.
- Unless intended as a temporary diversion structure, silt fence should be installed along a contour, with ends of the fence pointed upslope.
- Silt fence installed around a construction site perimeter should have a suitable number of J-hooks installed so that contributing drainage area is limited to about 0.1 ha per 30 m of silt fence.

Details regarding the appropriate application, design and construction of Silt Fencing are contained in BMP 23.

4.4.24 Flocculants & Coagulants

Low dosage of chemicals known as flocculants and coagulants may be used to promote aggregation and reduce settling time of fine sediment. Only products that are proven to be non-toxic to fish and aquatic invertebrates may be used.

Products should:

- Be environmentally benign, harmless to fish, aquatic organisms, wildlife, and plants.
- Be non-combustible.
- Not change soil or water pH.
- Be accompanied by MSDS and toxicity information from the manufacturer confirming that the product and any required additives cause no acute or chronic toxicity to aquatic biota.
- Be on the Canada Domestic Substances List (have a CAS registry # from Environment Canada). The manufacturer or supplier must be able to provide CAS numbers.
- Be accompanied written instructions from the manufacturer to ensure proper product selection, site preparation, application, inspection, maintenance, storage and safe use.

Details regarding the appropriate selection, application and implementation of Flocculants and Coagulants are contained in BMP 24.

5. ESC CONTROLS FOR PROJECT AREAS

5.1 General

5.1.1 Plan Scope

This section provides a high-level overview of the ESC measures suggested for the main construction areas of the site. This section does not include all areas of the site that will be covered in the Contractors' EPPs.

The measures identified in this section shall be considered in conjunction with the requirements set out in the CEMP, Water Management Plan for the RSEM areas (KCB-SLI, 2014), the relevant technical specifications and applicable permits and legislation. Where a Contractor identifies a conflict between this Plan's requirements and these other requirements it must notify BC Hydro and agree on a resolution to the conflict.

5.1.2 Applicable ESC Controls

Suggested applicable ESC measures for the entire project site areas are presented in Table 5-1. Additional details for specific phased construction areas are provided in the following Sections and represent the minimum suggested ESC measures. The ESC measures shall be adopted as required for other areas of the Project, as applicable where the soil and grade conditions are similar. The controls presented are suggested and may be adapted by the Contractor to suit the site conditions, time of year, and materials available. The Contractors' Qualified Professional and / or Professional engineer must review and approve all ESC Plans before construction of a project element commences. The ESC measures must be implemented under the direction of a Qualified Professional.

Table 5-1 Suggested ESC Measures by Area

BMP	Area	Left Bank Excavation	RSEM Area L3	RSEM Area L5	RSEM Area L6	RSEM Area R5a and R5b	RSEM Area R6	Road Construction	Rail Siding
Stripping, Grading and Site Preparation									
1. Construction Scheduling and Phasing		✓	✓	✓	✓	✓	✓	✓	✓
2. Preserve Existing Vegetation								✓	✓
3. Surface Grading, Roughening & Texturing		✓	✓	✓	✓	✓	✓	✓	✓
4. Topsoil Salvage & Placement		✓	✓	✓	✓	✓	✓	✓	✓
5. Stabilized Construction Exits								✓	✓
Erosion Control: Stormwater Management									
6. Temporary Berms and Diversion Channels		✓	✓	✓	✓	✓	✓	✓	✓
7. Grass-Lined Channels		✓	✓					✓	✓
8. Riprap-Lined Channels		✓	✓					✓	✓
9. Temporary Slope Drains		✓	✓	✓				✓	✓
10. Energy Dissipaters		✓	✓					✓	✓
11. Check Dams		✓	✓					✓	✓
Erosion Control: Temporary Soil Stabilization									
12. Seeding and Sod		✓						✓	✓
13. Mulching		✓						✓	✓
14. Hydromulching & Hydroseeding		✓	✓	✓	✓	✓	✓	✓	✓
15. Rolled Erosion Control Products		✓	✓					✓	✓
16. Compost Blankets		✓	✓		✓	✓	✓	✓	✓
17. Straw/Fibre Wattles		✓	✓	✓	✓	✓	✓	✓	✓
18. Riprap			✓					✓	✓
Sediment Control									
19. Dust Control		✓	✓	✓	✓	✓	✓	✓	✓
20. Construction Drainage & Dewatering		✓	✓	✓	✓	✓	✓	✓	✓
21. Sediment Traps & Basins		✓	✓	✓	✓	✓	✓	✓	✓
22. Compost Berms and Socks		✓	✓						
23. Silt Fence		✓	✓	✓	✓	✓	✓	✓	✓
24. Flocculants & Coagulants		✓	✓					✓	

5.2 Left Bank Excavation

5.2.1 Description

The Left Bank Excavation (LBE) is located on the North side of the Peace River where the centreline of the Dam connects into the natural terrain. There is minimal overland drainage area above the LBE. The works consist of exposing the final face of the LBE which will measure about 1000 m long by 300 m high. The final slopes will vary from near vertical at the base with about 2H:1V to 3H:1V slopes above.

5.2.2 ESC Considerations by Area and by Construction Phase

Table 5-2 provides a summary of the ESC considerations from project initiation through to projection closure for the LBE and is illustrated on Figure 1 and Figure 2.

Table 5-2 LBE ESC Measures

Construction Phase	Construction Activity	ESC Considerations
LBE Phase 1	<ul style="list-style-type: none"> Phase 1 is cleared to final grade exposing soils to potential mobilization. 	<ul style="list-style-type: none"> Top drainage ditch is installed across the top of the excavation footprint prior to the start of excavation to divert runoff away from the excavation (refer Drawing 1020-C18-0407). Flows should be managed to prevent point source erosion (BMP 6 – BMP11). During and after construction, where practical, runoff will be collected on a series of benches down the slope, graded to slope away from the face. The runoff may be collected in a series of sediment traps (BMP 21) that discharge into temporary slope drains (BMP 9) before discharging into the Peace River. Where contact water from active surfaces is not managed by downstream BMP's, sufficient sources controls, such as seeded compost blanket with tackifier (BMP 16) or sediment logs (BMP 17), must be provided to control contact water.
LBE Phase 2	<ul style="list-style-type: none"> Phase 2 is cleared to Final Grade down to anticipated bedrock elevation, exposing soils 	<ul style="list-style-type: none"> Surface water management for Phase 2 as per Phase 1. Phase 1 should be remediated to a final condition to minimize erosion.

Construction Phase	Construction Activity	ESC Considerations
	to potential mobilization.	
Cofferdam	<ul style="list-style-type: none"> Cofferdams are installed for construction of Left bank works. The base of the LBE is excavated lower than the Peace River water level. 	<ul style="list-style-type: none"> Surface water should be directed and managed at the base of the LBE behind the cofferdam. Water should be managed and pumped over the coffer dam to the Peace River from low lying groundwater and surface water sumps (BMP 20)
Restored Site	<ul style="list-style-type: none"> Dam Site is complete and construction activities have demobilised 	<ul style="list-style-type: none"> Exposed surface have been fully remediated and ESC measures are no longer required.

5.3 RSEM Area L3

Details regarding the water management requirements for RSEM Area L3 are provided in Section 7.2 of the Water Management Plan for the RSEM areas (KCB-SLI, 2014).

5.3.1 Description

RSEM Area L3 will be located in a forested, moderately incised tributary designated as “Unnamed Creek 3”, which flows into the left bank of the Peace River. The facility has been designed to hold material from the Left Bank Excavation and will have a maximum depth in the order of 40 m. It will be a valley fill with the toe located upstream of the confluence of Unnamed Creek 3 and a valley from the northeast. Additional works in the Unnamed Creek catchment area include the Worker Accommodations and Site Offices, laydown areas, construction of the North Bank Road, and the historic Howe Pit area.

5.3.2 ESC Considerations by Area and by Construction Phase

Table 5-3 provides a summary of the ESC considerations from project initiation through to projection closure for the RSEM area L3 and is illustrated on Figure 1 and Figure 3.

Table 5-3 RSEM AREA L3 ESC Measures

Construction Phase	Construction Activity	ESC Considerations
Site Preparation, North Bank Road Construction	<ul style="list-style-type: none"> Worker Accommodations and Site Offices, laydown areas, RSEM Area L3 and the North Bank Road construction areas are cleared, exposing soil to potential mobilisation. The construction of the North Bank Road culvert breaks the unnamed creek drainage path temporarily at the confluence of unnamed creek, a tributary to unnamed creek and the overland flow paths from the Worker Accommodations and Site Offices and laydown areas. Unnamed creek is reconstructed as a box culvert under the North Bank Road crossing. 	<ul style="list-style-type: none"> The upstream catchment area from L3-5 may be diverted around RSEM Areas L3 into a stilling basin (BMP 21). The stilling basin and flows from tributary to unnamed creek may be pumped around the North Bank Road construction into Unnamed Creek North Bank Road may utilize temporary berms and stilling basins (BMP 21) to capture water at temporary road ends. Water from temporary stilling basins may be pumped (BMP 20) to unnamed creek to maintain drainage. Where contact water from active surfaces is not managed by downstream BMP's, sufficient sources controls, such as seeded compost blanket with tackifer (BMP 16) or sediment logs (BMP 17), must be provided to control contact water.
Filling of RSEM Area L3	<ul style="list-style-type: none"> With the completion of North Bank road, the midpoint of Unnamed Creek is reinstated RSEM Area L3 is actively filled. 	<ul style="list-style-type: none"> North Bank road fill may be remediated with vegetation. Active surfaces may be graded towards temporary sediment ponds (BMP 21) where clean water may be discharged into unnamed creek.
Reclamation of RSEM Area L3	<ul style="list-style-type: none"> RSEM Area L3 reaches ultimate fill condition at the end of Diversion Stage 1 Worker Accommodations, Site Offices and construction lay down areas are 	<ul style="list-style-type: none"> With the completion of site, active surfaces may be vegetated to natural conditions. Flows from L3-5 may be reinstated across RSEM area L3. Sediment

Construction Phase	Construction Activity	ESC Considerations
	decommissioned with the completion of the Dam.	ponds may be reclaimed or maintained, as required, during the remediation process.
Reclaimed Unnamed Creek catchment	<ul style="list-style-type: none"> Vegetation in reclaimed areas is established. 	<ul style="list-style-type: none"> Temporary sediment ponds are decommissioned.

5.3.3 Howe Pit Reclamation

The south end of the Howe Pit contributes to Unnamed Creek. Historic rill erosion along the top of slope has occurred and runoff erosion may result in sediment transport downslope. This portion of the pit will not be used during construction of the Site C project and so reclamation of this area is recommended. A pit reclamation plan for this area should be developed.

5.4 RSEM Area L5

Details regarding the water management requirements for RSEM Area L5 are provided in Section 7.3 of the Water Management report for the RSEM areas (KCB-SLI, 2014).

5.4.1 Description

RSEM Area L5 is located on the left bank of the Peace River, just upstream of the Diversion Inlet and has a storage capacity of approximately 5.2 Mm³. The area will store material from the Left Bank Excavation, Diversion Inlet Portal, Diversion Tunnels and dam core trench excavations. It will be a valley side fill behind a dyke and will also extend into Garbage Creek (refer Drawing 1016-C11-00803).

During operation, RSEM Area L5 will be permanently submerged.

5.4.2 ESC Considerations by Area and by Construction Phase

Table 5-4 provides a summary of the ESC considerations from project initiation through to closure for the RSEM area L5 and is illustrated on Figure 1 and Figure 4.

Table 5-4 RSEM AREA L5 ESC Measures

Construction Phase	Construction Activity	ESC Considerations
Site Preparation	<ul style="list-style-type: none"> The lower portion of Garbage Creek 	<ul style="list-style-type: none"> Slopes may be capped as final grade is achieved.

Construction Phase	Construction Activity	ESC Considerations
	(L5-1) and the adjoining areas (L5-3) are cleared, exposing soil to potential mobilisation <ul style="list-style-type: none"> A starter dike is constructed along the edge of the Peace River 	<ul style="list-style-type: none"> The upstream catchment area of Garbage Creek (L5-2) is diverted around RSEM Areas L5 to the Peace River Water may be collected on the upslope edge of the starter dyke to collect and direct water to a sediment pond (BMP 21) before discharge into the Peace River. Where contact water from active surfaces is not managed by downstream BMP's, sufficient sources controls, such as seeded compost blanket with tackifier (BMP 16) or sediment logs (BMP 17), must be provided to control contact water.
Filling of RSEM Area L5	<ul style="list-style-type: none"> RSEM Area L5 receives material from other areas. 	<ul style="list-style-type: none"> Slopes may be capped as final grade is achieved. The active surface may be dyked to prevent overland flow into the Peace River. Flows may be directed towards a sediment pond (BMP 21) which is relocated as required to work with surface grading.
Stage 1 Diversion	<ul style="list-style-type: none"> Peace River rises to Stage 1 Diversion levels submerging the lower portions of RSEM Area L5 	<ul style="list-style-type: none"> Slopes may be capped as final grade is achieved. Collection ditch may be formed on the slope face of RSEM Area L5 above the Diversion Stage 2 Peace River water level to collect contact water and direct it to a sediment pond (BMP 21).
Stage 2 Diversion	<ul style="list-style-type: none"> Peace River Rises to Stage 2 Diversion levels submerging Lower levels of RSEM area L5. 	<ul style="list-style-type: none"> Slopes may be capped as final grade is achieved.
Reservoir Filling and Operation	<ul style="list-style-type: none"> RSEM Area L5 reaches ultimate fill condition. Reservoir is filled submerging remainder of RSEM area L5 	<ul style="list-style-type: none"> RSEM Area L5 will be permanently submerged and the surface of the RSEM between EL. 456.0 m and EL. 458.0 m will be covered to provide littoral fish habitat. Flows from Garbage Creek may be reinstated across RSEM area L5. Temporary Sediment ponds may be maintained or reclaimed, as required, during the remediation process.

Construction Phase	Construction Activity	ESC Considerations
Reclaimed L5 Area	<ul style="list-style-type: none"> Vegetation in reclaimed areas is established. 	<ul style="list-style-type: none"> With the establishment of vegetation across the site, sediment ponds will be decommissioned.

5.5 RSEM Area L6

5.5.1 Description

RSEM Area L6 has been designed to hold approximately 0.6 Mm³ of material from the Left Bank Excavation, Diversion Outlet and Tunnel excavation and is located downstream of the Diversion Outlet in the Left Bank flood plain of the Peace River (refer Drawing 1016-C11-00809). It will be a valley side fill between a starter dike and River Road.

5.5.2 ESC Considerations by Area and by Construction Phase

Table 5-5 provides a summary of the ESC considerations from project initiation through to projection closure for the RSEM area L6 and is illustrated on Figure 1 and Figure 5.

Table 5-5 RSEM AREA L6 ESC Measures

Construction Phase	Construction Activity	ESC Considerations
Site Preparation	<ul style="list-style-type: none"> RSEM Area L6 area is cleared exposing soil to potential mobilisation Starter dykes are established along the Peace River. 	<ul style="list-style-type: none"> Water may be collected against a berm constructed on the slope face of RSEM Area L6 to form a sediment pond (BMP 21) before discharge into the Peace River. Where contact water from active surfaces is not managed by downstream BMP's, sufficient sources controls, such as seeded compost blanket with tackifer (BMP 16) or sediment logs (BMP 17), must be provided to control contact water.
Filling of RSEM Area L6	<ul style="list-style-type: none"> RSEM Area L6 is filled with surplus material. 	<ul style="list-style-type: none"> As RSEM Area L6 is filled, the active surface may be dyked to prevent overland flow into the Peace River and the sediment pond is reinstated as required. The downslope portion of the fill draining to the Peace may be covered with a seeded compost blanket with tackifer (BMP 16) as final grade is achieved. Sediment logs (BMP 17) may be

Construction Phase	Construction Activity	ESC Considerations
		provided on the slope to control sheet runoff flows to minimise sediment mobilization.
Reclamation of RSEM Area L6	<ul style="list-style-type: none"> RSEM area L6 reaches its ultimate fill condition 	<ul style="list-style-type: none"> Temporary Sediment ponds will be maintained or reclaimed, as required, during reclamation.

5.6 RSEM Area R5a and R5b

Details regarding the water management requirements for RSEM Area R5a and R5b are provided in Section 7.5 and 7.6 respectively of the Water Management Plan for the RSEM areas (KCB-SLI, 2014).

5.6.1 Description

RSEM Area R5a and R5b are located along the Right Bank flood plain of the Peace River on either side of the confluence with Moberly River. R5a is on the upstream side and R5b the downstream side of the Moberly/Peace confluence (refer Drawing 1016-C11-00812). The area is forested and comprises the flood plain of the Peace River extending up the valley side slope. These facilities will store material from the Approach Channel, RCC Buttress, Dam Core Right Bank excavation, Powerhouse and Spillway excavations. It will be a valley side fill behind a starter dyke.

5.6.2 ESC Considerations by Area and by Construction Phase

Table 5-6 provides a summary of the ESC considerations from project initiation through to projection closure for the RSEM Area R5a and R5b are illustrated on Figure 1 and Figure 6.

Table 5-6 RSEM AREA R5a R5b ESC Measures

Construction Phase	Construction Activity	ESC Considerations
Site Preparation	<ul style="list-style-type: none"> RSEM Area R5a and R5b area is cleared exposing soil to potential mobilisation Starter dykes are established along the Peace River. 	<ul style="list-style-type: none"> Water from the disturbed areas will be collected against a berm constructed on the slope face of the RSEM areas to form a sediment pond (BMP 21) before discharge into the Peace River. Flows from the upland natural catchment area are captured and diverted to the RSEM areas sediment pond.

Construction Phase	Construction Activity	ESC Considerations
		<ul style="list-style-type: none"> Where contact water from active surfaces is not managed by downstream BMP's, sufficient sources controls, such as seeded compost blanket with tackifer (BMP 16) or sediment logs (BMP 17), must be provided to control contact water.
Filling of RSEM Area R5a	<ul style="list-style-type: none"> RSEM Area R5a and R5b are filled with surplus material. 	<ul style="list-style-type: none"> The active surface of the RSEM areas will be dyked to prevent overland flow into the Peace River and the sediment ponds are reinstated as required. The downslope portion of the RSEM areas draining to the Peace may be capped.
Stage 1 Diversion	<ul style="list-style-type: none"> Peace River rises to Stage 1 Diversion levels submerging the lower portions of RSEM's Area R5a to an elevation of 418.10 m (Max. design water level at inlet cofferdam) 	<ul style="list-style-type: none"> Collection ditch may be formed on the slope face of the RSEM areas above the Diversion Stage 2 Peace River water level to collect contact water and direct it to a sediment pond (BMP 21). The downslope portion of the RSEM areas draining to the Peace are capped.
Stage 2 Diversion	<ul style="list-style-type: none"> Peace River Rises to Stage 2 Diversion levels submerging Lower levels of RSEM area R5a. 	<ul style="list-style-type: none"> The downslope portion of the RSEM areas draining to the Peace may be capped.
Approach Channel Excavation	<ul style="list-style-type: none"> Excavation of the approach channel 	<ul style="list-style-type: none"> Where contact water from active surfaces is not managed by downstream BMP's, sufficient sources controls, such as seeded compost blanket with tackifer (BMP 16) or sediment logs (BMP 17), must be provided to control contact water.
Reclamation of RSEM Area R5a	<ul style="list-style-type: none"> RSEM Area R5a reaches ultimate fill condition. 	<ul style="list-style-type: none"> With the completion of site activities, RSEM Areas will be permanently submerged and the surface of the RSEM between El. 456.0 m and El. 458.0 m will be covered to provide littoral fish habitat.

Construction Phase	Construction Activity	ESC Considerations
		<ul style="list-style-type: none"> Overland flows from the upstream natural catchment will be reinstated into the Peace River. Temporary Sediment ponds will be maintained or reclaimed, as required, during the remediation process.

5.7 RSEM Area R6

Details regarding the water management requirements for RSEM Area R6 are provided in Sections 7.7 of the Water Management Plan for the RSEM areas (KCB-SLI, 2014).

5.7.1 Description

RSEM Area R6 has been designed to hold approximately 1.8 Mm³ of material from the Approach Channel, RCC Buttress, Dam Core right bank excavation, Powerhouse and Spillway, and is located downstream of the Site C dam in the Right Bank flood plain of the Peace River (refer Drawing 1016-C11-00818). It will be a valley side fill between a starter dike and the south river bank slope.

5.7.2 ESC Considerations by Area and by Construction Phase

Table 5-7 provides a summary of the ESC considerations from project initiation through to projection closure for the RSEM Area R6 and is illustrated on Figure 1 and Figure 7.

Table 5-7 RSEM Area R6 ESC Measures

Construction Phase	Construction Activity	ESC Considerations
Site Preparation	<ul style="list-style-type: none"> RSEM Area R6 area is cleared exposing soil to potential mobilisation Starter dykes are established along the Peace River. 	<ul style="list-style-type: none"> Runoff will be collected in a ditch formed on the upslope side of the dyke to attenuate flows and settle out TSS. Flows should be directed to a sediment pond (BMP 21) before discharge into the Peace River. Where contact water from active surfaces is not managed by downstream BMP's, sufficient sources controls, such as seeded compost blanket with tackifier (BMP 16) or sediment logs

Construction Phase	Construction Activity	ESC Considerations
		(BMP 17) , must be provided to control contact water.
Filling of RSEM Area R6	<ul style="list-style-type: none"> RSEM Area R6 are filled with surplus material. Tailrace and Buttress Excavation runoff and 25% dewatering flows from the Core Trench excavation are diverted to RSEM Area R6 	<ul style="list-style-type: none"> The active surface of the RSEM areas may be dyked to prevent overland flow into the Peace River and the sediment ponds are reinstated as required. The downslope portion of the RSEM area R6 draining to the Peace is capped.
Reclamation of RSEM Area R6	<ul style="list-style-type: none"> RSEM Area R6 reaches ultimate fill condition. 	<ul style="list-style-type: none"> Sediment ponds may be maintained or reclaimed, as required, during the remediation process.
Reclaimed R6 Area	<ul style="list-style-type: none"> Vegetation in reclaimed areas is established. 	<ul style="list-style-type: none"> With the establishment of vegetation across the site, sediment ponds will be decommissioned.

5.8 Road Construction

5.8.1 General

Site roads should be provided with surface-protected ditches on both sides of the road, where possible. Where the road grades are less than 2%, grass lined (hydro-seeded) ditches (BMP 7) with gravel check dams (BMP 11) are typically considered adequate. When the road grade exceeds 2%, riprap lined ditches (BMP 8) with rock check dams (BMP 11) are suggested. Centreline culverts should generally be provided as required with inlets and outlets protected with riprap aprons for example.

Where roads are to be constructed near wetland or archaeological zones, the protected areas should be isolated with silt fence (BMP 23).

5.8.2 North Bank Road

The western end of North Bank Road runs between RSEM Area L3 and the Worker Accommodations on the north side of the Peace River. The final road alignment will extend from Main Gate A, over the RSEM Area L3 drainage culvert to Main Gate B. North Bank Road is discontinuous over the RSEM Area L3 drainage culvert during construction of the culvert. Temporary water management infrastructure may be used to manage drainage at the temporary road ends until culvert construction is completed and the road alignment is brought up to grade. A temporary berm and **stilling basin (BMP 21)** may be required to capture water at

the temporary road ends. Water from the temporary stilling basins may then be **pumped (BMP 20)** to unnamed creek to maintain drainage.

5.8.3 River Road

River Road is located on the left bank of the Peace River and was constructed from gravel materials excavated from the river. The erosion potential of this area is considered to be low. The following ESC controls are suggested:

- The riverside edge of the road is protected with riprap. This edge should generally be maintained at a higher elevation than the rest of the road surface, both during construction and for final grading. Runoff flow from the road surface should be directed to a backslope ditch. Flow in the sloped portion of the ditch should be controlled with rock check dams (BMP 11) at approximately 15 m spacing. Enlarged ditch sections should be provided where topography allows to act as sediment traps (BMP 21). It is considered that water in the sediment trap will seep through the granular road base to the Peace River.

5.8.4 Septimus Road

Septimus Road extends from the lower terrace to the upper plateau of the right bank. On the terrace and the upper plateau the topography is generally flat lying with intermittent wetland areas. The erosion potential of this area is considered to be low. The road will traverse a relatively steep slope and the erosion potential of this area is considered moderate to high. The following ESC controls are suggested for the generally flat-lying areas:

- Any wetland areas identified as requiring protection should be isolated with silt fence (BMP 23) before any work commences.
- In the long-term, grass lined ditches (BMP 7) are likely adequate for the runoff flows expected. Ditches may be hydro-seeded soon after construction with gravel check dams (BMP 11) provided at about 15 m spacing for 0.3 m high check dams. Culverts may be provided as required for flow continuity with inlets and outlets protected with riprap aprons.
- Runoff flow may be directed and dispersed into existing vegetated areas (BMP 2).

The following ESC controls are suggested for where the road traverses the slope:

- Identified wetland areas identified as requiring protection should be isolated with silt fence (BMP 23) before any work commences.
- The road surface should be graded such that all runoff is directed away from the slope edge to a backslope ditch with surface protection. At

about 50 m intervals, the ditch may discharge into rock-lined “soakaway” sumps (BMP 21) with minimum dimensions of say 3 m by 3 m by 1 m deep. It is considered that the granular nature of the material on the right bank will generally adsorb the runoff flow. Centreline overflow culverts leading from the sumps to the exterior slope may also be provided discharging into a riprap apron to disperse the flow into existing vegetated areas.

- All disturbed areas may be hydro-seeded as soon as possible following construction (BMP 14).

5.9 Rail Siding

5.9.1 Description

The proposed rail siding is located on the upper plateau of the right bank. The topography in this area is generally flat lying with intermittent wetland areas. The erosion potential of this area is considered to be low.

5.9.2 ESC Considerations by Area and by Construction Phase

Table 5-8 provides a summary of the ESC considerations from project initiation through to projection closure for the Septimus Rail Siding and is illustrated on Figure 1 and Figure 8.

Table 5-8 Rail Siding ESC Measures

Construction Phase	Construction Activity	ESC Considerations
Site Preparation	Septimus Rail Siding area is cleared exposing soil to potential mobilization	<ul style="list-style-type: none"> • Surface water may be directed through grass lined ditches (BMP 7) with gravel check dams (BMP 11). Where possible, runoff flow may be directed and dispersed into existing vegetated areas (BMP 2). • Infiltration basins (BMP 21) provide an additional opportunity to manage water quality and dispose of excess surface water. • Where contact water from active surfaces is not managed by downstream BMP's, sufficient sources controls, such as seeded compost blanket with tackifer (BMP 16) or sediment logs (BMP 17), must be provided to control contact water.

Construction Phase	Construction Activity	ESC Considerations
Active Use	<ul style="list-style-type: none"> Septimus Siding is utilized for the receiving and delivering of construction materials to site. 	<ul style="list-style-type: none"> Surface drainage may be managed to minimise sediment movement and dispersed to naturally vegetated areas (BMP 2) or infiltrated (BMP 21) in a manner efficient to active site use. Grass lined ditches (BMP 7) may be used to direct flows. Ditches may be hydro-seeded soon after construction with check dams. Culverts may be provided as required for flow continuity with inlets and outlets protected with riprap aprons.
Reclamation of Septimus Rail Siding	<ul style="list-style-type: none"> Dam construction complete 	<ul style="list-style-type: none"> Exposed surfaces may be vegetated to natural conditions. Sediment ponds and infiltration basins (BMP 21) may be converted to permanent wetlands where appropriate and maintained.
Reclaimed Septimus Rail Siding	<ul style="list-style-type: none"> Vegetation in reclaimed areas is established. 	<ul style="list-style-type: none"> Vegetation and wetlands have been re-established.

6. References

BC Hydro, 2016. Construction Environmental Management Plan for the Site C Clean Energy Project (Revision 2), February 4, 2016.

Caux, P.-Y, D.R.J. Moore, and D. MacDonald, 1997. Ambient water quality guidelines for turbidity, suspended and benthic sediments: technical appendix, prepared for British Columbia Ministry of Environment, Lands and Parks, Water Quality Branch, Environment and Resource Management Division, Victoria, BC.

City of Calgary, 2011. Guidelines for Erosion and Sediment Control, October 2011.

Klohn Crippen Berger Ltd. and SNC-Lavalin Inc., 2014. Site C Clean Energy Project, Implementation Design, Reference Concept Report - RSEM and Excavation Area Water Management, November 2014.

Ministry Environment, Lands and of Parks (MELP), 2001. Guidance for Assessing the Design, Size and Operation of Sedimentation Ponds Used in Mining.

FIGURES

Figure 1: Site Disturbance Overview and Catchment Maps

Figure 2: Schematic of LBE Hydraulic Flow Pathways and ESCs by Construction Phase

Figure 3: Schematic of RSEM Area L3 Hydraulic Flow Pathways and ESCs by Construction Phase

Figure 4: Schematic of RSEM Area L5 Hydraulic Flow Pathways and ESCs by Construction Phase

Figure 5: Schematic of RSEM Area L6 Hydraulic Flow Pathways and ESCs by Construction Phase

Figure 6: Schematic of Area R5a and R5b Hydraulic Flow Pathways and ESCs by Construction Phase

Figure 7: Schematic of Area R6 Hydraulic Flow Pathways and ESCs by Construction Phase

Figure 8: Schematic of Septimus Siding Hydraulic Flow Pathways and ESCs by Construction Phase

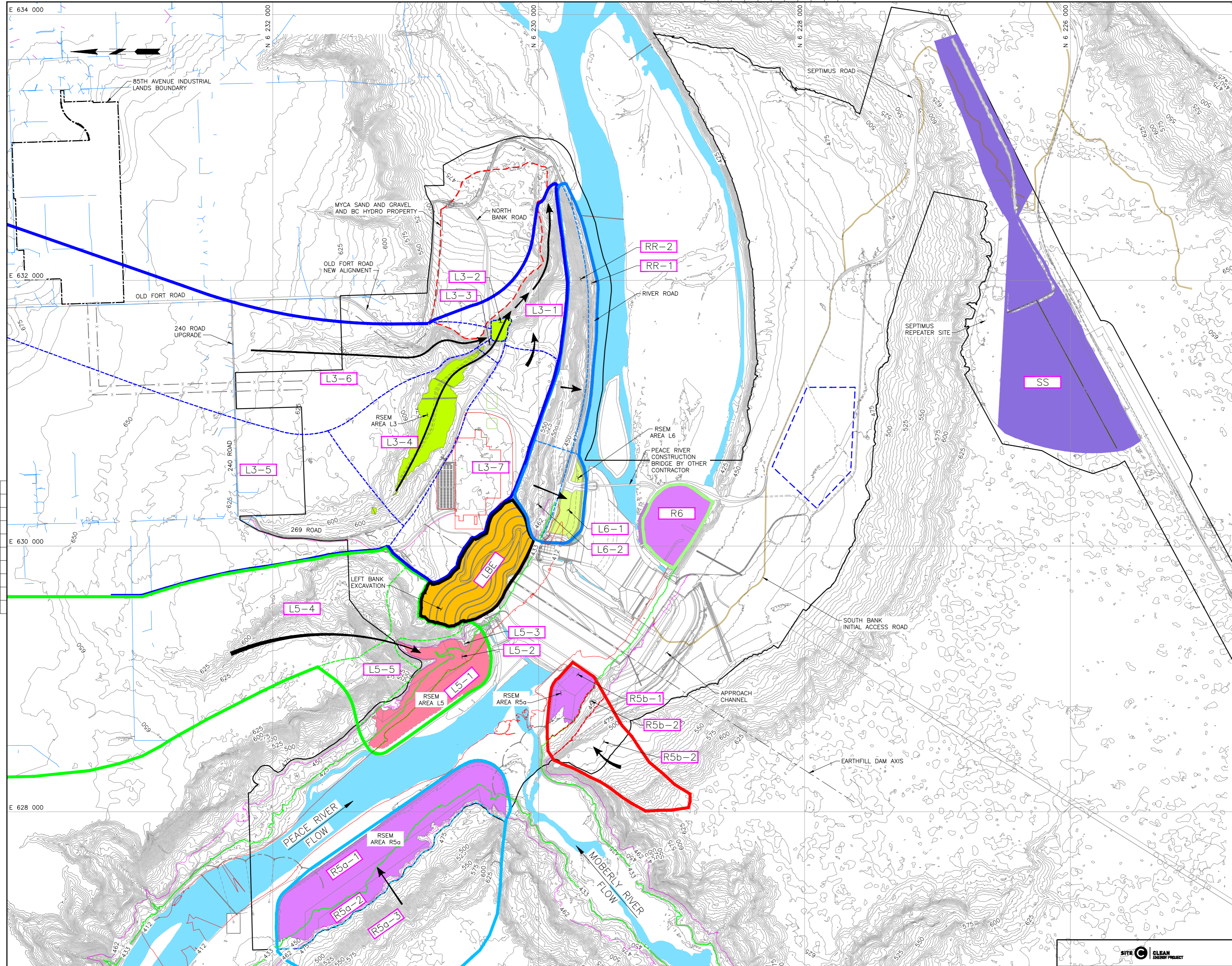

- LEGEND :**
- L5-3 ESC CATCHMENT BOUNDARIES
 - RSEM RELOCATED SURPLUS EXCAVATED MATERIAL
 - ESC AREA RSEM L3
 - ESC AREA RSEM L5
 - ESC AREA L6 + RIVER ROAD
 - ESC AREA RSEM R5a
 - ESC AREA RSEM R5b
 - ESC AREA SEPTIMUS SIDING
 - ESC AREA LEFT BANK EXCAVATION

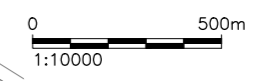

ALL DIMENSIONS ARE IN METRES UNLESS NOTED OTHERWISE



CLEAN ENERGY PROJECT - SITE C
EROSION AND SEDIMENT CONTROL
SITE DISTURBANCE OVERVIEW AND CATCHMENT MAPS
LAYOUT

DSGN	AS A MUTUAL PROTECTION TO OUR CLIENT, THE PUBLIC AND OURSELVES, ALL REPORTS AND DRAWINGS ARE SUBMITTED FOR THE CONFIDENTIAL INFORMATION OF OUR CLIENT FOR A SPECIFIC PROJECT AND AUTHORIZATION FOR USE AND/OR PUBLICATION OF DATA STATEMENTS, CONCLUSIONS OR ABSTRACTS FROM OR REGARDING OUR REPORTS AND DRAWINGS IS RESERVED PENDING OUR WRITTEN APPROVAL.				
INDEP CHK	CIV	STR	MECH	GEO	ELEC
DFTG	DATE				
DFTG CHK	FIGURE NO				
INSP	DWG NO				
REV	1016.2.02.020.ENG00755.PLAN				
ACPT	SK-550				
REPORT NO	SIZE A0				

PLAN
1:10000

L:\21_DRAFTING\04_SKETCHES\SK-550.dwg
 LEE, ANDY
 1/21/2016 3:12 PM

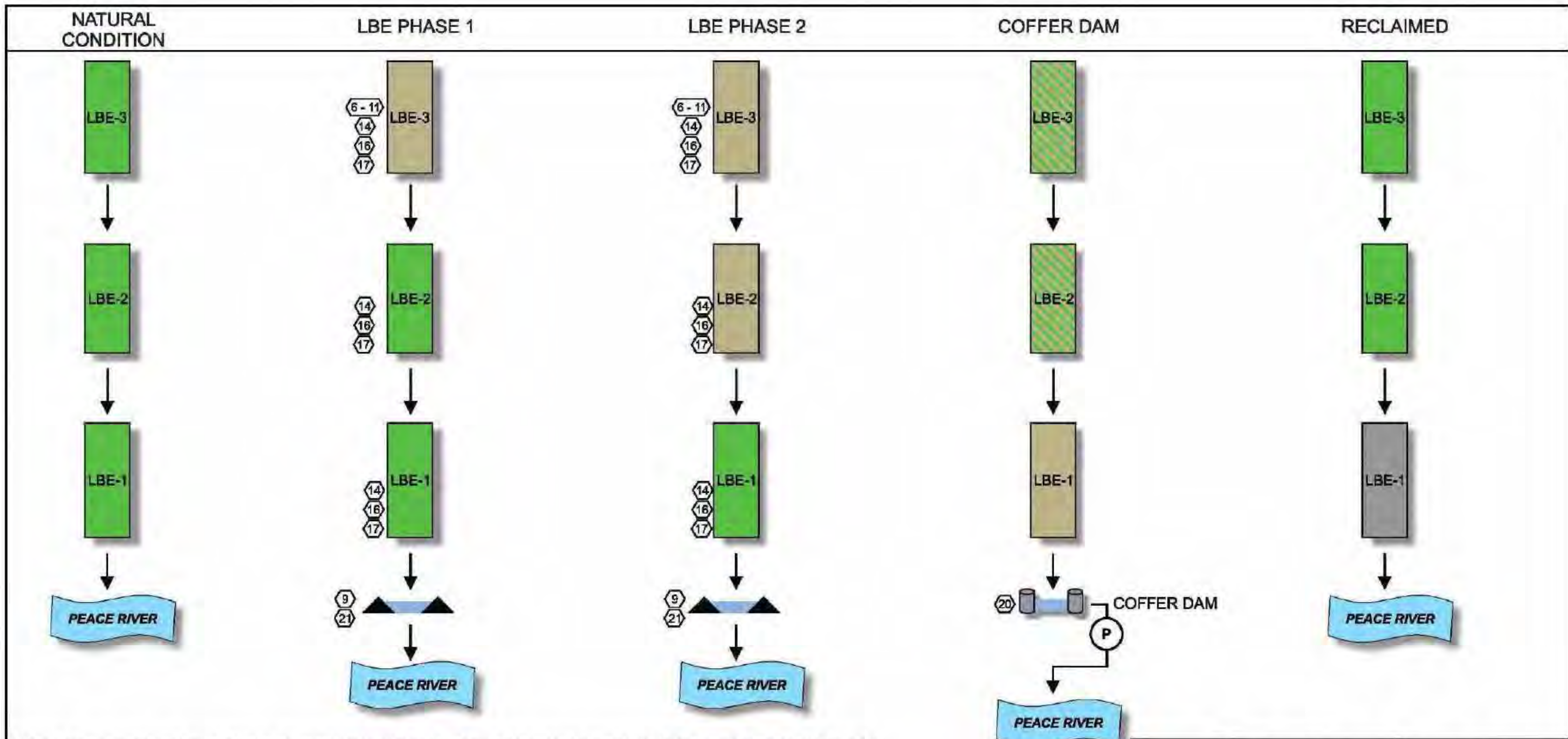

This figure has been prepared to provide general guidance regarding potential erosion and sediment control measures that could be implemented at Site C. Where measures identified on this figure conflict with existing project documentation (construction drawings, technical specifications, CEMP, Reference Concept Report etc), the requirements set out in the existing project documentation shall prevail.

Klohn Crippen Berger SNC-LAVALIN

LEGEND		POND BERM INFILTRATION BASINS CONSTRUCTED WETLANDS		SITE C CLEAN ENERGY PROJECT AS A MUTUAL PROTECTION TO OUR CLIENT, THE PUBLIC AND OURSELVES, ALL REPORTS AND DRAWINGS ARE SUBMITTED FOR THE CONFIDENTIAL INFORMATION OF OUR CLIENT FOR A SPECIFIC PROJECT AND AUTHORIZATION FOR USE AND/OR PUBLICATION OF DATA STATEMENTS CONCLUSIONS OR ABSTRACTS FROM OR REGARDING OUR REPORTS AND DRAWINGS IS RESERVED PENDING OUR WRITTEN APPROVAL. DATE: 19APRIL2016		BC Hydro CLEAN ENERGY PROJECT - SITE C SCHEMATIC OF LBE HYDRAULIC FLOW PATHWAYS AND ESCs BY CONSTRUCTION PHASE FIGURE NO: FIGURE 2	
NATURAL CONDITION	CAPPED & SUBMERGED	DIVERSION	PUMPING	BMP NUMBER	REV	DATE	FIGURE NO
DISTURBED CONDITION	WATER BODY				CIV		FIGURE 2
UNDER REMEDIATION	HARD STRUCTURE				STR		DWG NO
					MECH		SIZE
					EEO		11x17
					ELEC		R

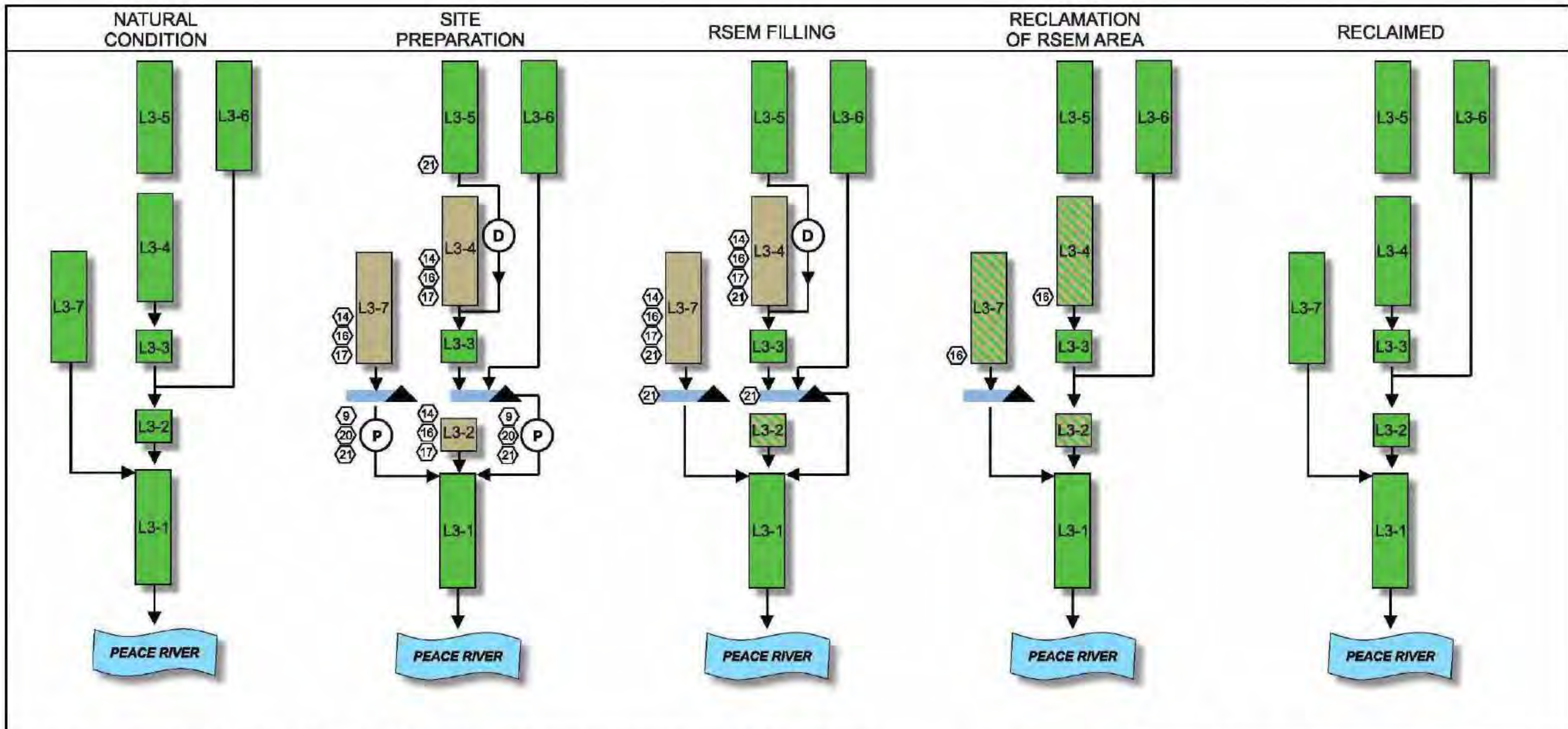

This figure has been prepared to provide general guidance regarding potential erosion and sediment control measures that could be implemented at Site C. Where measures identified on this figure conflict with existing project documentation (construction drawings, technical specifications, CEMP, Reference Concept Report etc), the requirements set out in the existing project documentation shall prevail.

Klohn Crippen Berger SNC-LAVALIN

LEGEND			
	NATURAL CONDITION		CAPPED & SUBMERGED
	DISTURBED CONDITION		WATER BODY
	UNDER REMEDIATION		HARD STRUCTURE
	DIVERSION		PUMPING
	BMP NUMBER		POND
			BERM
			INFILTRATION BASINS
			CONSTRUCTED WETLANDS

SITE C CLEAN ENERGY PROJECT	
DESIGN	
INDEPENDENT CHECK	
DESIGN CHECK	
CONSTRUCTION CHECK	
INSPECTION	
REV	
ACPT	
REPORT NO.	

BC Hydro	
CLEAN ENERGY PROJECT - SITE C	
SCHEMATIC OF RSEM AREA L3 HYDRAULIC FLOW PATHWAYS AND ESCs BY CONSTRUCTION PHASE	
FIGURE NO.	FIGURE 3
DWG NO.	
SIZE	11x17

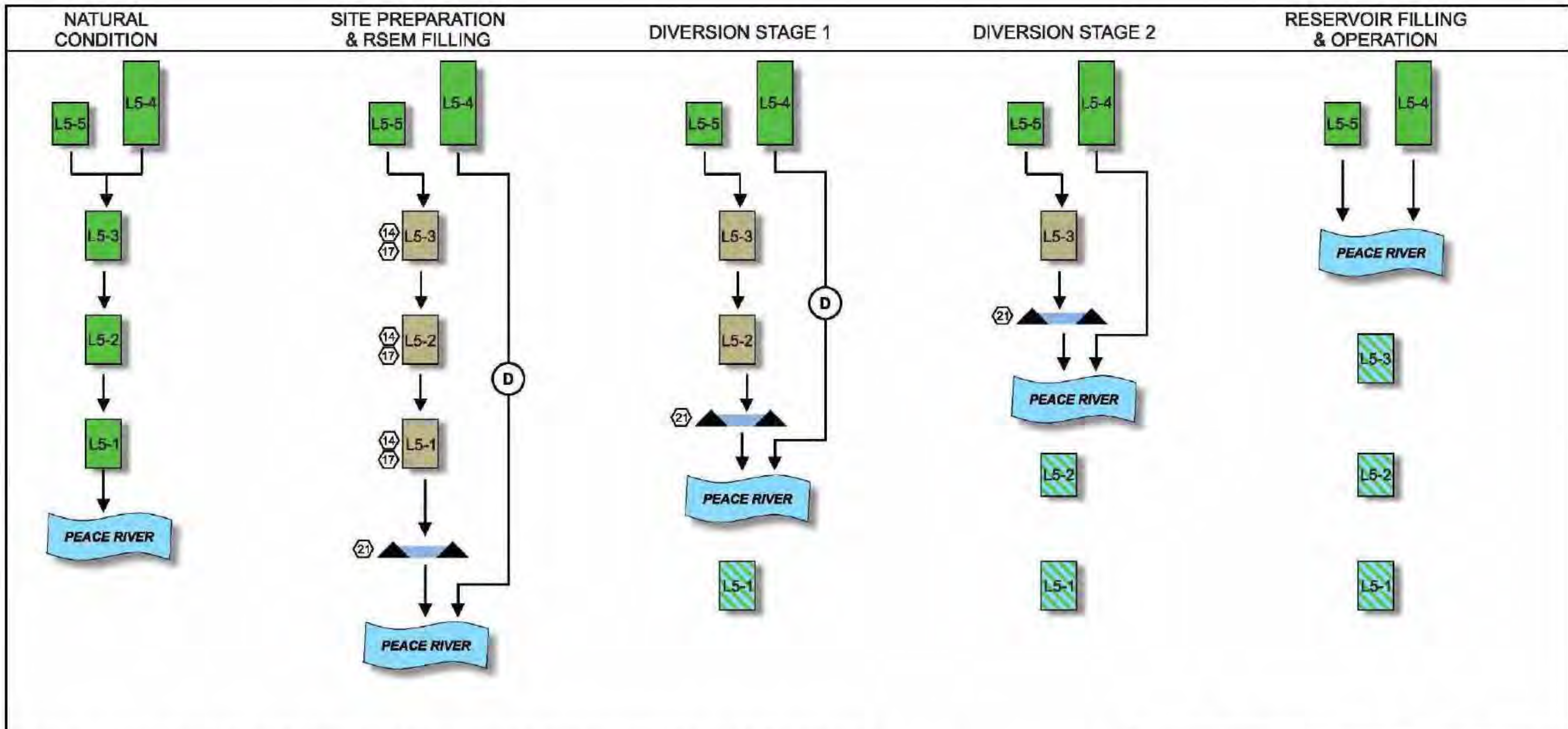

This figure has been prepared to provide general guidance regarding potential erosion and sediment control measures that could be implemented at Site C. Where measures identified on this figure conflict with existing project documentation (construction drawings, technical specifications, CEMP, Reference Concept Report etc), the requirements set out in the existing project documentation shall prevail.

LEGEND

- NATURAL CONDITION
- DISTURBED CONDITION
- UNDER REMEDIATION
- CAPPED & SUBMERGED
- WATER BODY
- HARD STRUCTURE
- DIVERSION
- PUMPING
- BMP NUMBER
- POND
- BERM
- INFILTRATION BASINS
- CONSTRUCTED WETLANDS

SITE C CLEAN ENERGY PROJECT

BC Hydro

DESIGN		AS A MUTUAL PROTECTION TO OUR CLIENT, THE PUBLIC AND OURSELVES, ALL REPORTS AND DRAWINGS ARE SUBMITTED FOR THE CONFIDENTIAL INFORMATION OF OUR CLIENT FOR A SPECIFIC PROJECT AND AUTHORIZATION FOR USE AND/OR PUBLICATION OF DATA, STATEMENTS, CONCLUSIONS OR ABSTRACTS FROM OR REGARDING OUR REPORTS AND DRAWINGS IS RESERVED PENDING OUR WRITTEN APPROVAL.
INDEPENDENT CHECK		
DATE CHECK		
INSPECT		
REV		
ACPT		DATE 19APRIL2016
REPORT NO.		DWG NO.

CLEAN ENERGY PROJECT - SITE C

SCHMATIC OF RSEM AREA L5 HYDRAULIC FLOW PATHWAYS AND ESCs BY CONSTRUCTION PHASE

FIGURE NO. FIGURE 4

SIZE 11x17

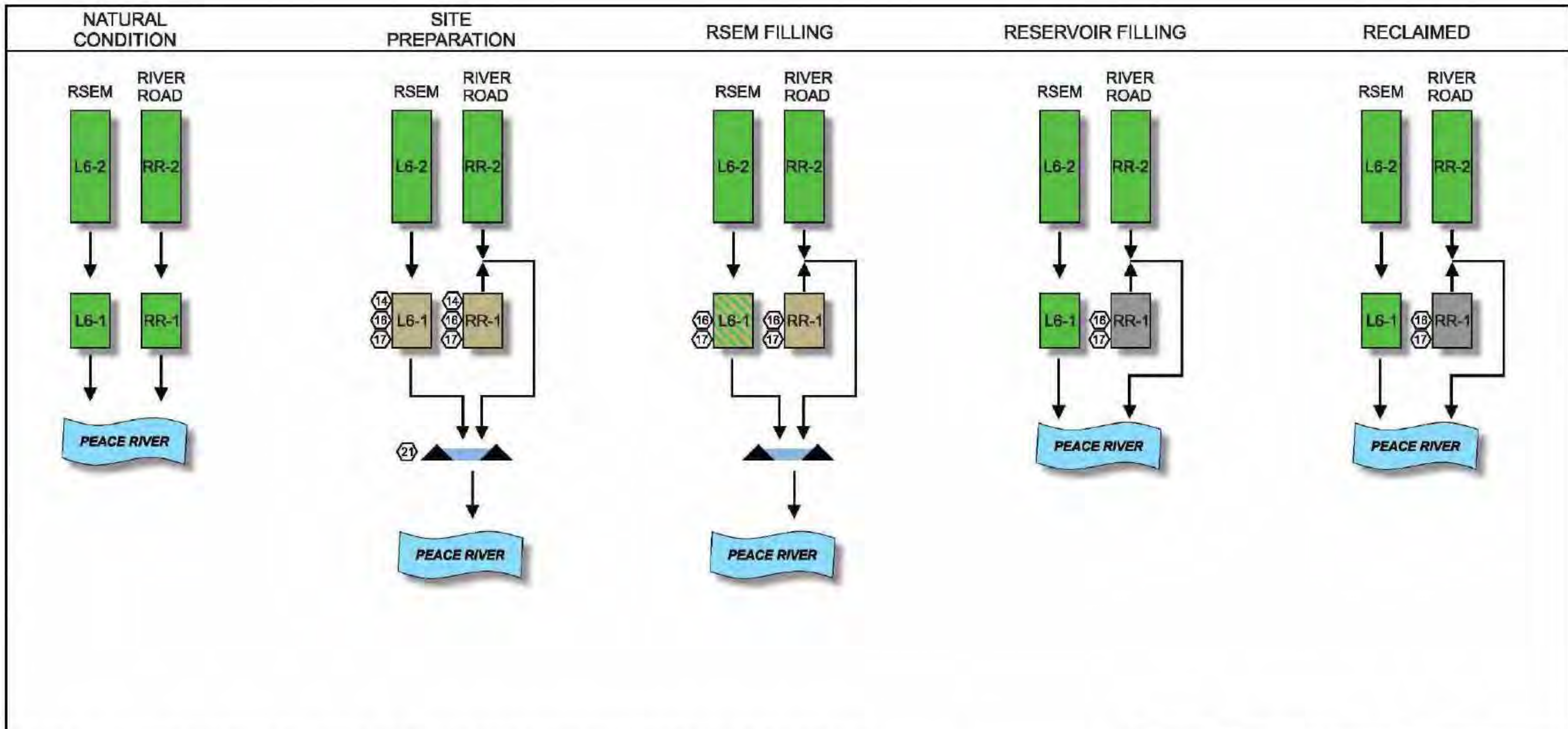

This figure has been prepared to provide general guidance regarding potential erosion and sediment control measures that could be implemented at Site C. Where measures identified on this figure conflict with existing project documentation (construction drawings, technical specifications, CEMP, Reference Concept Report etc), the requirements set out in the existing project documentation shall prevail.

LEGEND		
	NATURAL CONDITION	
	DISTURBED CONDITION	
	UNDER REMEDIATION	
	DIVERSION	
	BMP NUMBER	

CLEAN ENERGY PROJECT - SITE C	
SCHEMATIC OF RSEM AREA L6 HYDRAULIC FLOW PATHWAYS AND ESCs BY CONSTRUCTION PHASE	
DESG INDEP CHK DTG DTG CHK INSP DIV STR MECH GEO ELEC REV ACPT REPORT NO	AS A MUTUAL PROTECTION TO OUR CLIENT, THE PUBLIC AND OURSELVES, ALL REPORTS AND DRAWINGS ARE SUBMITTED FOR THE CONFIDENTIAL INFORMATION OF OUR CLIENT FOR A SPECIFIC PROJECT AND AUTHORIZATION FOR USE AND/OR PUBLICATION OF DATA, STATEMENTS, CONCLUSIONS OR ABSTRACTS FROM OR REGARDING OUR REPORTS AND DRAWINGS IS RESERVED PENDING OUR WRITTEN APPROVAL. DATE 19APRIL2016 FIGURE NO FIGURE 5 DWG NO
SIZE 11x17	

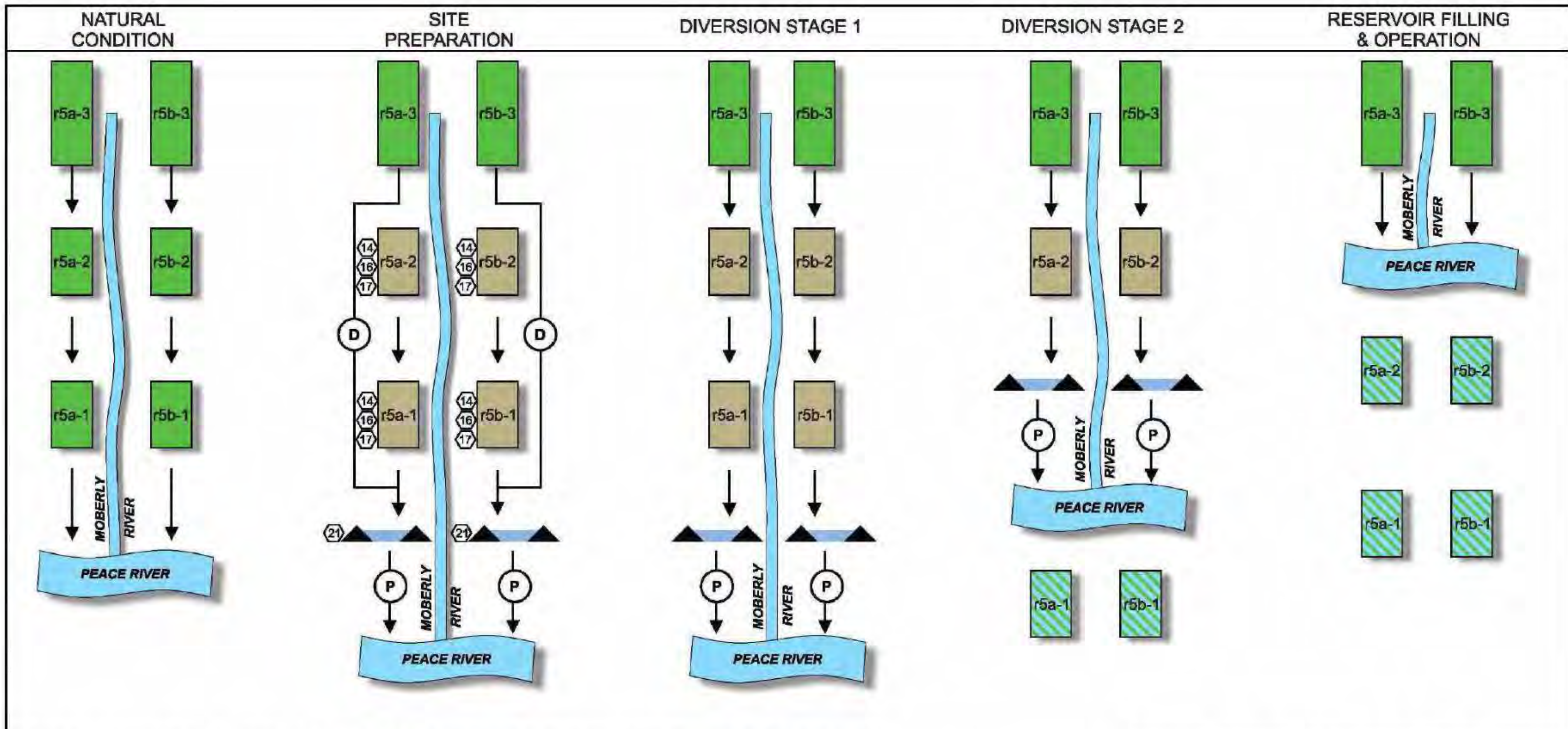

This figure has been prepared to provide general guidance regarding potential erosion and sediment control measures that could be implemented at Site C. Where measures identified on this figure conflict with existing project documentation (construction drawings, technical specifications, CEMP, Reference Concept Report etc), the requirements set out in the existing project documentation shall prevail.

Klohn Crippen Berger SNC-LAVALIN

LEGEND			
	NATURAL CONDITION		CAPPED & SUBMERGED
	DISTURBED CONDITION		WATER BODY
	UNDER REMEDIATION		HARD STRUCTURE
	DIVERSION		PUMPING
	BMP NUMBER		POND
			BERM
			INFILTRATION BASINS
			CONSTRUCTED WETLANDS

SITE C CLEAN ENERGY PROJECT	
DESIGN	
INDEPENDENT CHECK	
DESIGN CHECK	
INSPECTION	
REV	
ACPT	
REPORT NO.	

BC Hydro	
CLEAN ENERGY PROJECT - SITE C	
SCHEMATIC OF RSEM AREA r5a AND r5b HYDRAULIC FLOW PATHWAYS AND ESCs BY CONSTRUCTION PHASE	
DATE	19APRIL2016
FIGURE NO.	FIGURE 6
DWG NO.	
SIZE	11x17

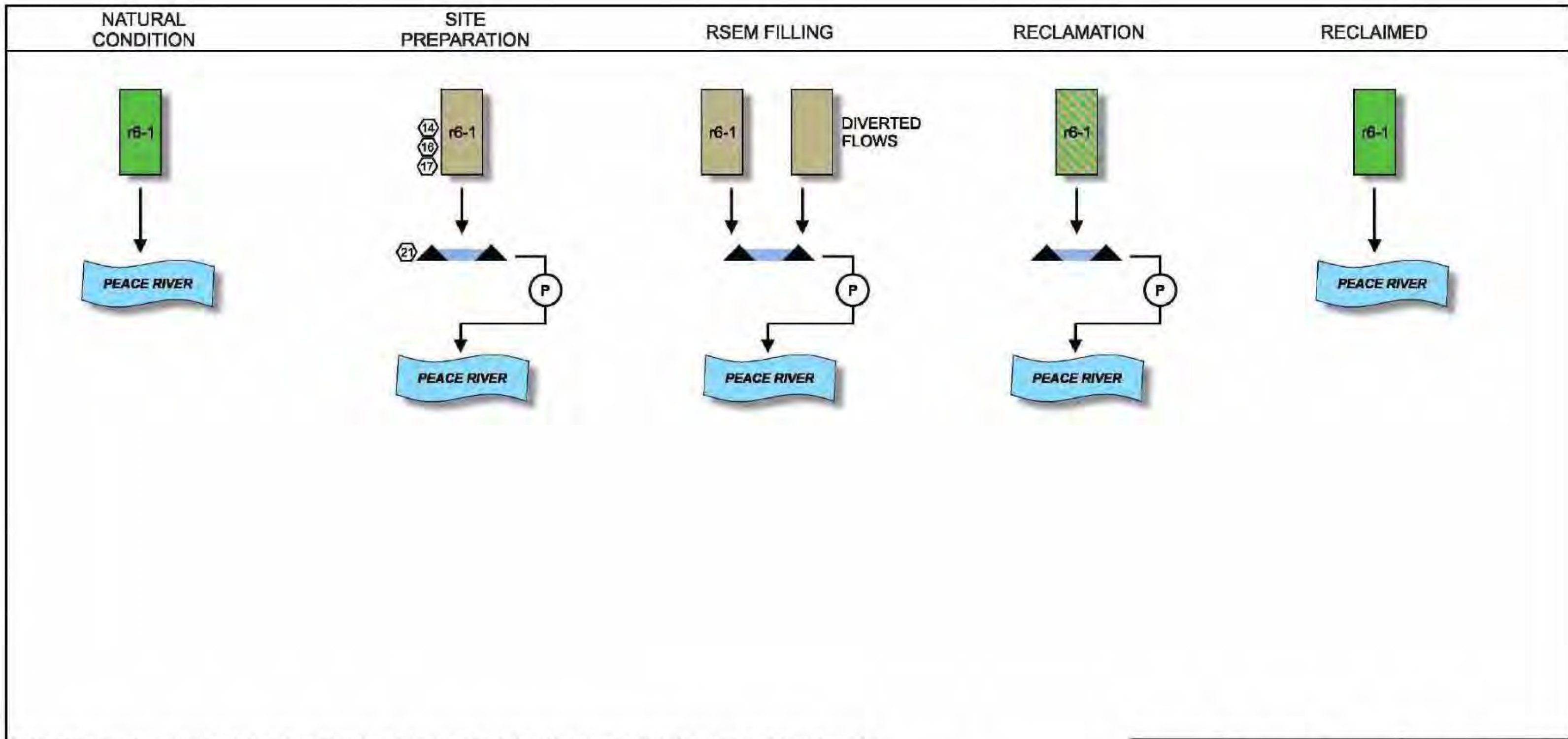

This figure has been prepared to provide general guidance regarding potential erosion and sediment control measures that could be implemented at Site C. Where measures identified on this figure conflict with existing project documentation (construction drawings, technical specifications, CEMP, Reference Concept Report etc), the requirements set out in the existing project documentation shall prevail.

LEGEND		POND BERM INFILTRATION BASINS CONSTRUCTED WETLANDS		SITE C CLEAN ENERGY PROJECT AS A MUTUAL PROTECTION TO OUR CLIENT, THE PUBLIC AND OURSELVES, ALL REPORTS AND DRAWINGS ARE SUBMITTED FOR THE CONFIDENTIAL INFORMATION OF OUR CLIENT FOR A SPECIFIC PROJECT AND AUTHORIZATION OF USE AND/OR PUBLICATION OF DATA STATEMENTS, CONCLUSIONS OR ABSTRACTS FROM OR REGARDING OUR REPORTS AND DRAWINGS IS RESERVED PENDING OUR WRITTEN APPROVAL. DATE: 19APRIL2016		BC Hydro CLEAN ENERGY PROJECT - SITE C SCHEMATIC OF RSEM AREA R6 HYDRAULIC FLOW PATHWAYS AND ESCs BY CONSTRUCTION PHASE FIGURE NO: FIGURE 7	
NATURAL CONDITION	CAPPED & SUBMERGED	DIVERSION	WATER BODY	PUMPING			
DISTURBED CONDITION	WATER BODY	BMP NUMBER	HARD STRUCTURE				
UNDER REMEDIATION							SIZE: 11x17

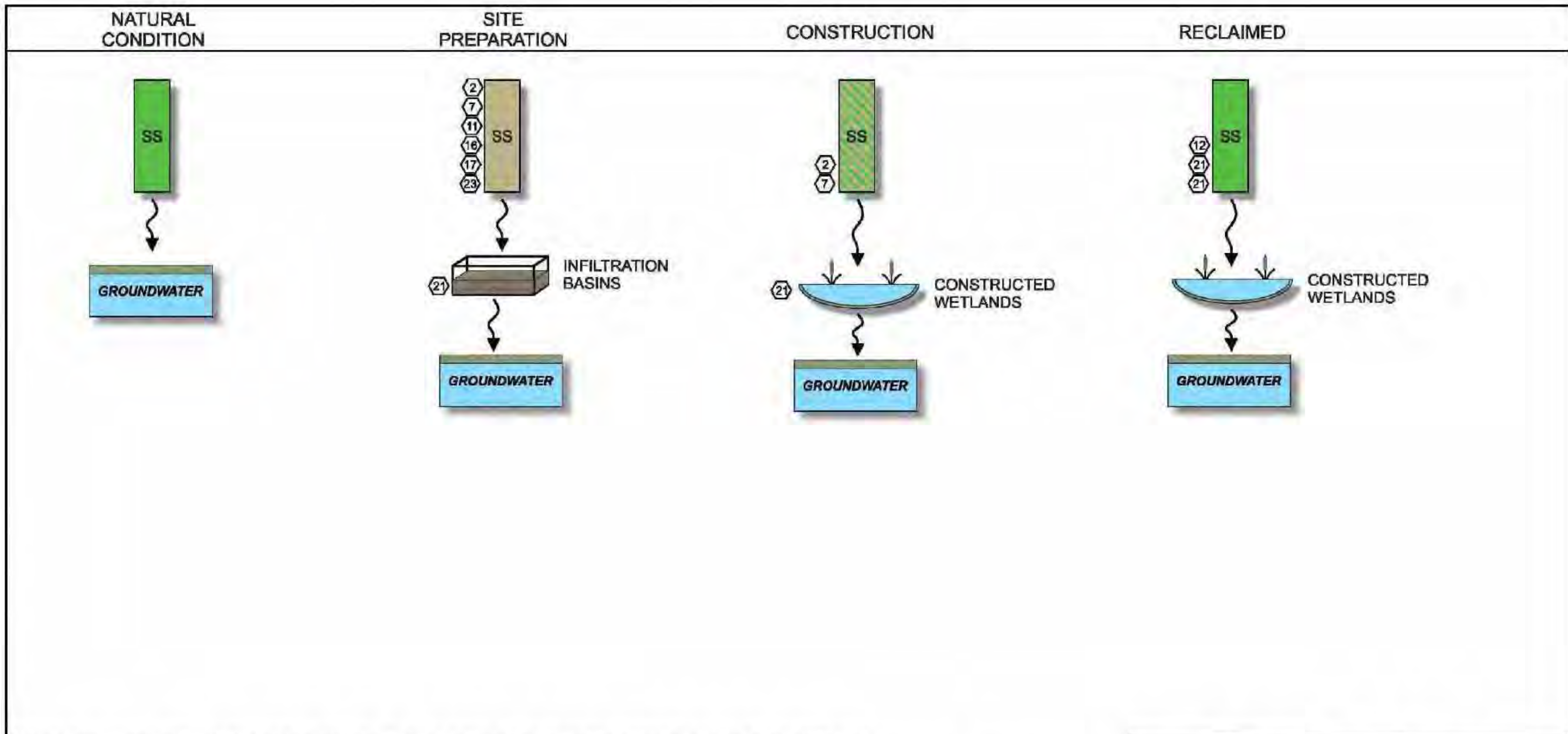

This figure has been prepared to provide general guidance regarding potential erosion and sediment control measures that could be implemented at Site C. Where measures identified on this figure conflict with existing project documentation (construction drawings, technical specifications, CEMP, Reference Concept Report etc), the requirements set out in the existing project documentation shall prevail.

LEGEND

- NATURAL CONDITION
- DISTURBED CONDITION
- UNDER REMEDIATION
- CAPPED & SUBMERGED
- WATER BODY
- HARD STRUCTURE
- DIVERSION
- PUMPING
- BMP NUMBER
- POND
- BERM
- INFILTRATION BASINS
- CONSTRUCTED WETLANDS

SITE C CLEAN ENERGY PROJECT	
DESIGN	AS A MUTUAL PROTECTION TO OUR CLIENT, THE PUBLIC AND OURSELVES, ALL REPORTS AND DRAWINGS ARE SUBMITTED FOR THE CONFIDENTIAL INFORMATION OF OUR CLIENT FOR A SPECIFIC PROJECT AND AUTHORIZATION FOR USE AND/OR PUBLICATION OF DATA STATEMENTS CONCLUSIONS OR ABSTRACTS FROM OR REGARDING OUR REPORTS AND DRAWINGS IS RESERVED PENDING OUR WRITTEN APPROVAL.
INDEP. CHK	
DTG	
DTG CHK	
INSP	
REV	DATE: 19APRIL2016
ACPT	
REPORT NO.	DWG NO.

BC Hydro	
CLEAN ENERGY PROJECT - SITE C	
SCHEMATIC OF SEPTIMUS SIDING HYDRAULIC FLOW PATHWAYS AND ESCs BY CONSTRUCTION PHASE	
FIGURE NO.	FIGURE 8
SIZE	11x17

Appendix A ESC Best Management Practices

BMP 1	CONSTRUCTION SCHEDULING & PHASING	Stripping, Grading and Site Preparation
--------------	--	--

When to Use

Well-planned construction phasing and scheduling can significantly reduce the amount and duration of soil exposed to erosion by wind, rainfall, run-off, and vehicle tracking.

A construction schedule is a written plan of procedure that best identifies major construction and soil disturbing activities, with an approximate time allotted to each schedule item necessary for its completion. The schedule should be sequenced into an orderly listing of all major land-disturbing activities together with the erosion and sediment control practices planned for each activity. The construction schedule should that:

- **Clearing & grubbing**
- **Stripping & grading**
- **Excavation & underground work**
- **Slopes**
- **Borrow/stockpiling**
- **Site haul roads**
- **Protect site perimeter**
- **Protect adjacent areas**

- All major construction/land disturbing activities and associated erosion and sediment control/stormwater management practices are identified
- Contractors are aware of all practices to be implemented prior to and/or during each stage of construction
- Scheduling and phasing reduces both the area of disturbed soils and the length of time disturbed soils are exposed to wind, rainfall, run-off and vehicle tracking (this includes considering the effect the time of year/season has on erosion potential)
- The project complies with erosion and sediment control regulations, commitments and objectives, and that all contractors are aware of compliance requirements and responsibilities
- The schedule is frequently reviewed throughout construction and modified, as required, to meet ESC objectives

Applications and Advantages

- Improves the effectiveness of erosion and sediment control through proper selection and timely implementation of practices during construction
- Allows timely and effective sourcing, procurement and delivery of products and equipment to the site
- Avoids or reduces the need to reactively respond to erosion or sedimentation problems. Having to deal with problems on a reactive basis can result in enforcement actions and the incorrect selection and installation of controls (due to an absence of materials on-site and a lack of time to properly select and install control measures).
- Although construction scheduling/phasing may increase stripping and grading time and costs due to reduced economy of scale, effective scheduling/phasing can significantly reduce the requirement for erosion and sediment control practices (reduced time and costs for planning, implementing, inspecting and maintaining practices)

Limitations

- Scheduling and phasing requires frequent re-assessment and modification (note: scheduling and sequencing is likely to change as projects proceed, so updates will need to be made to the site erosion and sediment control documents)

- Mitigation of risk and liability not only depends on well-planned scheduling and sequencing: it ultimately depends on proper implementation, inspection and maintenance of erosion and sediment control practices
- Sites requiring a lot of excavation and balancing of soil needs can be difficult to phase at stripping and grading stage

Implementation

- A construction schedule and sequence, including identification of ESC measures, should be developed.
- The construction schedule and sequence should comply with applicable regulations, commitments and contractual obligations
- The construction schedule and sequence should be frequently reviewed and modified (when required) to meet changing or unexpected site conditions
- Minimize the area of disturbed, exposed soil at each project stage by:
 1. Breaking the project site into project phases or smaller work areas
 2. Clearly identifying and implementing construction site boundaries (with signage and fencing/barriers) that confine construction activities within defined areas
 3. Controlling construction vehicles to minimize tracking
 4. Protecting and retaining existing vegetation, whenever possible (include vegetated buffer/filter strips at the site perimeter and to protect water bodies; develop and implement a tree and shrub protection plan that identifies all trees/shrubs and other vegetation to be protected)

Note: Whenever feasible, incorporate staged topsoiling and revegetation of graded slopes as work progresses. Do not leave topsoiling and revegetation until the end of the project

- Minimize the time that disturbed soil is exposed to erosion and vehicle tracking by:
 1. Completing all work, including the establishment of vegetation cover/permanent erosion control, in one phase before moving to the next phase
 2. Avoiding highly erodible soils or minimizing the time such soils are exposed (stabilize immediately)
 3. Integrating erosion and sediment control implementation into construction activities
 4. Avoiding, where possible, construction activity during wet weather and wet site conditions
- Use stabilized conveyance channels to divert clean run-on and run-off away from exposed areas
- Regularly inspect and maintain all controls and practices
- Plan for and practice erosion and sediment control year round. Unexpected rainfall and snowmelt can cause significant erosion at any time of the year. Stabilize all exposed soils, control run-on and run-off and always maintain wet-season sediment trapping devices

Inspection and Maintenance

Routinely verify construction activities and erosion and sediment control implementation is in accordance with the schedule and take corrective action when required. Document site inspections and retain a copy on site

BMP 2	PRESERVE EXISTING VEGETATION	Stripping, Grading and Site Preparation
--------------	-------------------------------------	--

When to Use

Dense vegetation cover protects soil from raindrop impact and can typically reduce erosion rates by 98% compared to sites stripped of vegetation and topsoil. Existing native vegetation usually provides the best soil protection. Only disturbing areas immediately needed for construction is one of the best ways of reducing sediment yield.

The use of buffer strips around water bodies and construction site perimeters provides filtering of sediment from surface run-off. Where possible, it is recommended to protect riparian (adjacent to water bodies) vegetation and habitat during the planning and implementation of construction projects.

- **Clearing & grubbing**
- **Stripping & grading**
- **Slopes**
- **Buffer strip around sensitive areas and site perimeter**

Note: The cost for preserving existing vegetation during construction will likely be less than the cost of applying erosion and sediment control practices to the disturbed area. Replacing vegetation damaged or destroyed during construction can be expensive.

Applications and Advantages

- Protecting existing dense vegetation is far more effective than other erosion and sediment control practices
- Incorporate existing native vegetation into the final landscape plan. Native vegetation is adapted to the site, drought tolerant, and will provide shade and erosion protection
- Where possible, existing trees should be protected
- Buffer strips around the perimeter of a site can reduce or eliminate off-site sedimentation
- Protect all areas where natural vegetation exists that are designated for environmental reserve. Such areas often include steep slopes, watercourses and riparian habitat

Limitations

- For sites with diverse topography, it is often difficult and expensive to save existing vegetation while grading the site satisfactory for the planned development

Implementation

- Areas of existing vegetation that are scheduled for preservation should be clearly marked with a temporary fence. Minimize disturbance by locating temporary roadways, storage facilities, and parking areas away from preserved vegetation.
- Notify all employees, surveyors, and subcontractors of vegetated areas to be protected.
- Keep equipment away from trees to prevent root and trunk damage. Trenching should be as far away from tree trunks as possible, typically outside the drip line. Trenches should be filled in as soon as possible to avoid root drying. Fill trenches carefully and tamp the soil to fill in air pockets. If roots are exposed to the air, cover them with soil or wet burlap as soon as possible.
- Consider the impact of grade changes to existing vegetation and the root zone.
- Aerate soil that has been compacted over a trees root zone with a mechanical aerator.
- Fertilize stressed or damaged broadleaf trees to aid recovery. Fertilize trees in the late fall or early spring.
- To avoid damage during site cleanup and stabilization, retain protective measures until all construction activity is complete.

Inspection and Maintenance

Follow inspection and maintenance timing requirements and inspect all areas of the construction sites where vegetation is to be preserved. Immediately repair any damage and ensure immediate follow-up with the parties responsible for causing damage.

Erosion and Sediment Control Report/Drawings Requirements

If a report is required, indicate vegetated areas that are to be preserved, including environmentally sensitive areas and buffer strips. On the drawings showing existing and intermediate site conditions, clearly delineate areas where vegetation is to be preserved and provide details on any fencing or other boundaries required on site.



Use of a vegetated buffer strip in combination with a perimeter silt fence and a topsoiled and tracked slope. BMPs work most effectively if they are implemented as part of a system of erosion & sediment control.

BMP 3	SURFACE GRADING, ROUGHENING & SLOPE TEXTURING	Stripping, Grading and Site Preparation
--------------	--	--

Description and Purpose

Note: The practices outlined in this BMP are not stand-alone measures; they should be used in conjunction with other erosion and sediment control practices.

Texturing exposed slopes and stripped/graded areas by roughening the soil surface or installing tracks, grooves, furrows or benches that conform to contours helps interrupt the movement of sheet run-off across exposed areas, reducing effective slope lengths and decreasing potential for sheet and rill erosion. Roughening of exposed soils and tracking/grooving/furrowing perpendicular to the prevailing wind can

also significantly reduce the detachment and creep/saltation of soil particles by wind.

- **Stripping & grading to Final Stabilization**
- **Slopes**
- **Stockpiles**

Applications and Advantages

- These measures are suitable for all compacted stripped/graded areas and all disturbed areas, especially slopes 3H:1V or steeper (on fresh cut of fill slopes to a maximum gradient of 2H:1V)
- Surface roughening and slope texturing are temporary erosion control measures that need to be used in conjunction with erosion control BMPs. Surface roughening provides some instant erosion protection for exposed soils prior to final stabilization with vegetation or other cover
- Texturing will create pockets to entrap coarse sediment, reducing the sediment yield down-slope.
- Good suitability for freshly cut or filled slopes (at least 8 m in length) with a maximum slope of 2H:1V, with reasonably cohesive soils
- Benching/terracing can be used to reduce the effective length of long slopes (break up slopes)
- Decreasing run-off velocity and surface wind speed decreases erosion potential
- Increases infiltration of run-off into the soil
- Traps and retains seed detached by water and/or wind
- Provides beneficial 'seedling-safe' sites for germination/establishment of seedlings
- Enhances the performance of topsoiling, mulching and hydroseeding

Limitations

- Generally impractical for short slopes with insufficient room for machinery to maneuver
- Generally not suitable for excessively steep slopes and/or non-cohesive soils
- May cause water build-up and sloughing in wet/seepage areas (obtain geotechnical advice)
- These practices provide limited, short-term benefit and work best when used as part of a system of practices/controls
- Grading costs may be increased

Installation

- Do not run heavy equipment on excessively wet soils as this will increase compaction

Surface Roughening/Furrowing

- Always leave exposed soils in a rough-graded condition; do not smooth grade soil
- On large, relatively flat stripped and graded areas, reduce wind erosion potential by furrowing or ripping the soil perpendicular to the prevailing wind direction (using the ripper teeth on a grader is very effective; depth should be 0.15 to 0.30 m). When furrowing sloped areas, ensure that the furrows run perpendicular to the fall of the slope

Surface Tracking (also known as cat-tracking or track-walking)

- Use tracked construction equipment to move up and down the slope, leaving depressions perpendicular to the slope direction. Limit machine-tracking to one or two passes to prevent excessive compaction
- Avoid this practice on excessively wet or clayey soils
- Tracked depressions in the soil will decrease run-off velocities, trap sediment, improve seedling development and increase infiltration of water
- For topsoiling and surface tracking, be sure to immediately seed and mulch roughened areas to obtain optimum seed germination and seedling growth. Establish good soil and seed contact

Terracing/Benching

- Construct narrow, flatter sections of terrain on the slope, perpendicular to slope direction
- Benches/terraces should be reviewed by a qualified geotechnical engineer for slope stability
- Benches/terraces should be graded back towards the slope and drain with a gentle gradient to a stable outlet
- This practice should be carefully considered as benching increases local slope gradients and, where positive down-slope gradients and drainage is not provided for all areas, can result in ponding, gully formation and slope instability

Inspection and Maintenance

- Inspect a minimum of once every seven (7) days and during or within 24 hours of rapid snowmelt, rainfall events of 12 mm or greater in a 24 hour period, or rainfall on saturated soils
- Areas damaged by rilling or erosion should be re-graded and re-seeded

Construction Details

Refer to the following figures:

Surface Roughening

Stepped or Terraced Slopes

Grooved or Serrated Slopes

Erosion and Sediment Control Report/Drawings Requirements

- If a report is required, describe locations that will require surface roughening/furrowing, surface tracking and/or terracing, and outline the various stages of construction where these practices are to be implemented. On the drawings, clearly delineate areas to receive this treatment and provide construction details, including notes on timing, inspection and maintenance



TRACKING

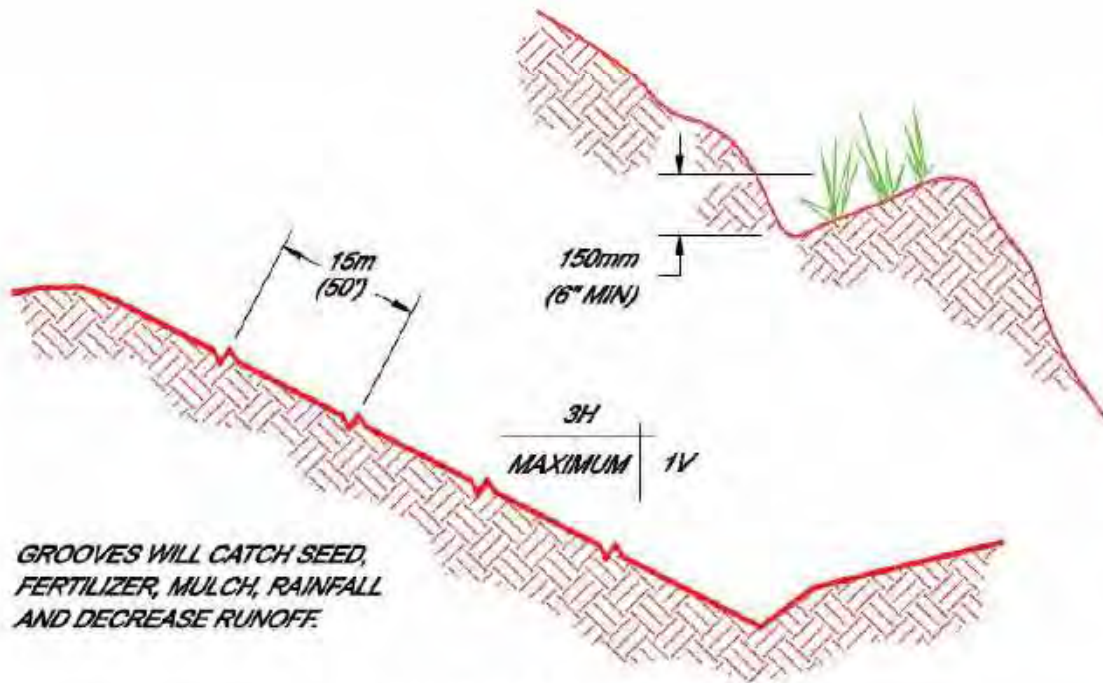

CONTOUR FURROWS

Surface Roughening



Erosion & Sediment Control Guidelines 2011

Source: Salix Applied Earthcare - Erosion Draw 5.0
 © 1994 JOHN McCULLAH FILE: srfrough.dgn

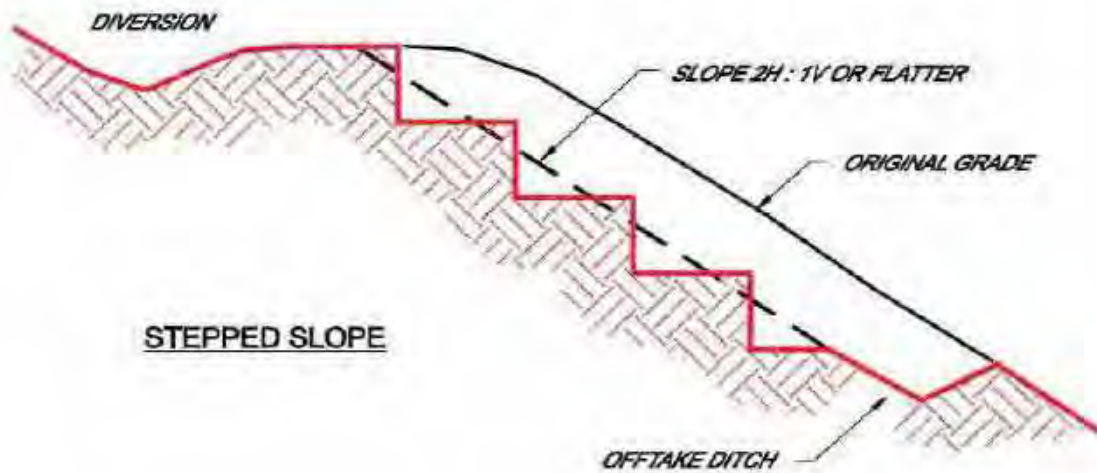

STEPPED SLOPE

NOT TO SCALE

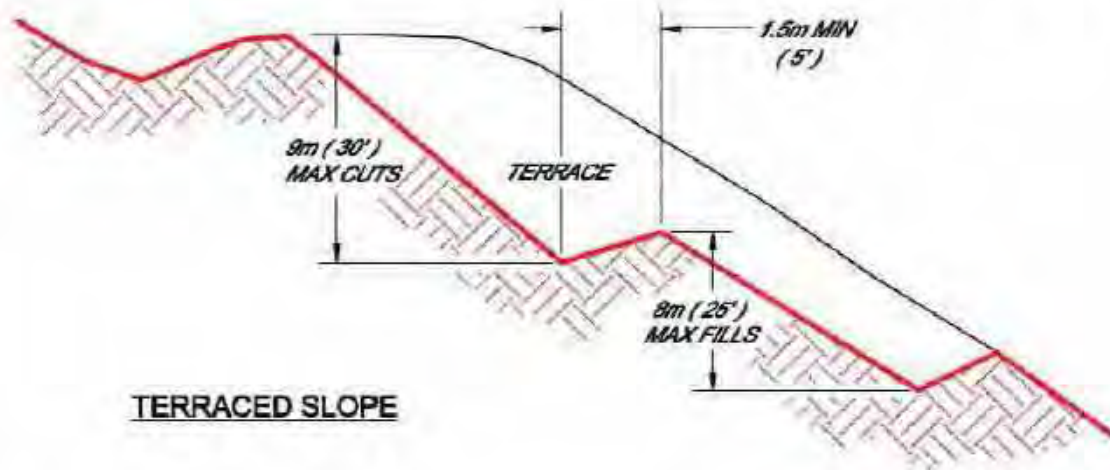

TERRACED SLOPE

NOTES:

1. VERTICAL CUT DISTANCE SHALL BE LESS THAN HORIZONTAL DISTANCE.
2. VERTICAL CUT SHALL NOT EXCEED 0.6m (2') IN SOFT MATERIAL AND 0.9m (3') IN ROCKY MATERIAL.

Stepped or Terraced Slope



Erosion & Sediment Control Guidelines 2011

Source: Salix Applied Earthcare - Erosion Draw 5.0
© 1994 JOHN McCULLAH FILE: stpslope.dgn

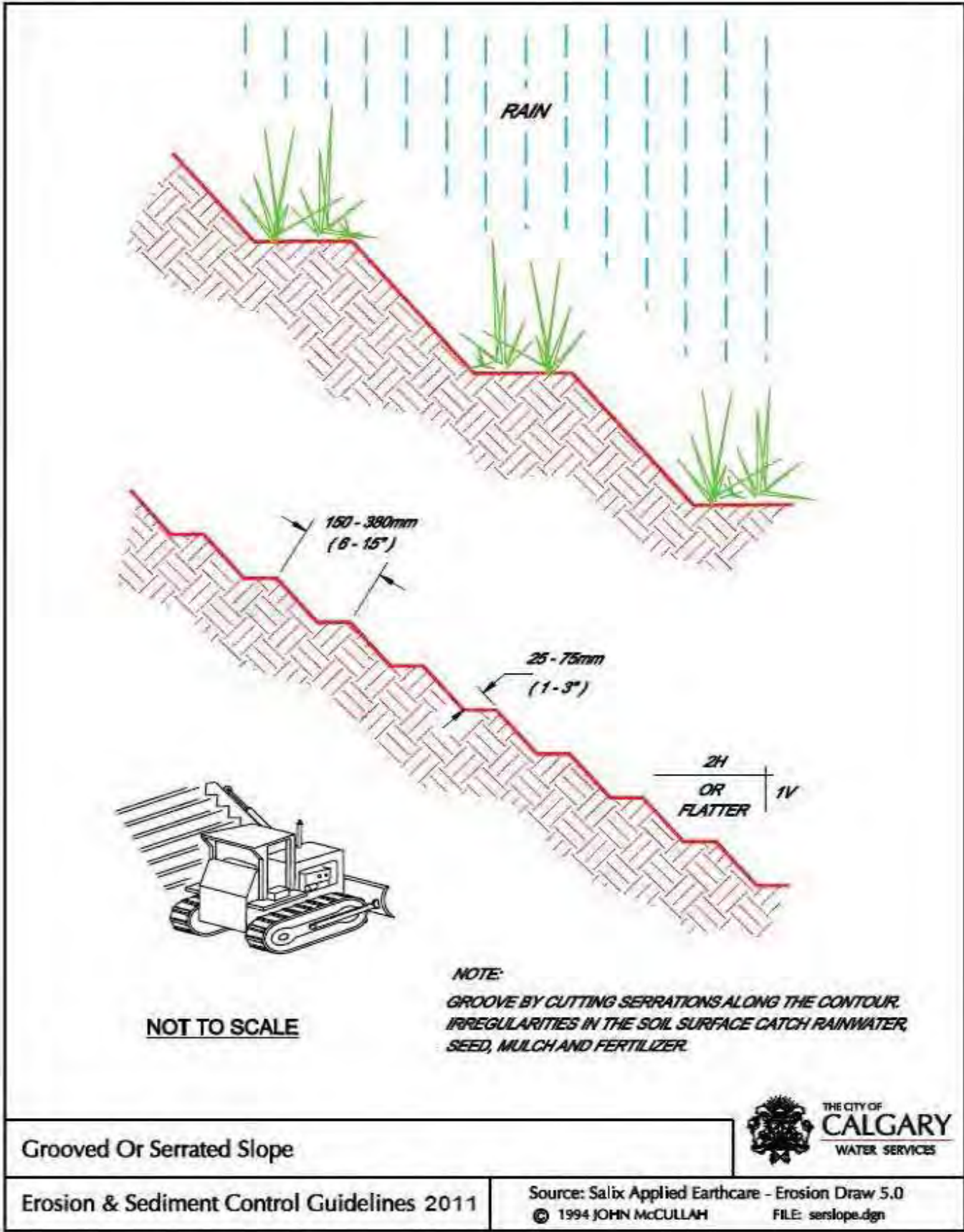

BMP modified from the City of Calgary - Guidelines for Erosion & Sediment Control (2011 Edition) Appendix A Best Practices For Controlling Erosion and Sedimentation on Urban Construction Sites

BMP 4	TOPSOIL SALVAGE AND PLACEMENT	Stripping, Grading and Site Preparation
--------------	--------------------------------------	--

Description and Purpose

The preservation and use of topsoil enhances final stabilization of construction sites with vegetation. Topsoil is the surface horizon (A horizon) of the soil profile, generally characterized as being darker than subsoil due to the presence of organic matter. The A horizon constitutes the major zone of root development and microbial activity, providing much of the nutrients and water available to plants.

- **Clearing & grubbing**
- **Stripping & grading**
- **Slopes**
- **Borrow Areas**
- **Haul Roads**
- **All Sizes of Sites**

Topsoil is defined as “a fertile, friable, natural loam, containing not less than 4% organic matter for clay loams and not less than 2% organic matter for sandy loams to a maximum of 15%. Topsoil should be free of rocks >50mm in diameter, subsoil contamination, roots and weeds and have a pH within 7.0 – 8.5. Native soils should be used for restoration of natural areas and environmental reserves (by stripping and stockpiling the A horizon)”.

The **timely** placement of topsoil (which typically has a coarser texture and better structure than subsoil) over mineral soil can significantly reduce raindrop and sheet erosion potential and increase infiltration.

Topsoiling may involve bringing in soils from off-site or merely replacing fertile topsoil that was stripped and stockpiled during earlier site development activities. The salvage and placement of topsoil can provide a suitable growth medium for the establishment of sustainable vegetation cover and a supply of native or locally occurring seeds/propagules.

Applications and Advantages

- A sufficient supply of topsoil is required (salvaged and/or suitable imported material).
- Topsoil application is recommended on slopes 2H:1V or flatter.
- This practice is especially useful where it is desirable to establish native plants and indigenous grasses from seeds “banked” in the topsoil.
- Topsoil is usually placed prior to seeding, mulching and installation of rolled erosion control products (RECPs) or planting of trees/shrubs.
- Topsoil stockpiles can help shield the construction site from the neighbouring developments and help to reduce the amount of dust and noise coming from the site.
- Placing topsoil provides enriched an organic medium and nutrients for plant development.
- Topsoil absorbs raindrop energy and promotes infiltration (reduced erosion potential).

For construction sites, salvaging or importing suitable topsoil is required where the subsoil or existing soil has:

- Texture, pH, or nutrient balance that cannot be modified by reasonable means to provide an adequate growth medium;
- Material that is too unsuited to provide an adequate root zone and to supply necessary moisture and nutrients for plant growth, and/or;
- Substances potentially toxic to plant growth.

Limitations

- Successful topsoil stripping on large sites requires soil survey information showing topsoil locations and depth.
- Topsoil should not be applied to frozen or saturated subsoil.
- Topsoil is generally not appropriate for slopes steeper than 2H:1V, unless additional erosion controls (such as rolled erosion control products) are installed.
- Storage stockpiles of topsoil should be carefully located to avoid double handling.

Implementation (stockpiling and placement)

Note: The following notes are provided for guidance only. Always consult a professional specializing in erosion & sediment control to ensure appropriate planning, implementation, inspection and maintenance of erosion & sediment controls and practices.

- Do not apply topsoil that has significantly contrasting texture to the subsoil (for example: placement of sandy topsoil over clayey subsoil can cause lateral movement of water between soil layers and resulting slumping).
- Working the topsoil into the subsoil layer to a depth of at least 150 mm can improve bonding and water infiltration.
- All surface run-off control structures should be in place prior to soil stripping.
- Care should be taken to avoid contamination with undesirable subsoil when stripping/salvaging topsoil.
- Topsoil should be friable and loamy (loam, sandy loam, silt loam, sandy clay loam, clay loam). It should be free of debris, garbage, stumps, rocks, roots, and noxious weeds, and should be able to support healthy plant growth.

Topsoil Stockpiling

- First, determine if the quality and quantity of topsoil available will justify selective handling and will be suitable for reapplication (loam, sandy loam and silt loam topsoil is ideal; sandy clay loams, silty clay loams, clay loams and loamy sands are reasonable; heavy clay topsoil and organic peats and mucks are not suitable).
- Use soil survey/geotechnical information to determine the depth of topsoil stripping (it is likely to be variable across the site).
- Implement sediment basins/traps, diversions, and other temporary controls before stripping.
- Only strip topsoil from areas to be disturbed by excavation, road building or compaction.
- Topsoil stockpiles should be located in flat areas, away from overland drainage.
- Topsoil stockpiles should be located so as not to interfere with construction activities.

- A number of strategically placed small stockpiles allow for more economical, easier replacement during final site stabilization.
- All subsoil and topsoil stockpiles in place for more than seven days should be protected with temporary erosion control such as mulch/tackifier or covered. Stockpiles that will be in place more than thirty days should be vegetated.

Topsoil Placement

- Prepare the ground surface to final grade by removing large rocks and debris.
- Loosen the subgrade by discing or scarifying to a depth of at least 75mm (or to 200mm where subsoil compaction exceeds 95% standard proctor).
- Topsoil should be uniformly distributed to a depth of at least 150mm for seeded areas to 600mm for shrub planting.
- Apply topsoil with a dozer or light track equipment to the design thickness.
- Topsoil should be applied in a moist condition and kept moist to reduce wind erosion.
- Do not apply topsoil in a frozen or muddy condition, when the subgrade is excessively wet, or when conditions exist that may be detrimental to proper grading or proposed sodding or seeding.
- Machine track walk upslope or down slope (do not over compact topsoil by heavy equipment; only track walk with one pass) to provide contour tracking (erosion control practice).
- If seeding or sodding over topsoil, work should be completed as soon as possible following topsoil placement.
- Until vegetation is established the topsoil should be regularly moistened during prolonged dry weather to reduce wind erosion and promote germination and seedling establishment (application of tackifier/mulch may be required to provide temporary erosion control).

Inspection and Maintenance

Prior to final stabilization, inspect areas that have received topsoil application at least once per week and after significant storm events (sufficient to cause erosive run-off) and snowmelt.

Areas damaged by washouts or rilling should be re-graded, re-topsoiled and seeded immediately.



Photo 9: Providing vegetation cover on this soil stockpile controls erosion and helps preserve the biological, chemical and physical integrity of the soil. Perimeter control (silt fence) was installed around the pile to control migration of sediment during stabilization.



Photo 10: Timely final grading and site preparation, followed by application of topsoil reduces the exposure of highly erodible subsoil to erosion. Upon completion of topsoil application, additional erosion control measures detailed in the Erosion & Sediment Control Plan should be implemented.

BMP 5	STABILIZED CONSTRUCTION ENTRANCE/EXIT	Stripping, Grading and Site Preparation
--------------	--	--

Definition and Purpose

Note: Gravel or rock can be prone to tracking off-site, especially where large vehicles are leaving the site. Coarse woody slash material offers a good alternative to gravel where rock is being tracked onto adjacent streets.

Site access/exit points should be stabilized so as to reduce the tracking/flowing of sediment off construction sites by vehicles. Stabilization traditionally consists of application of a geotextile/gravel. Placement of a layer of coarse woody slash (such as chipped woody material from construction site clearing) also provides an excellent option for controlling track-out. There are also manufactured portable products available for temporary construction entrance and exit control. When used in combination with regular inspection and cleaning of adjacent streets (as necessary), this practice reduces the off-site deposit of sediment onto public roads and into storm sewer catch basins.

- **Clearing & grubbing**
- **Stripping & grading**
- **Haul Roads**
- **Borrow Areas**
- **All Sizes of Site**

Tracking pads should be installed at all locations where vehicles enter or exit a construction site. In addition, it may be necessary to include a wash station with a water supply and wash water containment & detention for excessively muddy vehicles.

Note: Construction plans must limit traffic to properly constructed and stabilized entrances/exits. Construction exit sediment control is limited by the effort to control sediment at the source: Where possible, keep traffic off wet or clayey soils. Conduct frequent inspections for mud-tracking and implement a street cleaning program if tracking of mud continues to be a problem.

Limitations

- May be limited by space constraints.
- Tracking pads require frequent inspection and maintenance (such as top-dressing), especially during wet conditions or tracking of clayey soils.
- Gravel/rock should be placed on geotextile to prevent 'punching' of material into the ground and reduced effectiveness.
- A properly constructed wash station may be required for washing of excessively muddy vehicles along with regular inspection and cleaning of adjacent public streets.

Implementation

- Optimal rock size for gravel pads is 50–75 mm (ensure rock is hard, durable and angular). Erosion control drawings should indicate the specific grade and dimensions of the rock to be applied.
- The thickness of the pad should not be less than 150 mm. The width and length of the pad should be as required, but a minimum width of 3.6 m (12 feet) and a minimum length of 13 m (50 feet).

- Locate construction entrances and exits to limit sediment leaving the site and to provide for maximum ease of use by all construction vehicles. Avoid entrances which have steep grades and entrances to curves in public roads.
- The entrance should be maintained in a condition that will prevent tracking or flowing of sediment onto public rights-of-way. This may require periodic top dressing with additional rock and repair/maintenance of any measures used to trap sediment.
- All sediment spilled, dropped, washed or tracked onto local streets should be removed immediately.
- When necessary, vehicle wheels/tires should be washed to remove sediment prior to entrance onto local streets. When washing is required, it should be done on an area stabilized with crushed stone that drains into an approved sediment trap.

Inspection and Maintenance

- Maintain the gravel pad in a condition to prevent mud or sediment from leaving the construction site (frequently inspect and top-dress with clean rock as required).
- After each rainfall, inspect any structure used to trap sediment and clean it out as necessary.
- Immediately remove all objectionable material spilled, washed or tracked onto public roads.

Construction Details

Refer to figure:

Temporary Gravel Construction Entrance/Exit



SECTION A-A

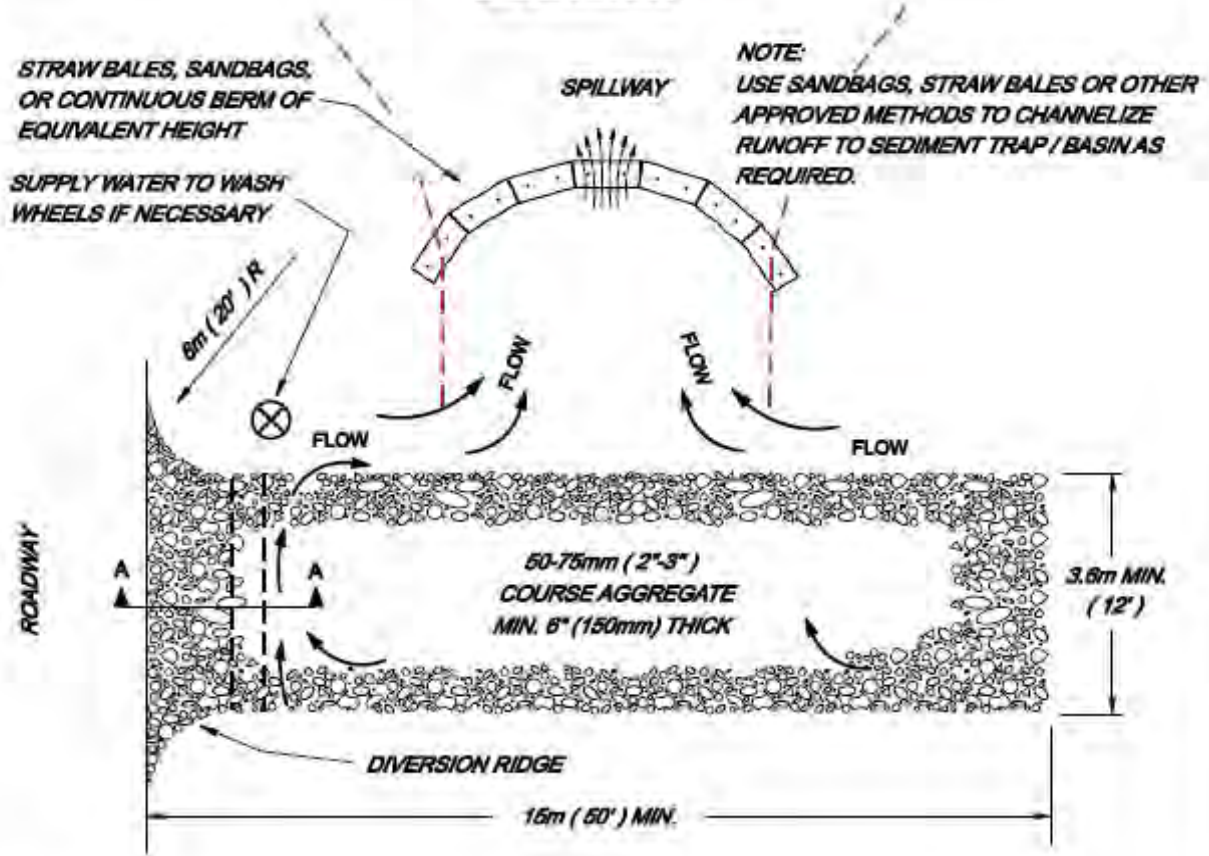

PLAN

NOTES:

1. THE ENTRANCE SHALL BE MAINTAINED IN A CONDITION THAT WILL PREVENT TRACKING OR FLOWING OF SEDIMENT ONTO PUBLIC RIGHT-OF-WAYS. THIS MAY REQUIRE TOP DRESSING, REPAIR AND/OR CLEAN OUT OF ANY MEASURES USED TO TRAP SEDIMENT.
2. WHEN NECESSARY, WHEELS SHALL BE CLEANED PRIOR TO ENTRANCE ONTO PUBLIC RIGHT-OF-WAY.
3. WHEN WASHING IS REQUIRED, IT SHALL BE DONE ON AN AREA STABILIZED WITH CRUSHED STONE THAT DRAINS INTO AN APPROVED SEDIMENT TRAP OR SEDIMENT BASIN.

Temporary Gravel Construction Entrance / Exit



Erosion & Sediment Control Guidelines 2011

Source: Salix Applied Earthcare - Erosion Draw 5.0
 © 1994 JOHN McCULLAH FILE: entrance.dgn

BMP 6	TEMPORARY BERMS AND CHANNELS FOR RUN-OFF DIVERSION OR STORAGE	Erosion Control: Stormwater Conveyance
--------------	--	---

Description and Purpose

Temporary Diversion Berm: A temporary ridge of compacted soil constructed to divert or pond run-off (from catchment areas ≤ 2 ha / 5 acres) away from sensitive areas such as exposed slopes or water bodies. Note: Where the berm serves to divert run-off, flows should be contained in a stabilized channel (swale or ditch) to a stabilized outlet. Temporary diversion dikes are often used as a perimeter control in association with a sediment trap or basin. If properly installed in the first phase of grading, construction and maintenance costs are very low.

- **Stripping & grading to Final Stabilization**
- **Haul Roads**
- **Stormwater Conveyance**
- **Slopes**

Continuous Berm (also see BMP 22 Compost Berms and Compost Filter Socks): A temporary diversion berm or sediment barrier constructed with soil, sand or aggregate encased within geosynthetic fabric. Continuous berms may be used to intercept and divert sheet flow from smaller contributing areas (< 0.4 ha or 1 acre), allowing sediment to settle. Continuous berms are an excellent alternative to silt fence as they provide continuous contact with the ground surface and do not require entrenchment. Continuous berms are useful for erosion & sediment control around the perimeter of a construction site. Continuous berms may be constructed as filter berms (with aggregate and permeable filter fabric) to facilitate the trapping of sediment and the drainage of stormwater.

Temporary Diversion Channel: Where a temporary berm is intended to divert run-off around sensitive areas or to a sediment-trapping facility, it will be necessary to construct a ditch or swale to convey run-off to a stabilized outlet.

Applications and Advantages

- Used as a temporary measure. Properly designed earthen berms and diversion channels may also be used as a permanent measure.
- Commonly located along the crest of exposed cut and fill slopes, around the site perimeter, as perimeter protection around material stockpiles or around water bodies or other sensitive areas.
- Can also be located below steep grades where run-off begins to concentrate.
- On moderately sloping areas, berms may be placed at intervals to trap and divert sheet flow before it has a chance to concentrate and cause rill and gully erosion.
- To protect adjacent property, buildings and structures from flooding.
- Used in conjunction with slope drains (refer to BMP 9).
- An effective method of intercepting, diverting and conveying surface run-off around or through a construction site to a stabilized outlet channel or sediment-trapping facility in a non-erosive manner.
- Minimizes erosion caused by excessive sheet flow over exposed slopes.
- Flow velocities are kept to a minimum, some settling of solids may

be achieved, and infiltration is permitted. When included in the site landscaping plans, permanent berms and diversion channels can be attractive and functional.

- Open channels are usually less expensive to construct than other types of conveyance.
- Open channels are easy to inspect and maintain.

Limitations

- Diversion channels may have to be lined to prevent erosion.
- Diversion channels should be designed by a geotechnical engineer/hydrologist if flow velocities and/or volumes are large. Berms greater than 1 m in height should be designed by a geotechnical engineer. In addition, in determining the level of design and construction required, the consequences of failure should be considered.
- Channels should be located on stable slopes and should maintain positive drainage to avoid water ponding and breaching of channel flow.
- Accumulated sediment may require regular cleanup and channel maintenance may be difficult due to limited access
- Run-off should be directed to a stabilized outlet and channel.

Implementation

- Care should be applied to correctly size and locate earthen berms, drainage channels and continuous berms. Excessively steep, unlined channels may be subject to erosion and gully formation.
- It is important to stabilize berms and channels with vegetation or other erosion-resistant materials as soon as possible after construction. The contributing drainage area of permanent diversions should also be stabilized as soon as possible to prevent excessive erosion and sediment deposition in the channel.
- When working on public land, always check the suitability of seed mixes and vegetation with relevant authorities.

Temporary or Permanent Diversion Berm

- Temporary diversion berms should be installed as a first step in stripping and grading activities and should be functional prior to land disturbance in the upstream catchment area.
- Berms should be constructed of suitable material and adequately compacted to prevent failure.
- Berms should be located so as to minimize damages by construction operations and traffic.
- Berms can usually be constructed with equipment used for site grading.
- The catchment area for a temporary berm should not exceed 2 ha.
- Construct the berm from the bottom up by placing and compacting lifts of soil (suitable material and degree of compaction to be determined by the designer).
- Typical berm dimensions are: ≥ 0.5 m high, with a crest of ≥ 0.6 m. Berms should be trapezoidal in cross section with side slopes of 2H:1V or flatter for mixed, cohesive or coarse-grained soils that can be compacted and 3H:1V or flatter for poorly cohesive fine-grained soils.

- To prevent erosion, temporary and permanent diversion or containment berms should be stabilized immediately following construction (i.e. seed and mulch, coarse aggregate cover). Sections of the berm that run-off could flow against will require stabilization with material that can withstand expected water velocity/shear.
- To ensure drainage, berms should include a diversion channel with a positive grade to a stabilized outlet, naturally stabilized channel or sediment trap/basin.

Diversion Channels

- Channels should be constructed with a parabolic or trapezoidal cross sections, with side slopes of 2H:1V or flatter for mixed, cohesive or coarse-grained soils that can be compacted and 3H:1V or flatter for poorly cohesive fine-grained soils. Prior to constructing a diversion channel, construct a stabilized outlet or ensure run-off will flow to a naturally stabilized channel or sediment trap or basin.
- The final channel should have the proper grade and shape of the cross section in order to discharge the design flow and provide positive drainage (minimum 2% slope). Where possible, channel gradient should be minimized so as to minimize erosion.
- Where channel gradient exceeds 2%, armour/stabilize the channel with material designed to withstand water velocity/shear (such as riprap, rolled erosion control blankets, vegetation or a combination of suitable practices).

Continuous Berms

- Continuous berms are generally used as a perimeter control for trapping and filtering sheet run-off from small contributing areas. As with silt fence, the contributing area draining to a berm should not exceed 0.4 ha (1 acre) and contributing slopes should not exceed 10 m in length.
- Continuous berms are constructed with a continuous berm machine (CBM). A CMB has a material feeding chamber (hopper) and fabric rolling system that creates the continuous berm by 'wrapping' geosynthetic material around sand, aggregate or soil.
- When employed to capture or divert run-off at the toe of a slope, the continuous berm should be constructed at least 2 – 3 m from the toe of the slope (to provide adequate storage or diversion to a stabilized outlet).
- Woven geotextile is preferred as a casing material due to higher tensile strength. Local suppliers may be able to provide biodegradable casing material for areas where it is required or desirable.
- Drainage of ponded water is dependent upon fabric flow rates and the infill material. Higher permeability material should be used to permit drainage in low lying areas.
- Removal of the berm can be accomplished by splitting the berm, spreading the fill material and removing the fabric.

Inspection and Maintenance

- Except during freeze-up, berms and channels should be routinely inspected at least once every two weeks.
- Measures should be inspected after significant rainfall or snowmelt likely to cause erosion, with immediate repairs to berms, channels, outlet or sediment traps as necessary.
- Prior to freeze-up, ensure all temporary berms and channels are adequately stabilized to handle snowmelt.
- Berms used to trap sediment should be inspected and cleaned out after every significant storm or as needed during regular maintenance.

- Damages caused by construction traffic or other activity should be repaired before the end of each working day.
- Reseed areas where vegetation does not become established.

Construction Details

Refer to figures:

Temporary Diversion Dike

Continuous Berm

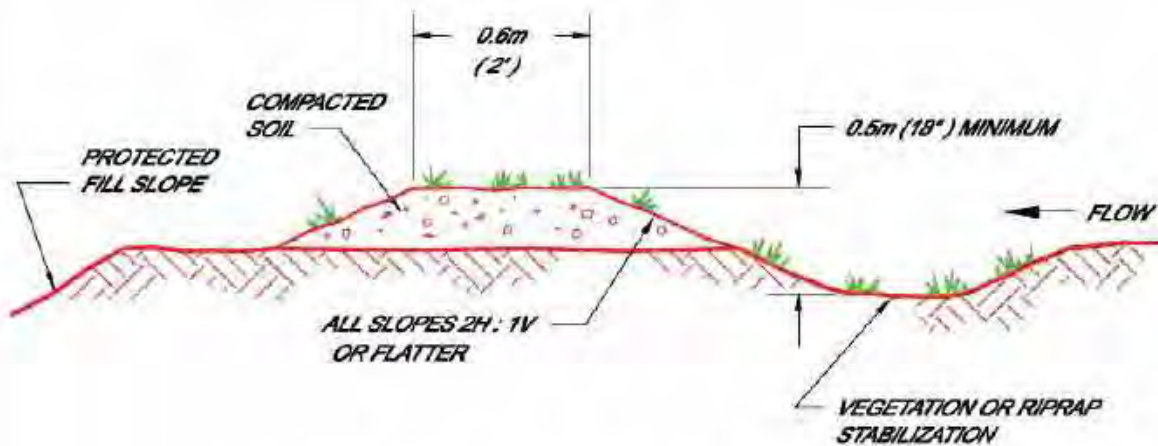

TYPICAL FILL DIVERSION

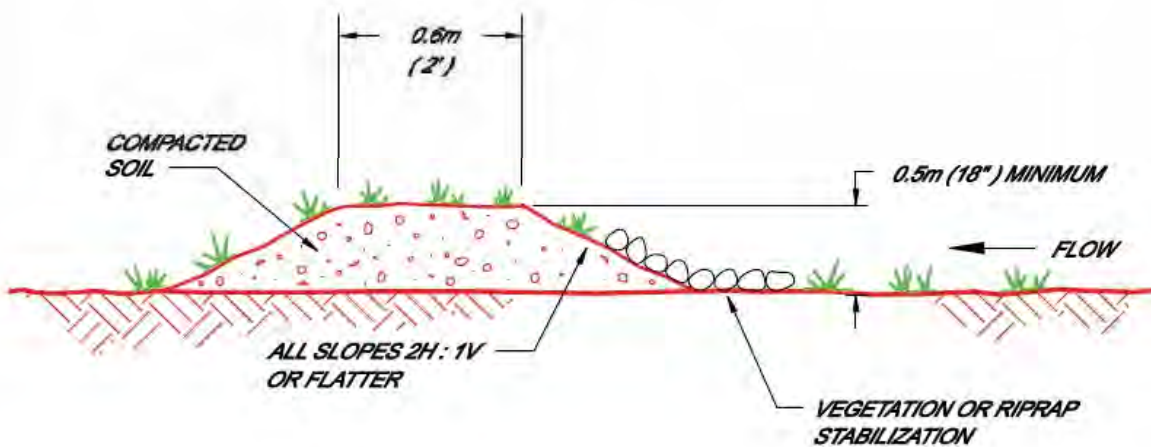

TYPICAL TEMPORARY DIVERSION DIKE

NOTES:

1. THE CHANNEL BEHIND THE DIKE SHALL HAVE POSITIVE GRADE TO A STABILIZED OUTLET.
2. THE DIKE SHALL BE ADEQUATELY COMPACTED TO PREVENT FAILURE.
3. THE DIKE SHALL BE STABILIZED WITH TEMPORARY OR PERMANENT SEEDING OR RIPRAP.

Temporary Diversion Dike



THE CITY OF
CALGARY
WATER SERVICES

Erosion & Sediment Control Guidelines 2011

Source: Salix Applied Earthcare - Erosion Draw 5.0
© 1995 JOHN McCULLAH FILE: tempdike.dgn

TYPICAL APPLICATION

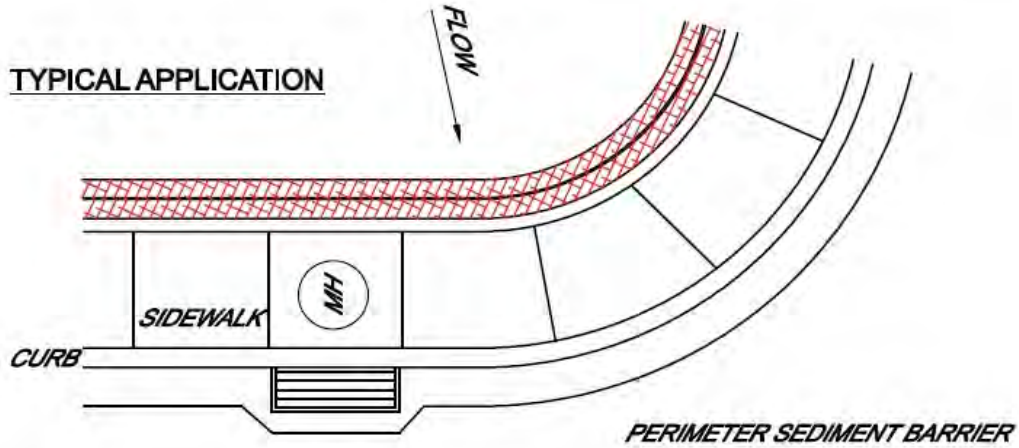

FRONT VIEW

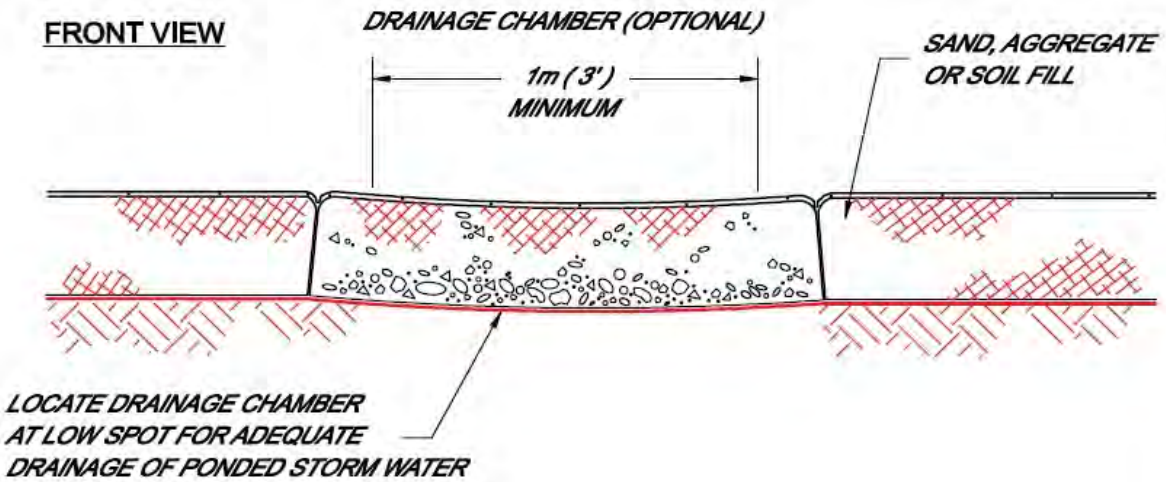

SIDE VIEW

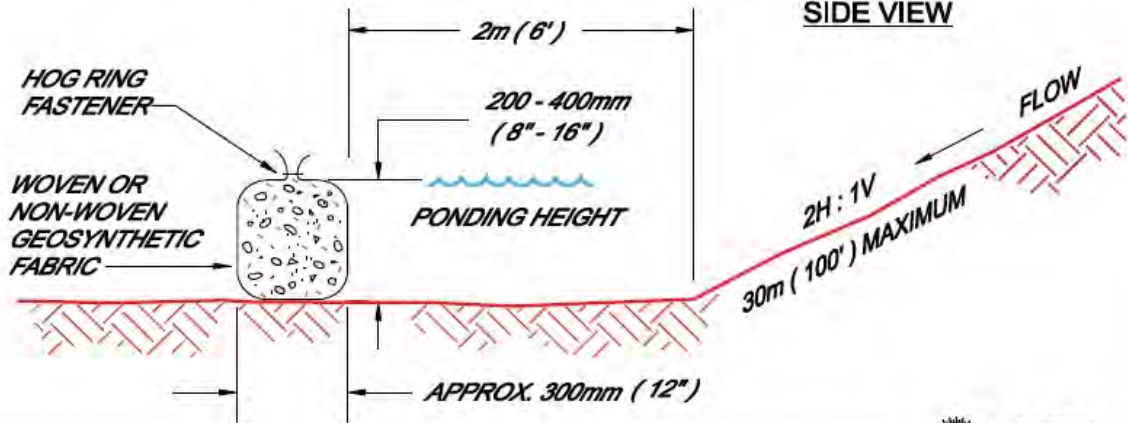

Continuous Berm



Erosion & Sediment Control Guidelines 2011

Source: Salix Applied Earthcare - Erosion Draw 5.0
© 1995 JOHN McCULLAH FILE: contberm.dgn

BMP 7	GRASSED/VEGETATED CHANNELS	Erosion Control: Stormwater Conveyance
--------------	-----------------------------------	---

Description and Purpose

Vegetation can be used to line natural or constructed channels/swales to provide erosion protection. Vegetation in channels reduces erosion by lowering water velocity over the soil surface and by binding soil particles with roots. Vegetation works best in channels subject to periodic flows of relatively low velocity run-off. Grassed linings are most commonly used for channels (native species, including woody species such as willow could also be suitable for some channels).

- **Stormwater Conveyance**
- **Stripping & grading to Final Stabilization**
- **Temporary or Permanent Measure**

Applications and Advantages

- Incorporating vegetation cover into channels is suitable for channels with maximum grade $\leq 5\%$.
- Vegetated channels resemble natural channels and should be the preferred option where low gradients and design velocities are possible.
- Relatively easy to construct.
- Provide reduced flow volume by allowing infiltration and reduce outlet velocities by providing surface roughness.
- Can provide some pre-treatment of run-off (reduce sediment/other pollutants) prior to discharge to another treatment system (i.e. storm ponds).
- Vegetated channels should be constructed at 1 – 5% grade to convey drainage at low velocities.
- In areas with steep slopes, vegetated channels are best suited to locations where they can be placed almost parallel to the contours.
- Ideally, channel cross sections should be wide, with relatively flat side slopes, allowing surface run-off to enter over the vegetated banks without causing erosion. Riprap may be needed to protect the channel banks in sections where flow velocities and/or turbulence could cause erosion.

Cross-section designs include:

- V-shaped Vegetated Ditches: V-shaped ditches are commonly constructed in narrow corridors (i.e. along roadsides) to convey small quantities of water. Where high flows may occur, V-shaped ditches should be avoided as they can result in high velocity flows.
- Parabolic Vegetated Channels: Parabolic channels can handle larger flow velocities, but require more space. Riprap should be considered where higher velocities are expected and where some dissipation of energy (velocity) is desired. A combination of grass lining with riprap or turf reinforcement mat centres is useful when accommodating continuous low flow in the channel.
- Trapezoidal Vegetated Channels: Used where run-off volumes are large and channel gradient is low (so that velocities are non-erosive to vegetated linings). A riprap lined centre can be included to accommodate low flows.

Limitations

- Vegetation establishment in channels can be slow in northern climates. Additional stabilization measures may be required until a vigorous, sustainable vegetation cover is achieved (for example: Rolled Erosion Control Products, Cellular Confinement Systems, Hydromulching/ Hydroseeding).
- Vegetation will not survive in sections of channels subject to sustained flow. Channels in areas with a high water table or seepage may require a subsurface drain, riprap centre or other suitable means to convey base flow (since sustained wetness usually prevents adequate vegetative development).
- Soils should be suitable to establish a vigorous stand of vegetation. If dense vegetation cannot be maintained in the swale, its effectiveness will be severely reduced.
- Channel excavation may produce a significant amount of spoil material.

Implementation

- The channel shape may be parabolic, trapezoidal, or V-shaped, depending on requirements.
- Vegetated channels should be capable of adequately handling a 10 year, 24 hour design storm.
- To aid in vegetation establishment and allow for maintenance, channel side slopes should be 3H:1V or flatter.
- Late spring and summer are good times for construction of a grassed waterway as the soil can generally be easily worked and grass seed will catch easily. In areas with poor drainage, it will be necessary to work during a dry period.
- Vegetated channels should not be subject to sedimentation from disturbed areas. Sediment traps may be needed at channel inlets and outlets to prevent sedimentation.
- Established vegetated channels resemble natural drainage systems and are usually preferred if design velocities are below 5 ft/sec (1.5 m/sec).
- Outlets should function with a minimum of erosion and should be constructed prior to channel construction (see BMP 10 Energy Dissipaters).
- Appropriate soil-stabilization methods, such as mulch, mats or blankets, should be used before establishment of vegetation.
- For design velocities > 0.6 m/sec (2 ft/sec), line the channel with sod or install a suitable erosion control blanket or turf reinforcement mat (see BMP 15 Rolled Erosion Control Products). For design velocities > 1.2 m/sec (4 ft/sec), a suitable permanent erosion control blanket or turf reinforcement mat will be necessary.
- The design water surface elevation of the waterway should be equal to or less than the design water surface elevation of diversions or other tributary channels contributing to water flow.
- Following excavation and grading, the entire channel should be smoothed and compacted to prevent unequal settlement.
- Native grasses develop an extensive root system, but may take several years to become adequately established.
- Select appropriate vegetation and construct channels early in the construction schedule before grading and paving increase run-off rates.
- A stabilized outlet should be constructed prior to operation of the channel.
- It is preferable to use grading equipment to excavate or shape to line, grade and cross section as required to meet criteria.

- The waterway should be free of bank projections or other irregularities, which will impede normal flow. The entire channel should be smoothed and compacted to prevent unequal settlement. Topsoil should be stockpiled and re-spread where necessary to provide a good seed bed. Apply a suitable rate and mix of seed within 24 hours of channel construction and grading.
- Adequate fertilizer should be applied for grass establishment.
- Sodding can provide immediate protection in critical areas. However, mulch or turf reinforcement mat may be used to protect the waterway until the vegetation becomes established.

Inspection and Maintenance

- Regular inspection and maintenance, especially during grass establishment, is important to keep a vegetated channel in good working condition. Bare or eroded spots should be quickly sodded or reseeded.
- Grass provides the primary erosion protection in grass-lined channels. Fertilizing and mowing (with the cuttings removed from the channel) should be done frequently enough to keep the vegetation in vigorous condition.
- After grass has become established, the channel should be periodically checked for debris, scour or erosion and any required repairs made immediately to determine if the channel is withstanding flow velocities without damage.
- Remove significant sediment accumulations to maintain the designed carrying capacity.

Construction Details

Refer to figures:

Grass-Lined Channels: Typical Cross Section

Grass-Lined Channels: Typical Installation

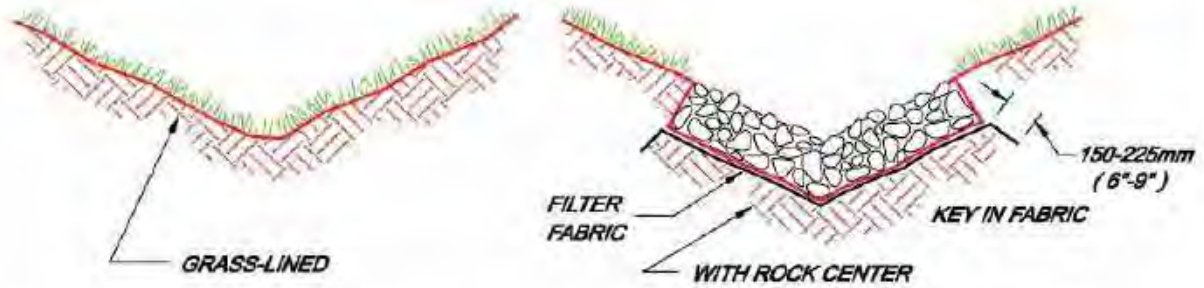

**TYPICAL V-SHAPED CHANNEL
CROSS-SECTION**

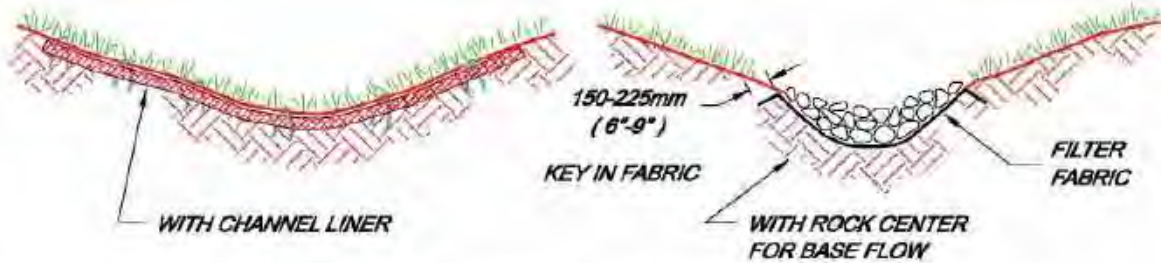

**TYPICAL PARABOLIC CHANNEL
CROSS-SECTION**

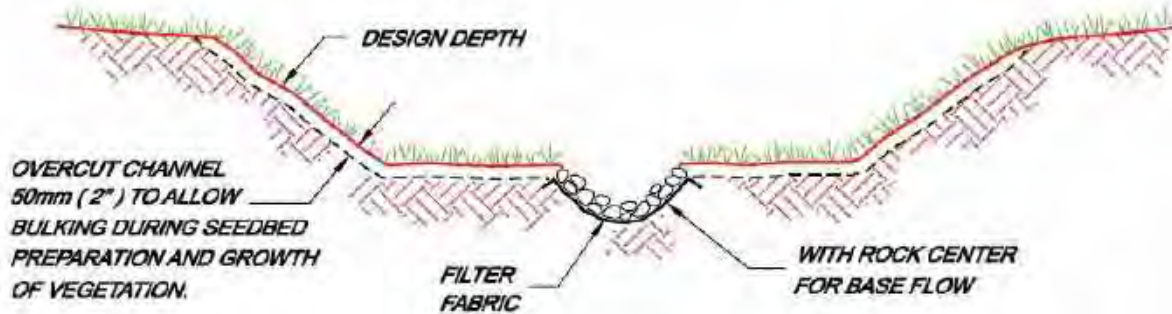

**TYPICAL TRAPEZOIDAL CHANNEL
CROSS-SECTION**

Grass-Lined Channel: Typical Cross Sections



Erosion & Sediment Control Guidelines 2011

Source: Salix Applied Earthcare - Erosion Draw 5.0
© 1995 JOHN McCULLAH FILE: grass_xs.dgn

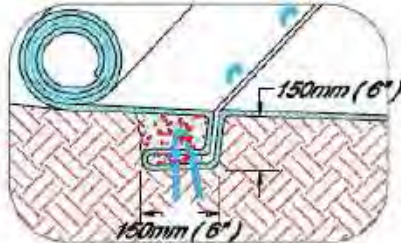
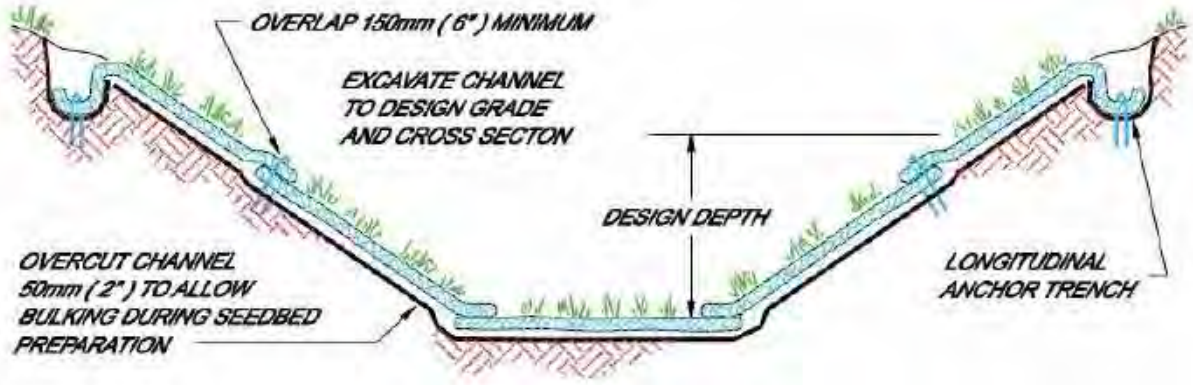

INTERMITTENT CHECK SLOT

TYPICAL INSTALLATION WITH EROSION CONTROL BLANKETS OR TURF REINFORCEMENT MATS

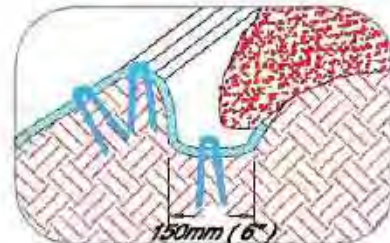

LONGITUDINAL ANCHOR TRENCH

SHINGLE-LAP SPliced ENDS OR BEGIN NEW ROLL IN AN INTERMITTENT CHECK SLOT

PREPARE SOIL AND APPLY SEED BEFORE INSTALLING BLANKETS, MATS OR OTHER TEMPORARY CHANNEL LINER SYSTEM

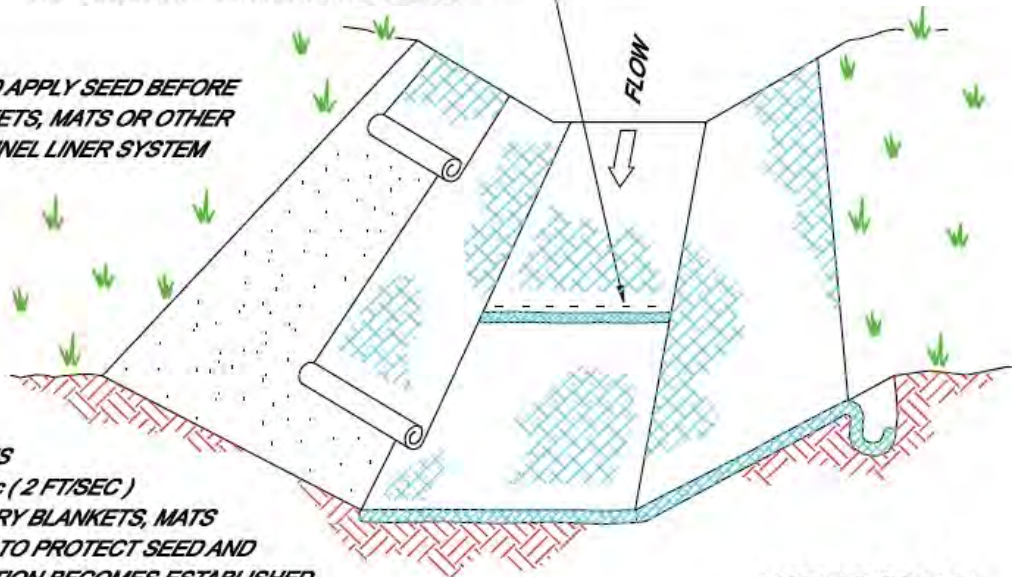

NOTES:

1. DESIGN VELOCITIES EXCEEDING 0.5m/sec (2 FT/SEC) REQUIRE TEMPORARY BLANKETS, MATS OR SIMILAR LINERS TO PROTECT SEED AND SOIL UNTIL VEGETATION BECOMES ESTABLISHED.
2. GRASS-LINED CHANNELS WITH DESIGN VELOCITIES EXCEEDING 2m / sec (6 FT/SEC) SHOULD INCLUDE TURF REINFORCEMENT MATS.

NOT TO SCALE

Grass-Lined Channel: Typical Installation



BMP 8	RIPRAP-LINED CHANNELS	Construction Site Stormwater Conveyance
--------------	------------------------------	--

Description and Purpose

Note: This practice discusses the use of riprap or loose rock channel lining. There are also several commercially available products, many made from pre-cast concrete (i.e. grid pavers, articulating concrete mats, interlocking concrete blocks) which may be suitable alternatives and may be easier to install than riprap. Pre-cast products should be installed following the manufacturer's directions.

Lining ditches channels with riprap (irregular shaped, angular, durable rock) or a suitable hard-armour type product can prevent erosion caused by concentrated run-off (due to turbulence and shear).

- **Stormwater Conveyance**
- **Stripping & grading to Final Stabilization**
- **Temporary or Permanent Measure**

Applications and Advantages

- Generally considered a permanent erosion control measure for channels.
- Riprap or similar linings can be installed relatively easily using heavy construction equipment.
- Suitable for use in channels where the design velocity exceeds that suitable for vegetated linings (channels with highly erodible soils on gradients exceeding 2% and flow velocities ranging from 2 – 5 m/sec).
- Riprap and similar linings can provide a durable, flexible and low maintenance erosion resistant lining.

Design Capacity: Hard armoured channels should be able to handle a 24 hr, 10 year storm.

Side Slopes: 2H:1V or flatter.

Riprap Size/Thickness: Riprap size and thickness in large and critical channels should be designed by a qualified professional. For all other applications, minimum riprap diameter should be 50 mm (2 inch) and the thickness of the blanket should be a minimum 1.5 times the stone diameter (minimum thickness: 150 mm).

Underlay: Specified extra strength geotextile/filter fabric or well-graded granular underlay.

Channel Cross Section: Should conform as shown on plans for design high flow.

Outlet: should be stabilized prior to starting construction of the channel.

Limitations

- Riprap-lined channels generally need to be designed and specified by a qualified professional.
- Riprap or similar linings are expensive (very dependent on rock size, local availability, transportation and handling costs).
- The channel/ditch should be excavated and prepared prior to riprap placement (this includes over excavation of the channel to accommodate the required riprap thickness and the disposal or excavated spoil).

- Riprap and similar linings always require the replacement of an extra-strength, non-woven filter fabric or a gravel blanket underlay to prevent the entrainment and displacement of erodible material from the underlying soil layer.

Implementation

- Always construct a stabilized channel outlet prior to excavating the channel.
- Excavate the channel cross section to the grades shown on plans. Over cut the channel to accommodate the thickness of the rock and filter.
- Place geotextile or a gravel filter layer so as to provide a complete underlay (overlap upstream sections of geotextile over downstream sections).
- Always use well-graded riprap
- Place riprap or hard armour product so it forms a dense, uniform, well-graded mass with few voids. Hand placement of large riprap may be necessary to obtain good size distribution and avoid damage to the underlay.
- No over-fall of channel construction should exist at the outlet (over-falls result in erosive scour). Grass-lined channels with riprap bottoms should have a smooth contact between riprap and vegetation.

Inspection and Maintenance

Periodically inspect channels, especially after intense or sustained rainfall or snowmelt. Look for sediment accumulation, piping and scouring and bank instability. Be especially cognizant of damage at outlets and at points where concentrated flow enters the channel. Document channel condition, remove accumulated sediment and repair damaged areas immediately.

Construction Details

Refer to figure:

Typical Detail for Rock/Riprap Lined Channel

DESIGN HEIGHT (H), WIDTH AND STONE SIZE SHALL BE DETERMINED BY THE ENGINEER.

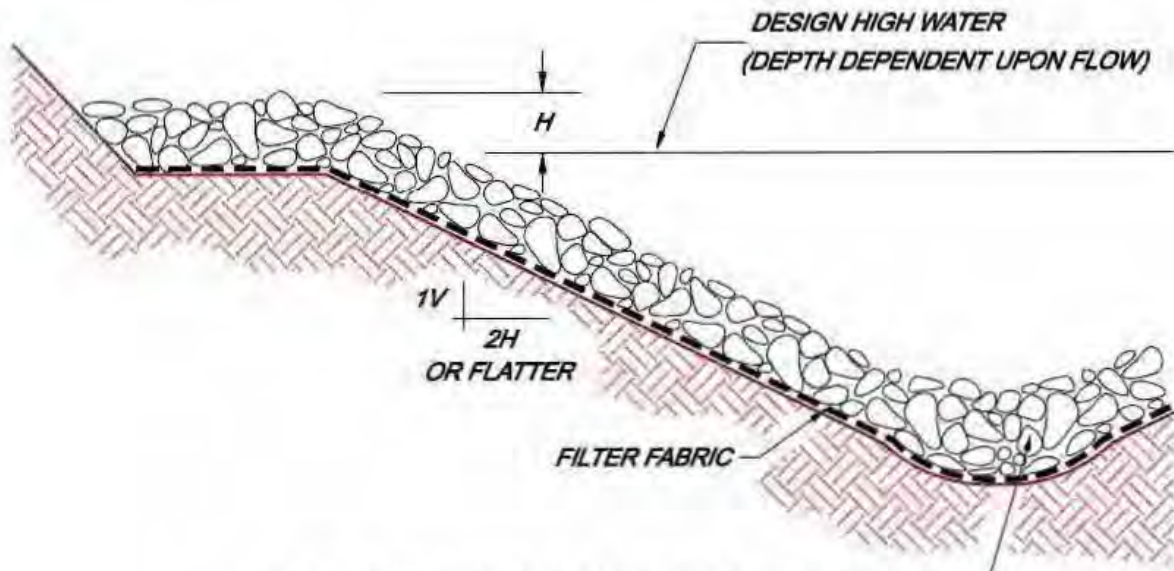

MINIMUM 150mm (6") THICK LAYER OF 50mm (2") MINIMUM DIAMETER DRAIN ROCK. LARGER STONE SHALL BE USED DEPENDENT UPON GRADIENT, SOIL TYPE, AND DESIGN FLOW.

TYPICAL SECTION

Rock Lined Channel



Erosion & Sediment Control Guidelines 2011

Source: Salix Applied Earthcare - Erosion Draw 5.0
© 1994 JOHN McCULLAH FILE: rclchne1.dgn

BMP 9	TEMPORARY SLOPE DRAINS	Construction Site Stormwater Conveyance
--------------	-------------------------------	--

Description and Purpose

Constructed slopes are often exposed to erosion between the time they are graded and permanently stabilized. It may be necessary to convey concentrated run-off down an un-stabilized cut or fill slope, while preventing erosion of the face of the slope. A temporary slope drain is a heavy duty flexible tubing, pipe, over-side drain, or other conduit extending from the top to the bottom of a cut or fill slope.

- **Stormwater Conveyance**
- **Stripping & grading to Final Stabilization**
- **Temporary Measure**
- **Used to Protect Exposed Slopes**

Applications and Advantages

- Temporary slope drains are generally used in conjunction with diversions to safely convey run-off down a slope until permanent water disposal measures can be installed.
- The practice is suitable where run-off that collects above a cut or fill slope, and cannot otherwise be conveyed around the slope, would cause severe erosion if it spilled over the slope.

Limitations

- Pipes, channels or other conduits should be correctly sized, installed and maintained to function at anticipated flow volumes until a permanent slope drain is installed, slopes are stabilized with vegetation and the upstream berm and ditch has been either removed or tied into the permanent drainage system.
- Severe erosion at the drain inlet structure, at the outlet can occur if the slope drain is not properly constructed to a stabilized outlet. Improper sizing or lack of maintenance can cause severe gully erosion.
- Slope drains should be securely anchored to the face of the slope.

Implementation

Materials

Temporary slope drains can be constructed from a variety of materials (i.e. flexible, heavy duty corrugated plastic pipe, corrugated metal culvert pipe or as open top over-side drains). The drainage area is used to determine slope drain sizing. The following information table is from the Alberta Infrastructure and Transportation ESC Design Guidelines for Highways (for information only; slope drain diameter should always be included in a design by a qualified professional):

Minimum Slope Drain Diameter Based on Contributing Area	
Maximum Contributing Drainage Area (ha)	Minimum Pipe Diameter (mm, inside)
0.2	300
0.6	450
1.0	530
1.4	600
2.0	760

Construction

- Construct a temporary diversion ditch and berm along the top of the cut or fill slope to collect and direct run-off (see BMP 6). The top of the diversion berm should be a minimum of 0.3 m higher than the top of the slope drain inlet.
- Construct slope drains and place them on undisturbed soil or compacted fill at the slope locations indicated on the ESC drawing (more than one slope drain may be required if contributing upslope areas are too large for one drain).
- Always extend the drain beyond the toe of a slope and install a suitable energy dissipater (such as riprap, gravel or a concrete splash pad) at the downslope outlet end of all slope drains.
- Construct an interceptor channel, erosion resistant ditch block or other inflow apron structure (as clearly specified in the design) to the slope drain inlet. Slightly slope the inlet structure towards the slope drain. A T-pipe configuration at the inlet can help water to enter the drain and reduce potential scour or undermining. Seepage and scour at the intake structure is a major cause of slope drain failure.
- Install the slope drain and construct a compacted inlet berm (in 150 mm soil lifts) or barrier with a minimum of 0.45 m compacted soil cover above the top of the pipe to secure inlet.
- The side slopes of the cover fill should not exceed a 2H:1V gradient. Stabilize cover with vegetation or other temporary erosion control as soon as the slope drain is constructed.
- Install adequate scour protection (such as riprap at the inlet).
- Secure slope drains in place so as to prevent movement (i.e. steel anchor stakes, hold-down grommets or another approved method), spacing anchors on each side of the slope drain at maximum intervals of 3 m.

Inspection and Maintenance

- Inspect all slope drains and temporary berms, channels, inlet and outlets at least weekly and after all intense or sustained run-off or snowmelt likely to cause erosion.
- Promptly repair any damage to the slope drain, inlet and outlet and remove any accumulated sediment at the slope drain inlet.
- If there is evidence of slope drain movement, install additional anchors.
- Remove temporary slope drains and clean up and stabilize all residual disturbed areas (i.e. seed and mulch) once the permanent drainage system is constructed, temporary berms and channels have been removed and the slope has been stabilized with vigorous vegetation cover.

Construction Details

Refer to figure:

Typical Construction Detail for a Temporary Slope Drain

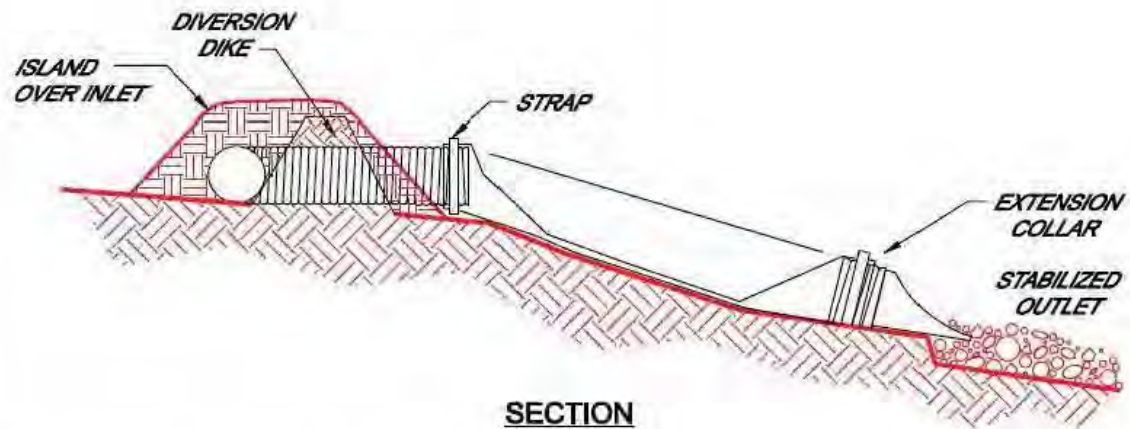
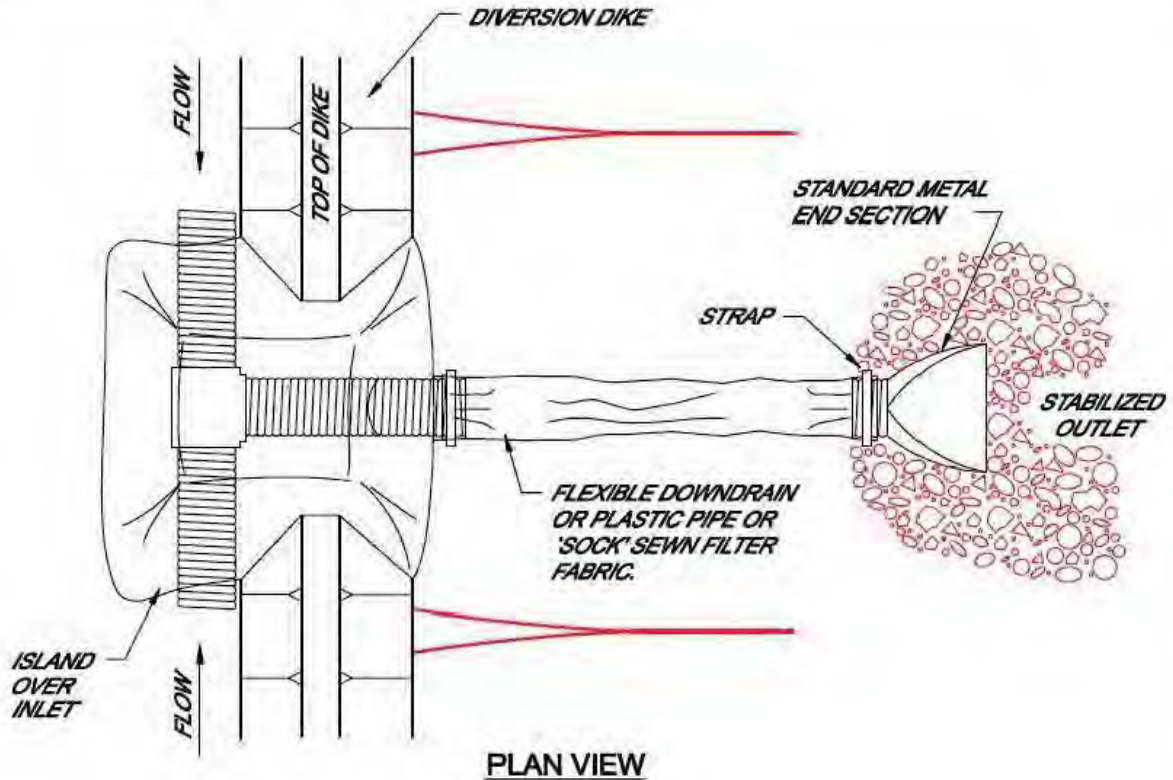

NOTE:

1. THIS FIGURE IS PROVIDED FOR GUIDANCE ONLY AND DOES NOT CONSTITUTE A DESIGN. A SITE SPECIFIC DESIGN IS REQUIRED FROM A QUALIFIED PROFESSIONAL.

Temporary Slope Drain



THE CITY OF
CALGARY
WATER SERVICES

Erosion & Sediment Control Guidelines 2011

Source: Salix Applied Earthcare - Erosion Draw 5.0
© 1994 JOHN McCULLAH FILE: slopedrn.dgn

BMP 10	ENERGY DISSIPATERS	Construction Site Stormwater Conveyance
---------------	---------------------------	--

Description and Purpose

Energy dissipaters are structures/hard armour placed at pipe outlets, in channels, and immediately downstream of check structures to reduce the velocity and dissipate the energy of concentrated water flow, thereby minimizing erosion and scour potential. Energy dissipaters can reduce flow energy in a relatively small area.

- **Stormwater Conveyance**
- **Temporary or Permanent Measure**

Applications and Advantages

- Ensure an appropriate energy dissipater is installed whenever the discharge velocity of a water conveyance exceeds the permissible velocity of the receiving channel or disposal area (i.e. where a lined conveyance channel discharges to an unlined area).

Limitations

- Use adequately sized material (small rocks can be dislodged during high flows).
- Riprap aprons are relatively cheap and easy to install. Many dissipaters can be expensive and labour-intensive to construct
- Use of grouted riprap is not recommended in northern climates due to potential for freeze-thaw damage;
- May be labour-intensive to construct;
- In the case of extreme discharge velocities, riprap may be unsuitable and a special design by a qualified professional will be required.

Implementation

Design Considerations:

Note: Compliance with federal and provincial legislation is critical when working in, or adjacent to, watercourses. During the planning stage, provide any required notifications to regulatory agencies and obtain all required approvals before commencing work.

Design Storm: Design the dissipater to accommodate a ten-year peak run-off event or the design discharge of the channel, whichever is greater.

Riprap Material: Riprap should be comprised of a well-graded mixture of hard, angular, weather resistant stone (predominantly larger stone with sufficient smaller sizes to fill voids). The diameter of the largest stone size should be no greater than 1.5 times the d_{50} size.

Grade and Alignment: Ensure that the dissipater apron has zero grade and is installed so the surface is even with the surrounding ground (avoid any overfall). Ideally, the apron should be straight throughout its entire length: If a curve is necessary to align the apron with the receiving stream, locate the curve in the upstream section of riprap.

Dissipater Length should be sufficient to adequately dissipate energy. Length should be at least 4.5 times the diameter of the pipe or the channel at the outlet, but extend the dissipater downstream until stable conditions are reached. To prevent back scour, the dissipater apron should extend upstream at least

0.5 times the pipe/channel diameter.

Dissipater Thickness should be sufficient to control erosive energy (riprap dissipater thickness should be at least 1.5 times the thickness of the largest rock, with a minimum thickness of 0.3 m).

Dissipater Width should be at least 4.0 times the diameter of the pipe or channel at the outlet.

Underlay: To prevent erosion of fine material under a riprap dissipater, always install an underlay of heavy duty, non-woven geotextile or a layer of well-graded sand and gravel (at least 150 mm thick).

Construction

- Outlets of all water conveyances should be stabilized to prevent scour erosion.
- Grade the area to final design grades and elevations and excavate at the dissipater location to the required grade for dissipater placement. Compact the sub-grade to the density of the surrounding undisturbed material.
- Install a geotextile fabric or sand/gravel filter underlay.
- Install riprap in accordance with the specified grading limits shown on the construction drawings.
- To prevent damage to the geotextile fabric, a combination of machine and hand placement of riprap is required. Repair any damaged fabric by removing the riprap and placing another piece of fabric over the damaged area. Overlap all fabric joints a minimum of 0.3 m.

Inspection and Maintenance

- Periodically inspect riprap outlet structures for damage (at least monthly and following significant rainfall or snowmelt likely to cause erosion). Repair damage immediately.
- Energy dissipaters are generally permanent, so do not require removal unless specified.
- It may be necessary to periodically clean energy dissipation controls when voids become filled with sediment and debris.

Construction Details

Refer to figure:

Typical Installation Detail for Energy Dissipater

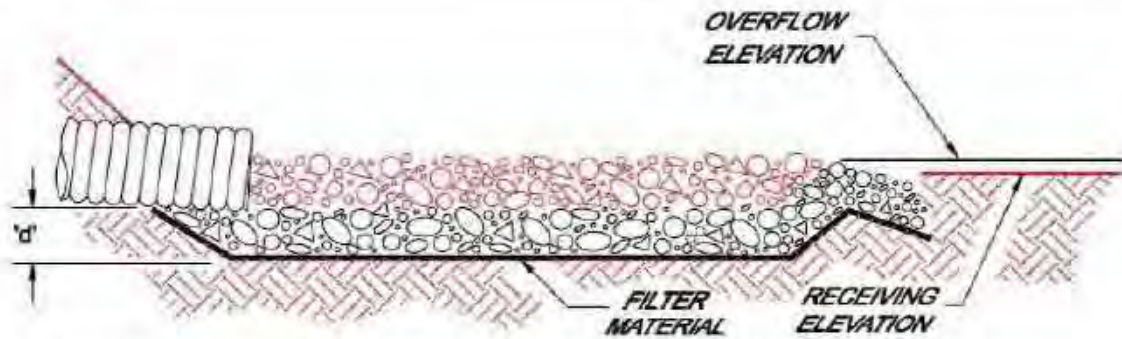

THICKNESS ('d') = 1.5 x MAX. ROCK DIAMETER - 150mm (6") MIN.

SECTION

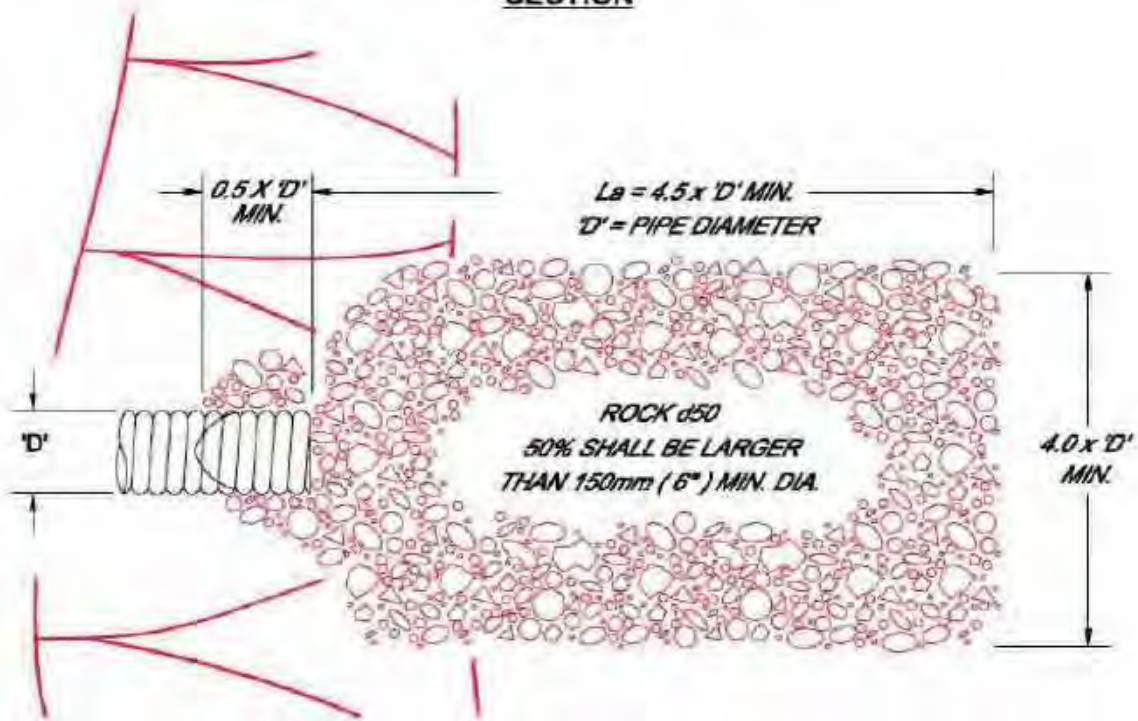

PLAN

NOTES:

1. *'La'* = LENGTH OF APRON. DISTANCE '*La*' SHALL BE OF SUFFICIENT LENGTH TO DISSIPATE ENERGY.
2. APRON SHALL BE SET AT A ZERO GRADE AND ALIGNED STRAIGHT.
3. FILTER MATERIAL SHALL BE FILTER FABRIC OR 150mm (6") THICK MINIMUM GRADED GRAVEL LAYER.

Energy Dissipator



Erosion & Sediment Control Guidelines 2011

Source: Salix Applied Earthcare - Erosion Draw 5.0
 © 1994 JOHN McCULLAH FILE: enrgydis.dgn

BMP 11	CHECK DAMS	Construction Site Stormwater Conveyance
---------------	-------------------	--

Definition and Purpose

Note: Silt fence and straw bales must not be used in areas of concentrated run-off

The Primary purpose of check dams is to prevent erosion by decreasing velocity of run-off in a channel (sediment control is not the primary purpose of check dams). A secondary benefit of properly installed and maintained check dams is the temporary detention of run-off, allowing settling of coarse sediment (note that, if not frequently removed, settled sediment may subsequently be re-suspended).

Check dams can be constructed from a variety of materials (including suitable rock, sandbags, compost filter socks, straw wattles, triangular silt dike and synthetic permeable barriers). As there are a number of different products suited to different situations, the purpose of this information is to provide general guidance on the application, installation, inspection and maintenance of check dams.

- **Stormwater Conveyance**
- **Stripping & grading to Final Stabilization**
- **Generally a Temporary Measure. Rock Checks can be Designed as Permanent**

Applications and Advantages

- Generally used as a temporary structure (rock checks may be permanent), where the length of service does not warrant the more expensive installation of channel linings.
- Intended to provide erosion control by decreasing run-off velocity in a defined channel.
- Check dams provide grade control by flattening the effective grade of the channel.
- Check dams can provide ponding in low-flow situations, providing relatively good settling of coarse sediment settling and promoting infiltration. Sediment may be re-suspended during higher flows.
- Best used in conjunction with rolled erosion control products.

Limitations

- For higher flows, water should be able to flow over (not around) check dams.
- Silt fence and straw bales are not suitable for use as check dams.
- Properly constructed and spaced check dams can reduce channel erosion, but provide minimal sediment control (sand and coarse silt may be retained, but run-off detention time is usually too short to allow fine sediment to settle).

• Note: Check dams are only suitable for limited drainage areas: Rock check dams are suitable for channels draining areas < 4 ha; other materials (sandbags, wattles, compost socks, synthetic check dams) are suitable for channels draining areas < 2 ha.

- Check dams should not be used in live streams/channels with extended base flows.
- Check dams may reduce the hydraulic capacity of the channel.

- Creation of turbulence downstream can cause erosion of the channel banks/base (incorporate a non-erosive lining such as a section of RECP immediately downstream of a check dam).
- Check dams should not be used in channels that are already grass-lined, unless erosion is expected. Pondered water may kill grass in grass-lined channels.
- Permanent check dams may obstruct construction and ditch maintenance (i.e. cleaning, mowing).
- Severe erosion can occur if dams are undermined or outflanked (water flows under or around the structure).
- Synthetic barriers can become brittle in winter and/or may be subject to traffic and snow damage when used in highway applications.
- Structures/material should be able to resist displacement by flowing water.
- Check dams may require extensive maintenance following large rainstorms or run-off events. Timely removal of accumulated sediment is necessary.

Implementation

Note: Due to the variety of materials used to construct check dams, guidance is only provided for rock check dams and synthetic permeable barriers. Always consult a qualified professional for a site-specific design.

Rock Check Dams

- Rock check dams should consist of clean, free-draining, well-graded aggregate, large enough to remain in place during high flow conditions. It is important that a mix of sufficient size rocks be used to ensure the stability of the structure. Where low flows are expected, mean rock diameter (D_{50}) should range from 75 – 150 mm. For higher flows, larger diameter rock should be used and the structures designed by a qualified professional.
- If constructing a series of check dams, the height and spacing between structures should be designed to reduce channel gradient to intervals of flatter gradient. Always ensure the bottom of the upstream check dam is the same elevation as the top centre of the downstream check dam.
- Excavate a trench perpendicular to the channel flow line (minimum 0.15 m depth), line the footprint with non-woven geotextile fabric and place rock (hand or machine-place; do not dump).
- Build up the structure by machine-placing and hand-placing rocks, ensuring that the structure extends a minimum of 450 mm beyond the tops of the channel banks. The flow-line (dam centre) should be least 300 mm below the elevation of the dam edges (this will allow water to flow over the structure rather than around it).
- The height of structures should be less than 0.8 m (to avoid impounding large volumes of run-off).
- The upstream slope of the check dam should be 2H:1V (minimum) and the downstream slope 3H:1V (minimum).
- Dams should be spaced so that the top elevation of each downstream dam is the same as the elevation of the toe of the adjacent upstream dam.
- The channel downstream of the lowest dam should be protected against erosion.
- Ensure that the upstream contributing area and channel reach is stabilized.

Synthetic Permeable Barriers

- Double panel or triangular panel low profile, porous synthetic barriers can also be used to dissipate run-off flow energy and velocity. Panels are patented designs, constructed with durable, lightweight

synthetic materials, and designed to be reusable. Barriers manufactured from biodegradable material are also available.

- By reducing flow energy and velocity, these barriers can enable some settling of coarse sediment and provide temporary stabilization of lower gradient channels during vegetation establishment.
- Install synthetic barriers as per the manufacturer’s recommended instructions.
- Synthetic barriers are generally used in conjunction with an appropriate RECP (to provide intimate ground contact between the soil and the base of the barrier, reduce potential undermining and to provide a splash pad immediately downstream of the barrier).
- Ensure the side panels of synthetic barriers are extended to a sufficient height on the outside of channels (to provide sufficient freeboard for channel flow).
- Maximum spacing of a series of synthetic barriers should ensure that the bottom elevation of the adjacent upstream barrier is the same as the top elevation of an adjacent downstream barrier.
- Barriers should be well anchored with pins (as recommended by the manufacturer).

Maximum Spacing for Check Dams

Source: California Stormwater Quality Association

Ditch Grade	Minimum Weir Depth		
	150 mm	300 mm	450 mm
6 %	Not Recommended	4.5 m	7.5 m
5 %	Not Recommended	6.0 m	9.0 m
4 %	Not Recommended	7.5 m	12.0 m
3 %	4.5 m	10.5 m	15.0 m
2 % or less	7.5 m	15.0 m	24.0 m

Inspection and Maintenance

- Prior to permanent stabilization (and except during freeze-up), inspect all check dams and drainage channels at least weekly and after significant rainfall snowmelt likely to cause erosion.
- Repair all damage immediately. If significant erosion occurs between the dams, additional protection may be required (i.e. riprap lining, RECPs, additional check dams).
- Remove sediment behind the dams when it reaches 1/3rd the height of the centre elevation or as needed to prevent damage to channel vegetation and to maintain drainage through the structure.
- For rock check dams, add or remove rock to dams as needed to maintain design height, cross section and flow. Replace dislodged aggregate with heavier aggregate.
- Be careful not to damage check dam structures during sediment removal.

Construction Details

Refer to figure:

Rock Check Dam and Synthetic Permeable Barrier

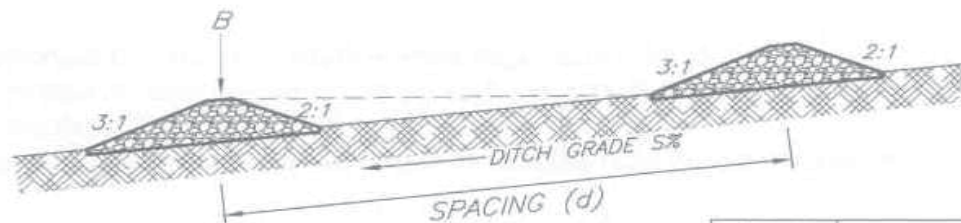
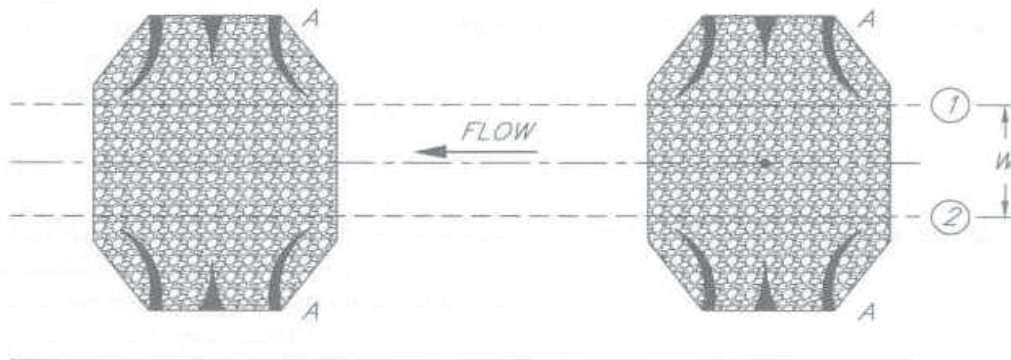
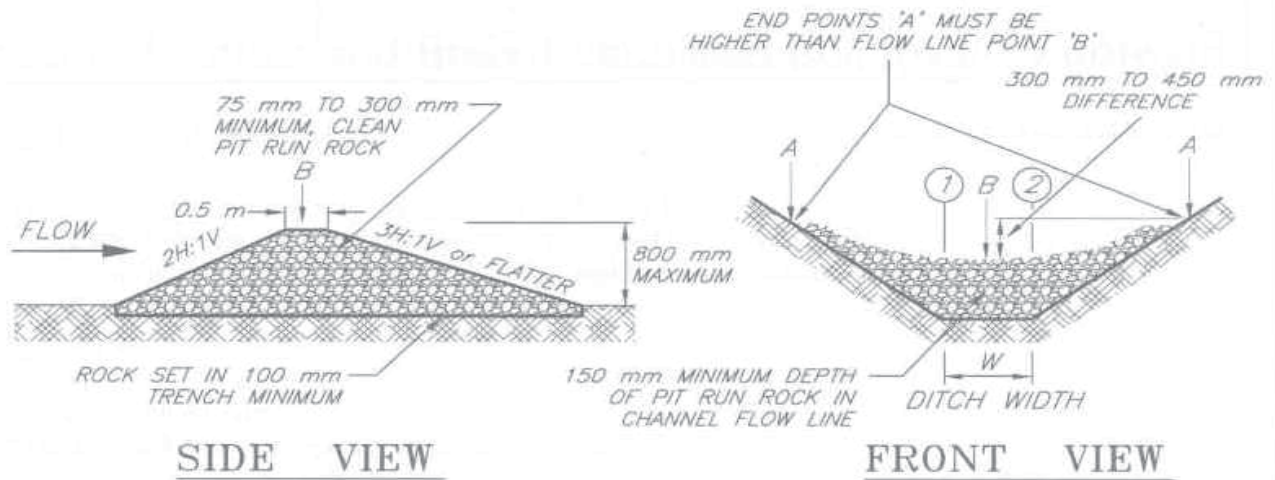

NOTES:

1. SUITABLE FOR FLOW VELOCITY ≤ 1.5 m/s.
2. SUITABLE FOR DRAINAGE AREA ≤ 4 ha.
3. SUITABLE FOR GRADES FROM 5% TO 8%.
4. SPACING (d) AND ROCK SIZE (D_{50}) TO BE DETERMINED BY ENGINEER BASED ON HYDRAULIC CONDITIONS.
5. THIS FIGURE IS PROVIDED FOR GUIDANCE ONLY AND DOES NOT CONSTITUTE A DESIGN. A SITE SPECIFIC DESIGN IS REQUIRED FROM DESIGNER/ENGINEER.

D_{50} of ROCK (mm)	MAXIMUM FLOW DEPTH OVER ROCK (mm)
75	50
150	100

SUGGESTED ROCK DIAMETER AND OVERFLOW DEPTHS

ROCK CHECK DAM

NOT TO SCALE

Source: Alberta Transportation; Design Guidelines for Erosion & sediment control for Highways. 2003

BMP modified from the City of Calgary - Guidelines for Erosion & Sediment Control (2011 Edition) Appendix A Best Practices For Controlling Erosion and Sedimentation on Urban Construction Sites

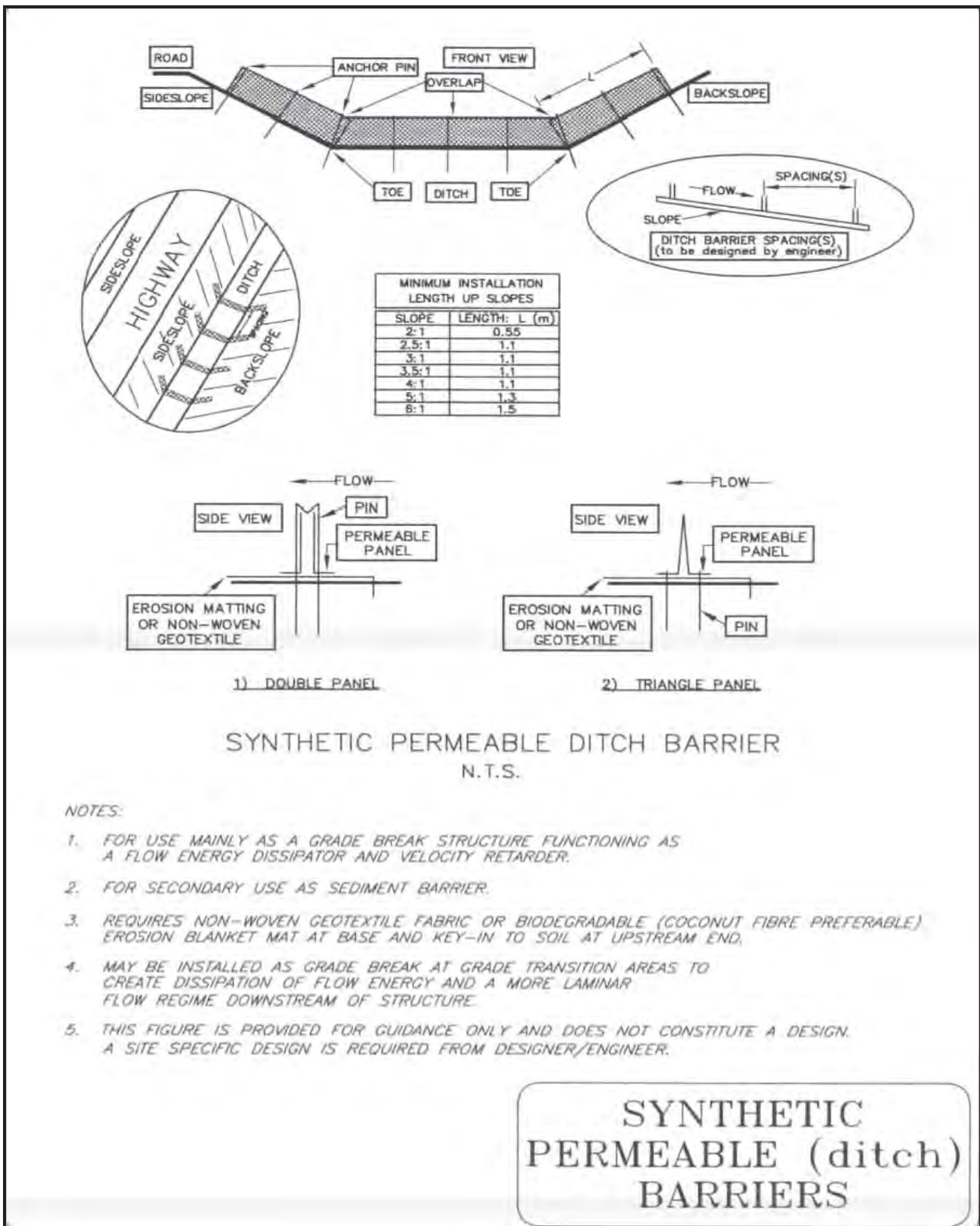

Source: Alberta Transportation; Design Guidelines for Erosion & sediment control for Highways. 2003



A system of well-installed rock check dams (properly spaced and extended up the sides of the channel) on a road construction project.



Ditch checks can be subject to washout and undermining if not properly installed (spacing, anchoring, and configuration) or used as part of a system of erosion & sediment controls.

BMP 12	SEEDING AND SODDING	Erosion Control
---------------	----------------------------	------------------------

Note: Before applying soil amendments, seed or sod to a site, always consult and adhere to local requirements and specifications for public lands. Always consult a local erosion control specialist or agronomist familiar with area soils, climate and local seeding requirements and mixes. Contractors must have experience at performing the type and scale of work required.

BMP 12a: Seeding

Description and Purpose

The planting or placing of seed on disturbed soil after disturbed areas have been topsoiled or otherwise prepared for seeding. Seeding can provide both temporary and permanent cover and root structure to provide effective erosion control.

- **Temporary or Permanent Measure**
- **Use from Stripping and Grading to Final Site Stabilization**
- **Slopes, Stockpiles (Seeding), Borrow Areas, Landscaping**

Important Definitions

Established Vegetation: The point at which individual plants and plant cover are self-sustaining, providing dense vigorous cover.

Dormant Seeding: Refers to permanent seeding of final topsoiled grades in the fall/early winter (once temperatures are consistently low enough to prevent seed germination). The area is seeded with a permanent mix, fertilized and then protected with erosion control blanket or mulch. The seed remains dormant until soil temperature is warm enough in the spring to trigger germination and growth. This approach is used to eliminate seeding delays in the spring.

Surface Roughening: Harrowing or lightly tracking the soil surface up and down a grade can improve seed to soil contact and provide seedling safe sites (shade and moisture retention).

Pure Live Seed (PLS): PLS is an indicator of seed mix quality, based on seed purity and percent germination.

Temporary Seeding: Temporary seeding and mulching (or suitable temporary soil stabilization practices) are generally required for all exposed soils expected to be undisturbed for more than 30 days.

Permanent Seeding: Permanent seeding (along with temporary erosion control(s) to allow time to establish vegetation cover) is generally required for all exposed soils expected to be undisturbed for one year or more or for developing permanent vegetation cover compatible with the intended site use and adjacent areas.

Annual + Perennial Seed Mixes: In some cases, it is desirable to have both suitable annual and perennial species in a seed mix. The annual species are expected to provide temporary vegetation cover (erosion control) while the slower-developing perennial species develop.

Applications and Advantages

- Temporary seeding is used on suitable interim areas that are disturbed and require temporary protection. Temporary seeding is encouraged whenever possible to help reduce erosion on construction sites. Temporary seeding is an important component of "phased" construction activities.

Common areas for temporary seeding include topsoil stockpiles, rough graded areas, berms and other temporary earthen structures.

- Permanent seeding is applied to exposed areas which have been graded to final contour, prepared and topsoiled (i.e. prepared slopes and channels or exposed areas which are to be left dormant for a year or more).
- To provide temporary erosion control during vegetation establishment or to enhance the erosion control function provided by vegetation cover, it is often beneficial to employ suitable mulches or rolled erosion control products (RECPs) in combination with seeding.
- Perennial grasses, when used with turf reinforcement mats (TRMs), provide a fibrous root network (which helps anchor the TRM). These practices can greatly increase the maximum permissible velocities and are useful in stabilizing channels.
- Perennial grasses and legumes improve wildlife habitat and aesthetics.
- Establishing vegetation cover on exposed soils helps protect soil from erosion by raindrop impact, increases infiltration and reduces run-off. After establishment, temporary seeding can reduce sheet erosion by approximately 90% compared to exposed soil conditions (usda, scs, 1976).
- Temporary seeding can reduce maintenance costs for other site controls (i.e. sediment basin maintenance (clean-out) can be significantly reduced if temporary vegetative cover is established in the contributing drainage area). Temporary vegetation cover is also essential to protecting the integrity of other earthen structures used to control sediment (i.e. diversion and containment berms, compost berms).
- Seeding disturbed areas with a suitable mixture of grasses and forbs provides an inexpensive method of stabilizing soils.
- Established vegetation can act as a filter, trapping suspended sediment carried by run-off.

Limitations

- Establishing vegetation cover with temporary seeding can be difficult in northern climates (dry, cool, short growing season). Seasonal planting windows may not coincide with the construction schedule.
- Establishing vegetation cover on steep slopes may require additional - and sometimes expensive - measures such as compost blankets, RECPs or hydromulching.
- Vegetation may require regular maintenance, especially adjacent to roadways.
- Reseeding and amendments may be required where there is poor vegetation establishment.
- Seeded areas may require temporary irrigation until self-sustaining vegetation cover is established.
- Seeding is not appropriate for areas impacted by construction activities/traffic.

Implementation

Timing

- Apply temporary seeding on suitable disturbed areas that will lie dormant for 30 days to one year. Apply permanent seeding on areas left dormant for 1 year or more or when no further disturbances are planned. In order to prevent costly maintenance operations on other erosion & sediment control practices, permanent vegetative cover should be established in phases; that is, as work is completed on upslope areas, permanent seeding practices are then applied to stabilize these areas.
- Permanent seeding is best done spring (prior to thunderstorm season) or in the fall.
- Seed blends for permanent seeding should typically include annuals, perennials and legumes.

- Seed rates for temporary and permanent seeding should be based on a PLS of 80%.
- If seeding occurs after the 50% frost probability date for the site, a dormant seeding method should be used; the seed should be applied late in the season when there is no chance of germination, and applied with a seed drill so cold temperatures do not damage the seed.

Site Preparation

- For permanent seeding, confirm areas to be seeded will be dormant for one year or more or are at final contour and are ready for permanent seeding.
- Ensure concentrated run-off is being diverted away from all exposed slopes and areas to be seeded.
- Conduct soil tests to determine pH and nutrient content, then determine requirements for suitable soil amendments.
- For soil that is compacted, crusted or hardened, the soil should be loosened (with discing, raking or harrowing) and machine-tracked (refer to BMP..., Surface Roughening). Hydraulic planting generally requires less seedbed preparation (generally suited to slopes steeper than 2H:1V, where seedbed preparation is difficult).
- Seed to soil contact is the key to good germination. Prior to permanent seeding, prepare firm (but not compact) seedbed, 75 - 125 mm deep, with at least 75 - 100 mm topsoil depth (or as otherwise specified). The seedbed should be free of large clods and large stones. The prepared surface should be in reasonably close conformity to the lines, grades and cross sections shown on the grading drawings.

Seeding/Amendments

- All seed, fertilizer, mulch and other materials should be clearly marked and available for inspection (contents, weight, analysis, supplier, manufacturer) and tags should be kept by the project manager.
- To reduce requirements for pesticides and fertilizer/other amendments, choose adapted plant varieties based on environmental conditions, vegetation management needs and the intended site use. Legumes should be inoculated with plant-specific *Rhizobium sp.* bacteria before planting (either as pellet inoculated seed or inoculation in the field).
- Use certified Canada No. 1 seed, free of disease, weed seeds or other foreign materials, and meeting the requirements of the Seeds Act.
- Seed should have a minimum acceptable pure live seed (PLS) of 80%. This is calculated by multiplying the minimum seed purity (%) and the minimum germination (%) rates from the seed tag. Divide by 100 to get the % PLS.
- Seed to soil contact is the essential for good germination.
- Apply seed immediately after seedbed preparation while the soil is loose and moist. If the seedbed has been idle long enough for the soil to become compact, the topsoil should be harrowed/loosened.
- Always apply seed before applying mulch.
- Uniformly apply seed at the rates specified in the landscaping or erosion control plan.
- Apply fertilizer as specified. For broadcast seed applications, lightly rake seed and fertilizer into the soil by raking, chain dragging or other suitable means.

- Broadcast seed should be incorporated into the soil by raking or chain dragging, and then lightly compacted to provide good seed-soil contact.
- Apply mulch, tackifier, RECP or other specified material over the seeded areas.

Inspection and Maintenance

- Seeded areas should be inspected frequently, especially after significant run-off. If the seeded area is damaged due to run-off, immediate repairs should be made and additional stormwater control measures may be required.
- Frequently evaluate germination and seedling density. Spot seeding can be done on small areas to fill in bare spots where grass did not grow properly.
- Temporary vegetated areas should be maintained until permanent vegetation or other erosion control practices can be established.
- Noxious weeds may need to be controlled by mowing or spraying. Mowing grass will encourage the establishment and spread of the grass.

BMP 12b: Sodding

Description and Purpose

Grass sod can be used to immediately cover and stabilize exposed soil, allowing rapid establishment of vegetation cover where seeding is not practical. The use of sod is generally much more expensive than seed; however, it has an immediate effect. In addition to providing rapid erosion control, sod can also be used to provide a protective vegetated buffer adjacent to sensitive areas (such as water bodies). Sod may be nursery or field sod composed of one or more species/cultivars of grasses and may contain associated plants such as legumes.

Applications and Advantages

- As a temporary or permanent measure.
- May be used to immediately protect soil surfaces from water and wind erosion where adequate topsoil, fertilizer and water for irrigation can be provided.
- Aesthetically pleasing erosion control and landscaping for single family lots.
- As a protective buffer around water bodies and other sensitive areas.

Limitations

- Irrigation (watering) is required after placement and until rooting is established.
- Expensive and fairly labour intensive to install.
- Suitable sod may not be readily available.
- Field sod is not specifically produced for sale as turf and is generally not certified as to its composition or degree of weed infestation.
- Sod cannot be stored on-site for long periods of time

Implementation

- Sod should not be laid on frozen ground surfaces.
- During dry, hot weather, the ground surface should be cooled using irrigation before laying sod.
- Freshly installed sod should be irrigated to moisten the topsoil to minimum depth of 0.1 m. Irrigation aids in the development of roots within the topsoil.
- Successful installation requires the use of freshly cut, healthy sod. Minimize storage time.
- Only apply sod during favourable weather conditions and in accordance with good horticultural practice.
- Prepare a smooth ground surface by removing large rocks, debris and other materials greater than 50 mm in diameter.
- Grade the surface to the final elevations, grades and cross-sections indicated on grading plans.
- Less than 48 hours prior to sod application, apply a slow release NPK 2-4-1 fertilizer (i.e. 12-25-10) at a rate of 175 kg/ha of phosphorous. Nitrogen make-up should be 50% water soluble and 50% slow release. Fertilizer application may be subject to adjustment based on the time of year, receipt of topsoil analysis and contractor recommendations.
- Lay sod strips on the prepared surface with long axis perpendicular to direction of slope (or in channels, perpendicular to anticipated direction of flow).
- Butt the joint ends of adjacent sod strips tightly together.
- Roll or tamp each sod strip firmly to ensure continuous contact between topsoil and underside of sod strip.
- On steep or unstable slopes, secure each strip of sod with an anchor embedded a minimum of 0.15 m into underlying soil. Anchors should be spaced a maximum distance of 0.6 m apart.
- Adjacent rows of sod strips should have staggered joints.

Inspection and Maintenance

- Inspect sodded areas at least weekly for the first two months after placement and after significant storm events or snowmelt likely to cause erosion.
- Areas damaged by washout or rilling should be re-graded and re-sodded immediately.
- Small bare spots may need to be re-sodded.
- Depending on the location and maintenance plan, sodded areas should be maintained by periodically fertilizing, irrigating, mowing and controlling weeds.
- Sod should not be mowed within one month of installation.

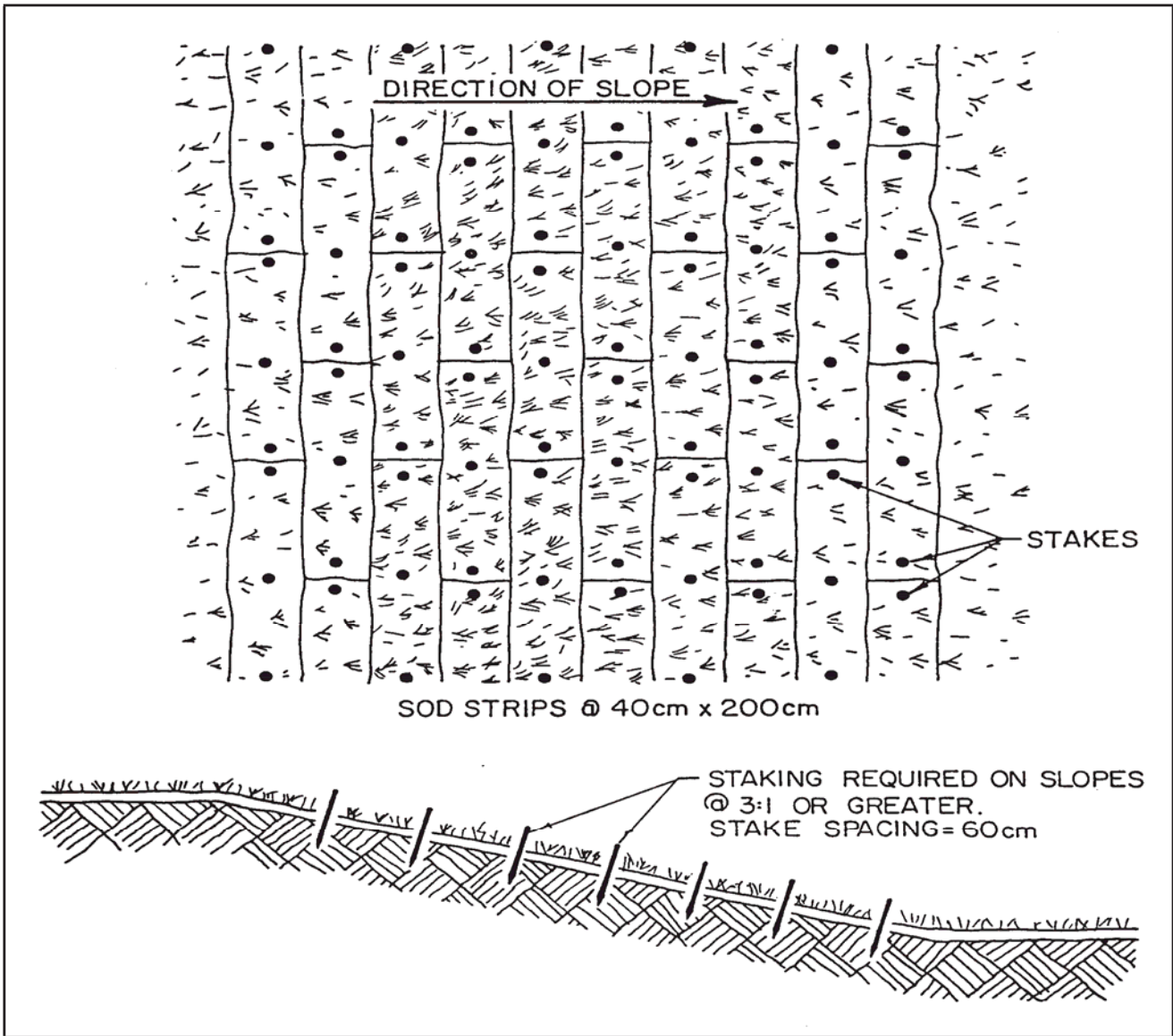

Typical Installation Detail for Grass Sod

BMP 13	MULCHING	Erosion Control
---------------	-----------------	------------------------

Note: Before applying mulch, seed or soil amendments to a site, always consult and adhere to local requirements and specifications. Always consult a local erosion control specialist or agronomist familiar with area soils, climate and local seeding requirements and mixes. Contractors should have experience at performing the type and scale of work required.

Description and Purpose

Mulching is the application of a protective layer of straw/other suitable material to exposed soil surfaces. Straw mulching and/or hydromulching is also used in conjunction with seeding and hydroseeding of critical areas to provide temporary erosion control and promote the establishment of vegetation. Mulching with straw or fiber mulches is also commonly used as a temporary measure to protect bare or disturbed soil areas that have not been seeded. In addition to absorbing raindrop impact and reducing soil erosion, suitable mulches can also help conserve soil moisture, moderate soil temperature, increase infiltration and protect seeds from predators, run-off and wind.

- **Erosion Control Mulches are a Temporary Measure**
- **Use on Slopes, Stockpiles and Other Exposed Soils from Clearing and Grubbing to Final Stabilization**

Mulches can be classified as “dry” (i.e. straw, compost, wood chips, RECPs, rock) and “wet” (i.e. wood fibre and paper slurry applied by hydraulic equipment). Straw mulching consists of placing a uniform layer of straw and binding it onto the soil with suitable devices. Hydraulic mulching typically consists of applying (using hydromulching equipment) a matrix of shredded wood fibre (or other suitable fibre), emulsifying agent and tackifier.

Applications and Advantages

- There are a large variety of mulches available for application on a range of slopes and soil types.
- Mulch application provides a relatively low-cost method of controlling erosion and/or promoting plant growth.
- Mulching is most commonly used to provide temporary stabilization of soil, usually until permanent stabilizing vegetation is established.
- On steep slopes, greater than 2.5H:1V, or where the mulch is susceptible to movement (by wind or water), consider hydraulic mulch application, application of a tackifier on the mulch or mechanical anchoring (i.e. straw crimping).
- To promote vegetation development and provide temporary erosion control, mulches can be applied after seeding (or, in the case of hydroseeding; during seeding). Where mulches are used to compliment vegetation establishment, they should be designed to last as long as it takes to establish effective vegetative cover for erosion control.
- Straw mulch is suitable for application to disturbed areas requiring temporary erosion control. Straw mulch is suitable on slopes where moderate rill erosion may occur. Straw mulch can be used in combination with temporary and/or permanent seeding strategies to enhance plant establishment.

- Hydraulic mulch is suitable for soil disturbed areas requiring temporary protection until permanent stabilization is established, and disturbed areas that will be redisturbed following an extended period of inactivity.

Limitations

- Mulches should be anchored on steep slopes (2.5H:1V or steeper) and/or where they are susceptible to movement by wind/water.
- Punching/crimping of straw may be difficult in sandy soils.
- Certain mulches may be unavailable or too expensive in some areas.
- Cost-effectiveness of mulching large areas can decrease if mulching by hand.
- Long-term erosion control may not occur if the mulch does not provide the required protection time for the establishment of long-term vegetation cover.
- Some mulches (i.e. wood chips, rock cover) may prevent (or slow) vegetation establishment.
- Organic mulches are not suitable for application if delivered in a wet or moldy state.
- Some organic mulches may contain weed seed (i.e. hay) and unwanted plant material.

Implementation

Where feasible/desirable, suitable vegetation should be shredded during clearing activities, providing a local supply of mulch (economical, plus it may provide a reservoir of local seeds).

Site Preparation

- Fine-grade the area of exposed soil.
- Remove large rocks, clods and debris that may prevent contact of the mulch with the soil surface.
- When seeding, follow the guidance in BMP 12 (Seeding).

Mulch Installation

Straw Mulching:

- The length and bulk of cereal straw makes it an excellent mulching product (reduces raindrop impact and moderates soil surface microclimate).
- Straw is weed free, light and readily available in small and large bales.
- Hay should not be used as mulch (contains weed seeds and may attract wildlife).
- For seeded sites, apply 3,500 – 4,500 kg/ha, aiming for 80% cover.
- For unseeded sites, mulch at 4,500 – 6,500 kg/ha, aiming for 90% cover.
- A standard square bale (about 35 kg) covers approx. 90 m².
- For this practice to be effective, care should be taken to ensure that straw mulch is in close contact with the soil (rather than just providing cover).
- Straw mulch can be applied by hand or using a straw blower (can blow straw 50 – 80 feet).
- Straw placed on exposed areas and on slopes steeper than 2.5H:1V should be anchored.
- Anchor straw by machine tracking, crimping (weighted disks used to force/punch the fibres into the ground), applying a tackifier or netting (specify netting judiciously as birds, snakes and small

mammals can get trapped in certain netting).

Compost (see Compost Blankets)

For Hydraulically Applied Mulches, see Hydromulching and Hydroseeding.

Inspection and Maintenance

- Except during freeze-up and until permanent vegetation cover is established, inspect a minimum of every seven days and after significant rainfall or snowmelt likely to cause erosion or damage to the mulch.
- Verify supplied materials and application meets site-specific specifications. Keep certification tags available for inspection.
- Areas where erosion is evident should be repaired as soon as possible. Care should be exercised to minimize the damage to protected areas while making repairs.
- Ensure that the integrity of the mulch is sufficient to provide the required period of temporary control.

BMP 14	HYDROMULCHING AND HYDROSEEDING	Erosion Control
---------------	---------------------------------------	------------------------

Note: Retain the professional services of a consultant/designer specializing in erosion & sediment control, landscape design or agronomy and an experienced hydromulching/seeding contractor.

Description and Purpose

By using hydraulic equipment (hydroseeders and hydromulchers) seed, soil amendments, fibre mulch, and tackifiers can be uniformly broadcast, as a hydraulic slurry, onto the soil. Applying these materials as a water-based slurry (often in one application) can provide a cost-effective means of erosion control and/or revegetation.

Hydraulically applied mulches form a continuous blanket on the soil surface, protecting the soil from raindrop impact and wind erosion, conserving soil moisture, reducing soil crusting and increasing infiltration. This results in improved conditions for seed germination and plant growth.

- **Temporary or Permanent Measure**
- **Use for areas that are disturbed, but will remain inactive for a while (such as slopes, stockpiles)**

Applications and Advantages

- Hydromulching: The slurry applied to the soil includes mulch (typically wood or paper fibre) and tackifier only (seed and soil amendments are not included).
- Hydroseeding: The slurry applied to the soil typically consists of seed, fertilizer, mulch, tackifiers and other specialized soil amendments.
- Hydromulching/hydroseeding is useful where it is desirable to apply a number of complementary erosion control materials and soil amendments in one (or more) applications.
- On steep slopes, other seeding methods may be unsafe or impractical. These methods are especially suitable for slopes steeper than 3H:1V where an adequate seedbed cannot be prepared and mulch is difficult to anchor.
- Useful for rocky soils, irregular soil surfaces or partially vegetated areas where installation of RECPs is precluded.
- Useful for critical sites that require multiple steps to maximize erosion control.

Limitations

- Requires specialized equipment to mix and apply the slurry.
- Not practical where hydromulching/seeding equipment cannot access the site (equipment is usually truck-mounted and hose range is limited to 150 m).
- Areas where seeding is not successful often require re-application or additional amendments.
- If applied in the same application, seed can be suspended in the mulch blanket and prone to desiccation during periods of drought (for rough/rocky sites, it is beneficial to hydroseed in a two or three-step application).

- Due to mechanical damage to seeds, higher seeding rates are typically required when compared to conventional cyclone or drill seeding (if seed mix includes native seed, this could add substantially to cost).
- Natural mulches will decompose faster than synthetic ones. Ensure the expected mulch life will exceed time required for vigorous vegetation establishment.
- Hydraulic matrices need at least 24 hours of curing/drying prior to precipitation.

Implementation

- In order to select appropriate hydroseeding/mulching materials, the designer should assess how the application will work with the construction schedule as well as water availability, soil conditions, topography and climate.
- Where possible, prepare a seedbed before hydroseed application.
- All legume seed should be inoculated. For pellet inoculated seed, hydroseed application should be done as quickly as possible after the seed is placed in the hydroseeder (otherwise inoculant could be washed off seed), or the seed dry-applied prior to hydromulching.
- For revegetation, each seed bag delivered to the site should be sealed and clearly marked as to species, purity, percent germination and expiry date. The container should be labelled to clearly reflect the % Pure Live Seed (PLS) and kept on-site for inspection purposes.

Hydraulically applied mulches include mulches made from wood fibres, paper fibres, combination recycled wood and paper fibres and polyester and/or polypropylene fibres. Hydraulic mulches should be mixed with seed, fertilizer and additives as specified and applied at the manufacturer recommended rate.

- Avoid over-spray of slurry to roads, sidewalks, watercourses, existing vegetation, etc.
- For revegetation, adequate mulch application is required to keep seeds in place and moderate soil moisture and temperature until the seeds germinate and grow (this is especially necessary in northern climates where the short growing season may limit germination of seeds until the following spring).
- Desirable ground coverage for hydraulic mulch is 80 –100 %.

Cellulose Fibre Mulches

- Paper fibre mulch is produced from recycled newsprint, magazine, or other waste paper sources.
- Mulch is mixed in a hydroseeder and applied as a liquid slurry (either alone, or in combination with seed, fertilizer and tackifier). Hydraulic application of paper fibre is easier than for wood fibre.
- Typical application rates are 60 kg mulch/1,000 litres water, applied at 1700-2200 kg/ha in order to achieve uniform, effective coverage.
- Paper mulch can also be used to tack and bind straw mulch (at a lower rate, typically 850 kg/ha).
- Short fibre lengths and rapid decomposition (versus straw and wood fibre) can limit the longevity of erosion control effectiveness.

Hydraulically Applied Wood Fibre

- Wood fibre mulches are manufactured to provide fibres that are typically 4 – 8 mm long.
- Wood fibre products have longer fibre lengths and provide improved durability versus paper fibre.
- Although more effective than cellulose mulches, wood fibre products are more expensive;

- Hydraulic applications of wood fibre are typically done with 20 kg of mulch in 500 L of water applied at 1,500 to 2,500 kg/ha (application at rates lower than 1,500 kg/ha provides little erosion control or mulching benefit).
- Wood fibre is susceptible to wind and water movement unless tacked to the ground.
- Wood fibre may not supply sufficient bulk to adequately control erosion on steep slopes.

Hydraulically Applied Bonded Fibre Matrix (BFM)

- Bonded fibre matrix (BFM) is a thick, three-dimensional, permeable blanket-like covering that holds soil and seed in place.
- BFM typically consists of longer fibres, combined with tackifiers and binding agents. BFM is chemically-bonded, mechanically-bonded or (more typically) a combination of the two.
- Chemically-bonded BFMs require a curing or drying period following application (at least 24 hours), so ensure there is no risk of precipitation during this period.
- BFM is typically applied at rates from 3,500 to 5,000 kg/ha, or at the manufacturer's recommended rate.
- A biodegradable BFM is composed of materials that are 100% biodegradable. The binder in the BFM should also be biodegradable and should not dissolve or disperse upon re-wetting.

Tackifiers/Binders

- Tackifiers are organic or polymer agents that bond mulch fibres and soil together, increasing the erosion control effectiveness of mulching.
- Additionally, some polymers, plant mucilage and guar increase hydraulic application performance by providing lubrication.
- Typical application rates are 45 – 70 kg/ha for polymers and 90 – 140 kg/ha for guar and plant mucilage (follow manufacturer specifications).
- Cementitious binders (formulated from hydrated lime or gypsum) can be mixed with water and applied to temporary roads for dust control or with fibre mulch, seed and fertilizer for erosion control (form a permeable crust on the soil surface).
- Acrylic co-polymers mixed with water are also used for dust control.

Hydroseeding Note: Applying all the mulch with seed, fertilizer and tackifier in one hydroseeding pass can result in suspension of seed in the matrix (i.e. poor seed to soil contact). It may be desirable to follow a two or three-step method, especially on rocky sites where seeds could become suspended and desiccated.

Two Step Seeding Method (with hydraulic mulch)

- Apply seed, at the recommended rate, and half the recommended mulch (850 - 1,100 kg/ha), as a slurry. This helps assure maximum seed to soil contact.
- Apply the remaining mulch with the tackifier and fertilizer. Polymer tackifiers are applied at rates of 45 - 70 kg/ha and organic tackifiers at a rate of 90 - 135 kg/ha.

Three-Step Straw Mulch Method (for steep and critical erosion-sites)

- Apply seed hydraulically in a slurry with 600 kg/ha hydraulic mulch.
- Secondly, apply straw mulch at a rate of 2,250 kg/ha.
- Finally, apply fertilizer, tackifier and the remaining hydraulic mulch at 600 - 850 kg/ha, or as specified.

Inspection and Maintenance

- Except during freeze-up, inspect a minimum of every seven (7) days after initial application and after intense or sustained rainfall or snowmelt likely to cause erosion.
- Verify hydromulch and hydroseed applications meet specifications. Record materials used and keep all certification tags for inspection and records.
- Areas where erosion is evident should be repaired as soon as possible;
- Care should be exercised to minimize the damage to protected areas while making repairs.
- Where seeds fail to germinate, or they germinate and die, the area should be reseeded, fertilized and mulched within the planting season, using not less than half the original application rates;
- For temporary applications, maintain an unbroken ground cover throughout the period of construction that the soils are not being reworked.
- For erosion control (with the exception of rock, wood and bark mulches), the effectiveness of the mulch cover should last until vegetation is established. Inspection should assess the integrity of the mulch based on the quality and diversity of vegetation being established.

BMP 15	ROLLED EROSION CONTROL PRODUCTS	Erosion Control
---------------	--	------------------------

Note: More detailed information on rolled erosion control product development, testing, selection and installation is provided by the Erosion Control Technology Council (ECTC, www.ectc.org) and in manufacturer specifications and design software.

Description and Purpose

Erosion control blankets are machine-produced mats of organic, biodegradable mulch such as straw, curled wood fibre (excelsior), coconut fibre or a combination thereof, evenly distributed on or between photodegradable polypropylene or biodegradable fibre netting. Synthetic erosion control blankets are composed of ultraviolet stabilized synthetic fibres. Nettings and mulch material are stitched to ensure integrity and blankets are supplied in rolls for ease of handling and installation.

- **Due to relatively high cost; typically used during permanent stabilization**
- **Also effective for temporary erosion control on steep slopes**

The longevity and strength of RECPs is determined by their structure and the susceptibility of the materials to biological and photo-degradation. RECPs can be grouped into three categories:

Erosion control blankets (ECBs): Temporary, degradable RECPs composed of processed natural or polymer fibres mechanically, structurally or chemically bound together to form a continuous matrix.

Turf reinforcement mats (TRMs) and composite turf reinforcement mats (C-TRMs): Long-term non-degradable RECPs composed of UV-stabilized, non-degradable synthetic fibres, nettings and/or filaments processed into three dimensional reinforcement matrices designed for permanent and critical hydraulic applications where design discharges exert velocities and shear stresses that exceed the limits of mature, natural vegetation. TRMs provide sufficient thickness, strength and void space to permit soil filing and/or retention and development of vegetation within the matrix.

Applications and Advantages

- Several categories and types of RECPs have been developed for a variety of applications. Many RECPs have undergone rigorous product testing and manufacturers/suppliers can provide good product and application information (and, in some cases; selection software). Visit www.ectc.org and consult with your RECP supplier.
- Can be a temporary or permanent measure (depending on the RECP selected).
- Provide immediate protection of erodible soils on cut/fill slopes at 3H:1V or steeper.
- Protection of exposed soils in ditches and channels (with water velocities of 1 - 2 m/sec) by providing additional shear resistance in conjunction with well-established vegetation cover (TRMs/C-TRMs).
- Useful for providing medium-term erosion protection when soils are exposed outside of a suitable growth window for vegetation establishment.
- Suitable for disturbed slopes adjacent to water bodies or environmentally sensitive areas Note: for these areas, selection of wildlife friendly products with open, biodegradable netting is important.

Limitations

- RECPs are expensive to purchase and install. High cost typically limits the use of RECPs to areas of concentrated channel flow and steep slopes. Proper RECP selection and installation is critical and requires experienced designers and contractors.
- Vegetation provides ultimate erosion control. To avoid creating unfavourable conditions for seed germination and plant growth, the designer should always assess the effectiveness of the RECP based on installation timing, site soils, aspect and slope.
- Commonly, failure to properly install the RECP (entrenchment, stapling) or provide consistent RECP:soil contact (requires proper site preparation) can result in erosion under the product.
- Temporary blankets may require removal before implementation of permanent measures.
- Not generally suitable for excessively rocky sites or in areas where final vegetation will be mowed (use of biodegradable netting helps address the mowing issue).

Installation

Note: For general guidance only. Always consult RECP manufacturers and a professional specializing in erosion & sediment control to ensure appropriate RECP selection, installation, inspection and maintenance.

Follow the manufacturer's installation specifications. If not available, the following general installation methods may be used.

RECP (Erosion Control Blanket) Installation on Hill Slopes

- 1) Ensure the slope is properly prepared before installing the blanket. The slope should be fine-graded to a smooth profile and relatively free of weeds, clods, stones, debris, rills and crusting. Fill any voids and make sure that the slope is lightly compacted.
- 2) Seed the area with a seed rate and mix suitable for the area and site-specific soil conditions.
- 3) At the top of the slope, dig an anchor trench 150 mm deep by 150 mm wide. Ideally, set the anchor trench at least 1 m back from the crest of the slope (this will help prevent water from flowing under the blanket and causing erosion). Install the end of the blanket in the trench, providing 750 mm of excess blanket extended upslope of the trench. Staple at 300 mm centres along the width of the trench.
- 4) Backfill the anchor trench and compact the soil. Place seed over the compacted soil. Cover the compacted soil with the remaining 300 mm of the terminal end of the blanket. Staple or stake the terminal end down slope of the anchor trench on 300 mm centres.

RECP Anchoring: U-shaped wire staples, metal geotextile stake pins, or triangular wooden stakes can be used to anchor mats and blankets to the ground surface. Wire staples should be made of minimum 11 gauge steel wire and should be U shaped with 200 mm legs and a 25 mm crown. Wire staples and metal stakes should be driven flush to the soil surface.

- 5) Starting at the crest of the slope, "walk" the blanket down the slope (unrolling of heavy rolls can be controlled using temporary stakes). Excess slack should be pulled out of the blanket every 6 – 7 m, taking care not to overstretch the blanket. Secure the blanket using staple patterns and staple types/sizes as recommended by the manufacturer. Follow the manufacturer's recommended

overlap when rolling out adjacent sections of blanket. Secure the overlaps with staples at recommended intervals.

- 6) If the blanket needs to be spliced in the middle of a slope, ensure the blanket is "shingled" with the up-slope blanket overlapping the down-slope blanket. There should be 100 mm of overlap in a splice. Use a staple check slot to secure the overlap: Place a row of staples 100 mm on center and then placing a second, staggered row of staples 100 mm on center.
- 7) The blanket should extend at least 0.6 m beyond the toe of the slope. Secure the blanket with staples or stakes 300 mm on centre.

Installation of Turf Reinforcement Mats (TRMs/C-TRMs) in Channels

- 1) Ensure the channel is properly prepared before installing the TRM. The channel should be fine-graded to a smooth profile and relatively free from all weeds, clods, stones, debris, rills and crusting. Fill any voids and make sure that the channel is lightly compacted.
- 2) Seed the area with a seed mix and rate suitable for the area and site-specific soil conditions. If mat installation is delayed, the contractor should rework and reseed any rutted, eroded or crusted sections of the channel prior installation.
- 3) At the top of the channel, dig an anchor trench, 150 mm deep by 150 mm wide, perpendicular to the flow line. Install the end of the mat in the trench, providing 300 mm of excess mat extending upstream of the trench. Staple the mat at 300 mm centres along the width of the trench.
- 4) Backfill the anchor trench and compact the soil. Place seed over the compacted soil. Cover the compacted soil with the remaining 300 mm of the terminal end of the blanket. Staple or stake the terminal end down slope of the anchor trench on 300 mm centres.
- 5) Unroll the mat in the direction of water flow, starting with the mat in the channel bottom. Minimize the number of seams in the channel bottom and avoid seams in the channel centre or areas that may receive concentrated run-off. Install adjoining mats away from the centre of the channel bottom using overlaps as recommended by the manufacturer. Staple the overlap seams as specified for the product.
- 6) Staple or trench check slots should be installed perpendicular to the flow direction every 7.5 m of channel. Check slots force water that is flowing under the mat back to the surface. A staple check slot consists of a double row of staples or stakes on 100 mm centres. The rows should be staggered and placed 100 mm apart. An alternative is to excavate a check slot the same dimensions as the end trench. Secure the mat in the upstream side of the check slot with staples or stakes on 300 mm centres. Flip the mat on the upstream edge. Back fill the check slot as shown and compact the soil.
- 7) Continue to roll the mat along the channel bottom and side slopes in the direction of the water flow. As the mat is installed from the channel bottom up the channel sides, use a shingle type installation (with the up-slope mat overlapping the lower mat 100 mm, or as specified by the manufacturer. Mats should be spliced using a check slot, with the upstream mat overlapping the downstream at least 100 mm.
- 8) At the terminal end of the channel, secure the mat in a with a 300 mm deep by 150 mm compacted anchor trench.
- 9) Bury the edges of the matting in 100 mm deep by 100 mm wide longitudinal anchor trenches, extending the mat at least 75 mm above the crest of the channel side slopes;
- 10) Some TRMs require filling with soil: In these cases, seed the matting and the entire disturbed area after mat installation, but prior to filling the mat with soil.

Inspection and Maintenance

- Prior to establishment of vigorous vegetation cover, inspect RECP installations a minimum of every seven days and following intense or prolonged rainfall or snowmelt likely to cause erosion.
- Ensure RECPs have good contact with the soil and look for any erosion, undermining or blanket separation. Ensure that check slots and joints are secure and that staples are flush with the ground. Repair any damage immediately and reseed as necessary.
- A dressing of fertilizer may be required to improve vegetation establishment a year after RECP installation.

Construction Details

Refer to figures:

Typical Installation Detail for RECPs on Slopes

Typical Installation Detail for RECPs in Channels

MATS / BLANKETS SHOULD BE INSTALLED VERTICALLY DOWNSLOPE.

ISOMETRIC VIEW

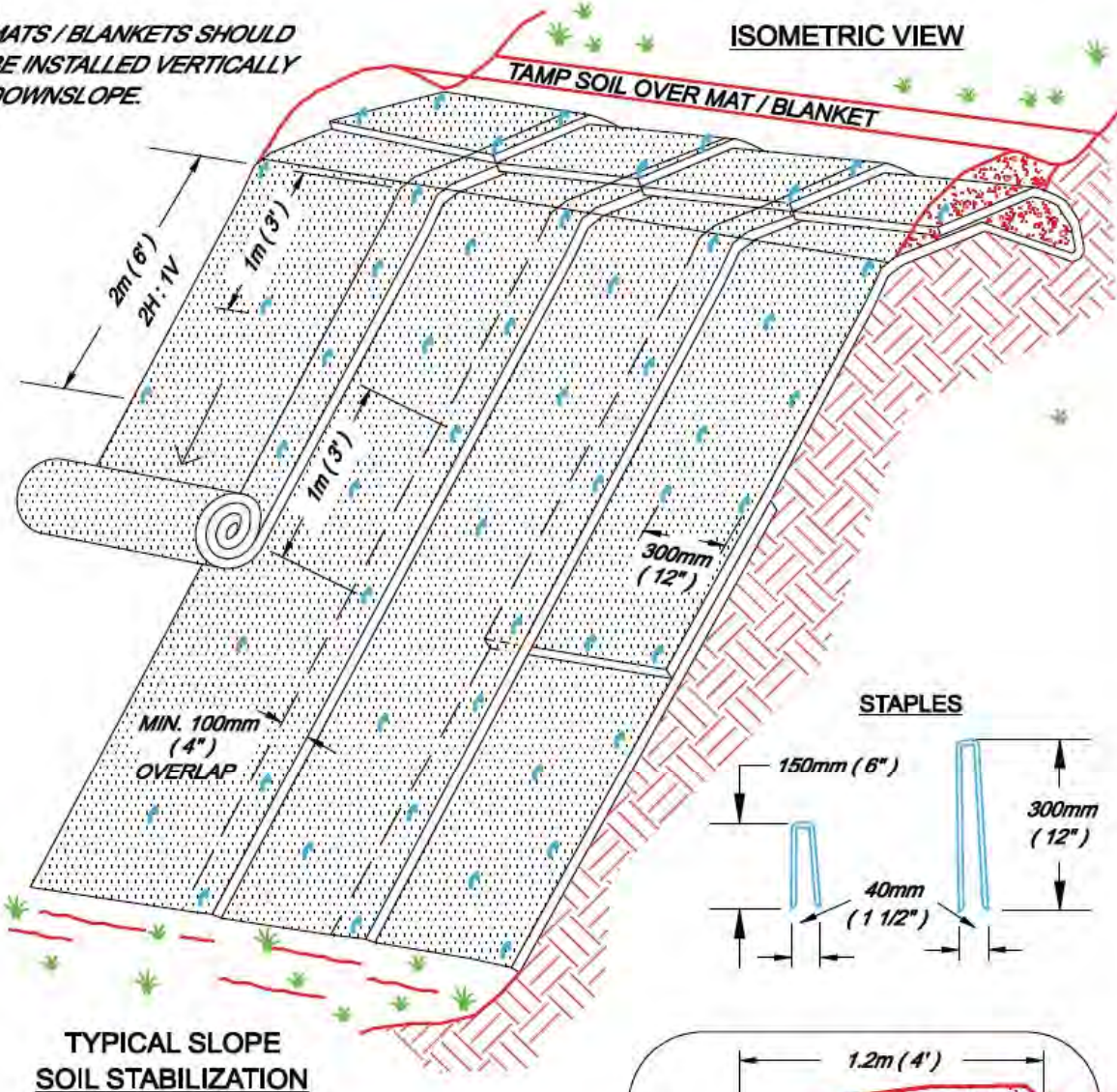

STAPLES

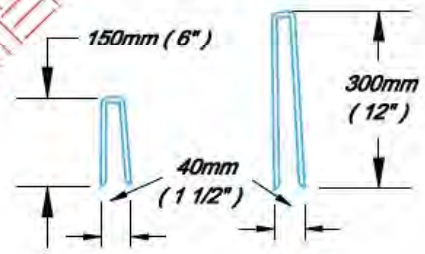

TYPICAL SLOPE SOIL STABILIZATION

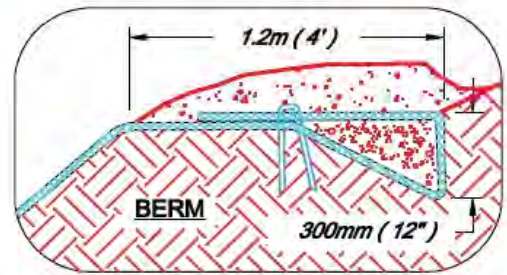

NOTES:

1. SLOPE SURFACE SHALL BE FREE OF ROCKS, CLODS, STICKS AND GRASS. MATS / BLANKETS SHALL HAVE GOOD SOIL CONTACT.
2. APPLY PERMANENT SEEDING BEFORE PLACING BLANKETS.
3. LAY BLANKETS LOOSELY AND STAKE OR STAPLE TO MAINTAIN DIRECT CONTACT WITH THE SOIL. DO NOT STRETCH.

NOT TO SCALE

Erosion Blankets & Turf Reinforcement Mats: Slope Installation



Erosion & Sediment Control Guidelines 2011

Source: Salix Applied Earthcare - Erosion Draw 5.0
 © 1994 JOHN McCULLAH FILE: blnktslp.dgn

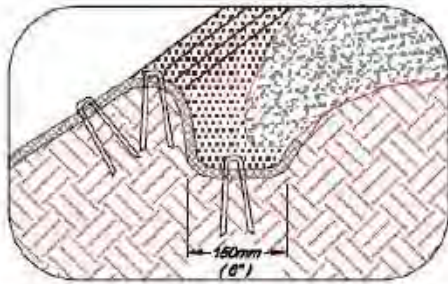

LONGITUDINAL ANCHOR TRENCH

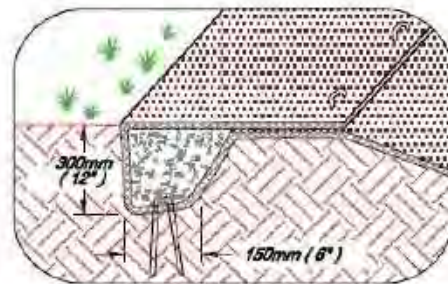

TERMINAL SLOPE AND CHANNEL ANCHOR TRENCH

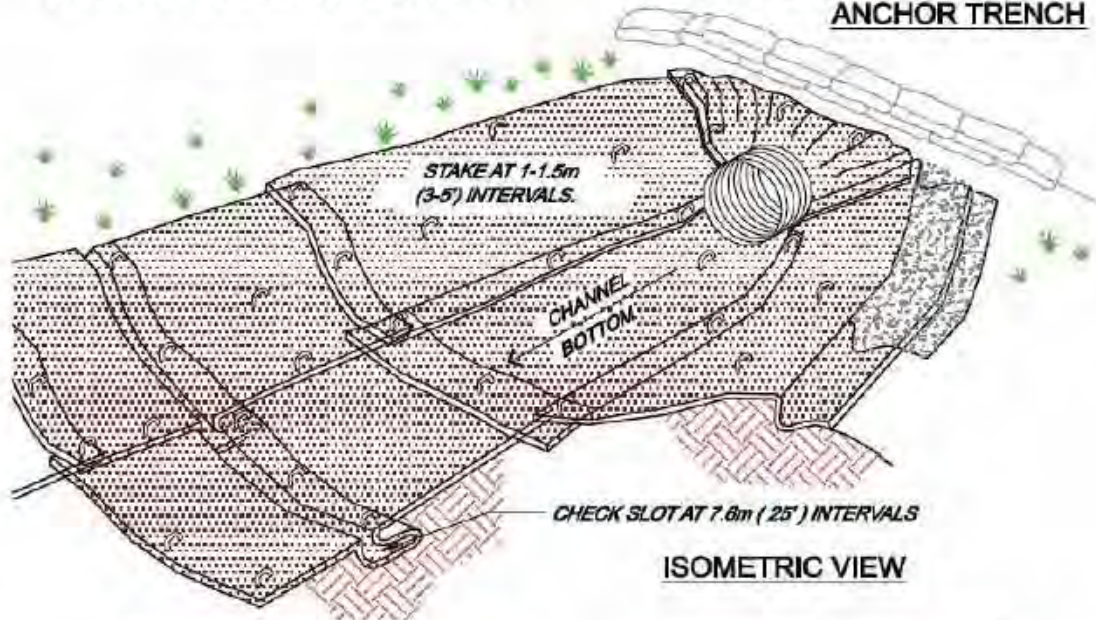

ISOMETRIC VIEW

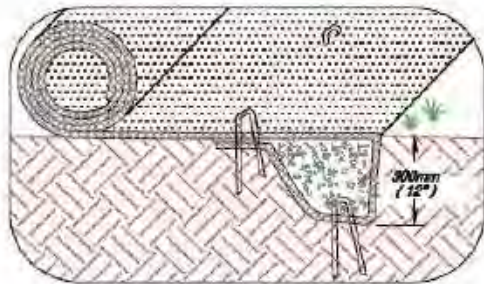

INITIAL CHANNEL ANCHOR TRENCH

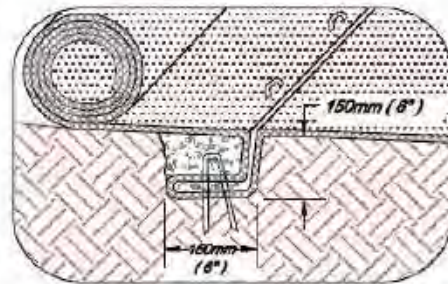

INTERMITTENT CHECK SLOT

NOTES:

1. CHECK SLOTS TO BE CONSTRUCTED PER MANUFACTURER'S SPECIFICATIONS.
2. STAKING OR STAPLING LAYOUT PER MANUFACTURER'S SPECIFICATIONS.

Erosion Blankets & Turf Reinforcement Mats: Channel Installation



BMP 16	COMPOST BLANKETS	Erosion Control
---------------	-------------------------	------------------------

Description and Purpose

Compost is produced by the controlled biological decomposition of organic materials such as agricultural, forestry, food, industrial and garden and leaf residuals. Effective composting requires a high-temperature, rapid decomposition (thermophilic) phase (which sanitizes the product) and a lower-temperature stabilization phase. The thermophilic phase should be able to reduce pathogens to acceptable levels, as well as destroy noxious weed seeds/propagules. Compost provides a good source of slow-release nutrients and enhances soil biological activity (improves plant growth and vigour).

- Typically used for permanent erosion control systems
- Can be an effective temporary erosion control practice for steep slopes

Compost, applied as a blanket to an exposed slope, can significantly reduce raindrop erosion, as well as sheet, rill and gully erosion. Compost can also remove contaminants such as TSS, nutrients and metals from stormwater run-off. In many cases, compost blankets are more effective at promoting vegetation establishment, controlling erosion and suppressing weeds than RECPs or Hydroseeding. Compost blankets can be applied by hand on small areas, but are generally applied using a pneumatic blower truck.

Note: Compost has traditionally been used as a soil amendment, applied as a finely screened, stabilized product. Application for erosion & sediment control, however, typically requires compost with a coarse, woody fraction (improves filtration rate and structural integrity).

A Compost blanket has good compost:soil contact, reducing the potential for water erosion under the blanket. This problem can further be reduced by keying the compost blanket into the crest of the slope and installing a compost berm or sock (see BMP 22, Compost Berms and Filter Socks) along the slope crest.

Note: Compost Quality: All compost **sold** in Canada should comply with the requirements of the Federal *Fertilizers Act and Regulations*. Compost **applied** in compost blankets, compost berms and compost filter socks meets Category A quality in accordance with all criteria identified in the Canadian Council of Ministers of the Environment (CCME) document *Guidelines for Compost Quality* (October 2005, and as amended from time to time). The CCME document can be purchased online at www.ccme.ca/publications.

Applications and Advantages

- Compost blankets can be installed on any soil surface: rocky, frozen, flat, or steep. A specified seed mix is usually incorporated with compost during application.
- Compost blankets can be applied to slopes 2H:1V or gentler, but can be combined with additional practices such as compost berms or compost socks to treat slopes as steep as 1H:1V (stream banks, road embankments, exposed construction site slopes). Compost blankets should be extended 1 – 1.5 m over the crest of the treated slope.
- Compost blankets should not be applied in areas subjected to concentrated run-off.

- Compost is organic, biodegradable and renewable.
- Compost retains a large volume of water and can promote infiltration and vegetation establishment (reduced run-off and erosion).
- Erosion control composts have a well-graded mixture of particle sizes: Compost blankets form a strong, three-dimensional protective soil cover and compost berms and socks are effective at filtering out suspended solids from sediment-laden run-off, allowing clean water to pass (unlike other practices such as silt fence which can quickly become plugged with sediment and act as water dams).
- Compost provides a matrix rich in beneficial micro-organisms and organic matter, promoting the vigorous establishment of vegetation, as well as biodegradation of stormwater contaminants.
- Numerous studies have shown the low or zero leaching of nutrients, metals and salts from compost.
- Compost can suppress noxious weeds, allowing desirable vegetation to better compete for nutrients and moisture.

Limitations

- In some areas, economical supply of suitable compost for erosion control may be limited.
- The supply of compost from municipal garden waste and leaf waste composting is limited, but continuing to grow. Compost supply from the forestry sector is reasonable.

Implementation

- Specified compost depth is dependant on slope steepness and annual precipitation, but is typically 50 – 100 mm (50 mm for 4H:1V slopes to 100 mm for 2H:1V slopes, with additional control measures required for slopes steeper than 2H:1V).
- When a pneumatic blower truck is utilized, a specified seed mix and rate can be incorporated with the application.
- Compost quality and screen size is important. A well-graded mixture of coarse and fine particles is desirable for ESC applications.
- In order to prevent water from sheeting between the compost blanket material and soil surface on a slope, a minimum 1 m wide band of blanket material should be installed on the shoulder of the slope. Alternatively, a compost berm or filter sock may be placed at the top of the slope.
- Compost blankets generally need to be installed by a specialized, certified supplier using a pneumatic blower truck and compost meeting CCME Category A requirements.
- Always ensure upstream run-off is diverted away from exposed slopes.
- Prepare the slopes by removing loose rocks, roots, clods, stumps and debris over 50 mm in diameter.
- Machine track-walk up and down slopes (if feasible) before application.
- For very steep slopes, compost berms, straw wattles or compost socks should be installed at intervals (install on contour), so as to reduce effective slope length.
- To provide a stable, three-dimensional blanket, compost should consist of both large and small fragments. Finer grades (screened through 10 - 15 mm) have increased nutrient availability, promoting vegetative cover. Inclusion of coarser grades promotes infiltration and improves the structural integrity and resistance of blankets exposed to wind, rainfall and run-off. Optimal moisture

content at application is 25 – 40%. Compost outside this range can be difficult to apply and wet compost is expensive to transport.

- Compost should be free of weeds, weed seeds, pesticide residues and garbage.

Inspection and Maintenance

- Inspect compost blanket installations at least monthly and following significant rainfall or snowmelt.
- Re-apply compost to bare or eroded areas.
- Reseed areas with poor germination or vegetation establishment.



Protection of water body adjacent to a stripped area of land is enhanced with a seeded compost berm and compost blanket (promotes filtering of sediment-laden run-off and provides an erosion-resistant buffer.



Installation of a compost berm

BMP modified from the City of Calgary - Guidelines for Erosion & Sediment Control (2011 Edition) Appendix A Best Practices For Controlling Erosion and Sedimentation on Urban Construction Sites

BMP 17	STRAW/FIBRE WATTLES	Erosion Control
---------------	----------------------------	------------------------

Description and Purpose

Straw/Fibre wattles (commonly called rolls) consist of bundled straw (or other natural fibre) wrapped in photo-degradable open-weave plastic netting and staked (using wood stakes or live willow stakes) into the soil along slope contours as a grade break. Wattles can also retain sediment and seed washed downslope and retain moisture, promoting the growth of vegetation. Wattles are typically 200 mm diameter and 8-9 m long. Mobile units that can produce continuous lengths of fibre wattle have recently been developed.

- **Temporary or permanent measure**
- **Use from stripping and grading to final site stabilization**
- **Slopes, stockpiles (seeding), borrow areas, landscaping**

Applications and Advantages

- Useful for long, exposed slopes (reduce slope length, reduce rilling and decrease run-off velocity).
- Relatively low-cost option for controlling sheet and rill erosion on slopes.
- Used as a grade break, where a gentle slope changes to a steeper slope.
- Can be used in combination with live-staking (bioengineering application).
- Plastic netting will eventually photo-degrade, eliminating the need for retrieval and disposal of materials after the straw has broken down.
- Straw becomes incorporated into the soil with time, adding organic material to the soil and retaining moisture for vegetation.

Limitations

- Only suitable as a temporary (one to two year life) erosion control practice (long term erosion control requires establishment of sustainable vegetation cover).
- Limited to sheet-flow conditions. Not suitable in areas subjected to concentrated run-off.
- May be labour intensive to install and maintain.
- Undermining and failure can result from poor installation and maintenance (failure to properly trench, stake and overlap joints).

Implementation

- Prepare the slope by removing large rocks and debris.
- Repair any rills and gullies on the slope and ensure upstream run-off is diverted away from exposed slopes.
- Starting at the toe of the slope, excavate small trenches across the slope. Trenches should be deep and wide enough to accommodate half the thickness of the roll (typically 0.15 m x 0.15 m). It is critical that rolls are installed perpendicular to water movement, parallel to the slope contour.
- Space trenches at contour intervals of 1 - 8 m, depending on steepness of slope. The steeper the slope, the closer the trench spacing.

- Place fibre rolls into the trench, ensuring continuous contact between the roll and soil.
- Overlap the ends of rolls at least 0.15 m by excavating some additional trench at overlaps.
- Prior to placing wood stakes or live willow stakes, use a metal bar to drive pilot holes through the roll and into the soil. Stake spacing should not exceed 1.2 m. Ensure overlaps are well staked. Drive stakes through prepared holes into the soil. Leave only 25 - 50 mm of stake exposed above the roll.
- Place and compact excavated soil on the upslope side of the roll and seed with a specified seed mix.

Inspection and Maintenance

- Except during freeze-up, inspect straw rolls and slopes at least weekly and promptly after significant rainfall or snowmelt.
- Ensure all sections of rolls are in good contact with the soil.
- Repair any rills or undermining promptly. Additional run-off or erosion control is required for areas subject to rilling.
- The straw or organic fibre in the rolls will decompose and netting will photo-degrade.

Construction Details

Refer to figure:

Installation Detail for Straw/Fibre Rolls or Compost Socks



Straw wattles provide an excellent type of ditch check in small ditches conveying small volumes of run-off.

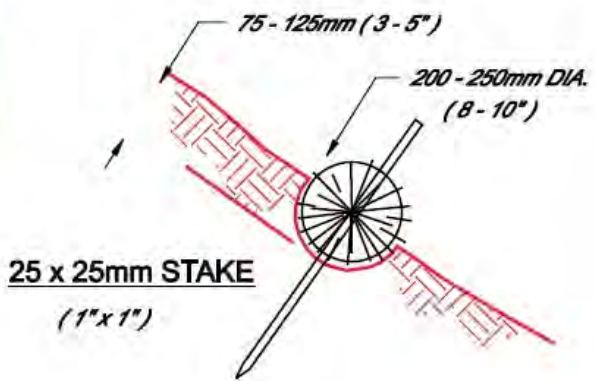
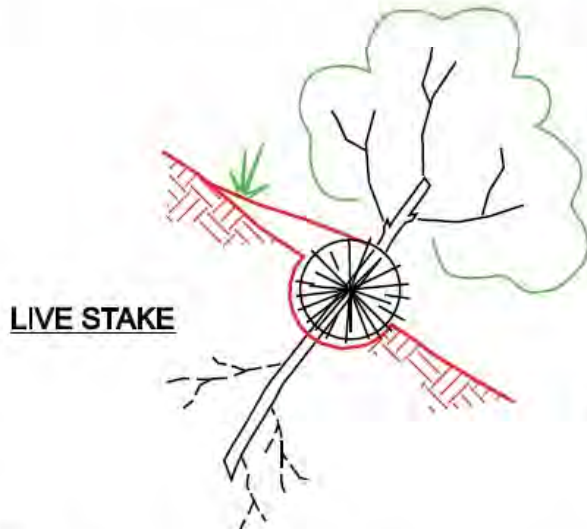
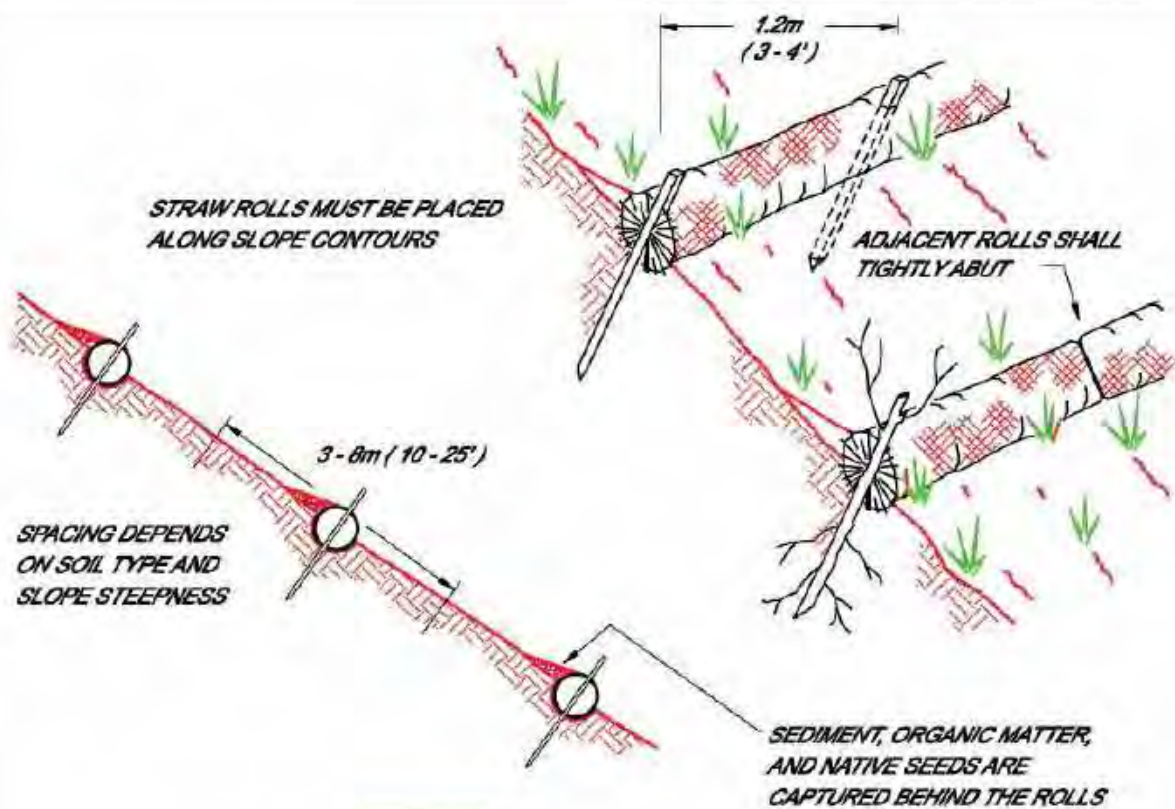

NOTE:

1. STRAW ROLL INSTALLATION REQUIRES THE PLACEMENT AND SECURE STAKING OF THE ROLL IN A TRENCH, 75-125mm (3-5") DEEP, DUG ON CONTOUR. RUNOFF MUST NOT BE ALLOWED TO RUN UNDER OR AROUND ROLL.

NOT TO SCALE

Straw / Curlex / Coir Rolls (Fibre Rolls)



Erosion & Sediment Control Guidelines 2011

Source: Salix Applied Earthcare - Erosion Draw 5.0
 © 1996 JOHN McCULLAH FILE: strwroll.dgn

BMP 18	RIPRAP	Erosion Control
---------------	---------------	------------------------

Description and Purpose

Riprap (large, loosely placed cobbles/boulders) is a versatile, highly erosion-resistant material. Riprap armouring involves placing a layer of suitable rock to protect the soil surface from erosive forces and/or improve stability of soil slopes that are subject to seepage or have poor soil structure.

- **Temporary or permanent measure**
- **Channels and steep slopes**

Note: "Pre-cast riprap" is a term commonly applied to grid pavers, articulated concrete mats, concrete armour units, and interlocking concrete blocks. These modular concrete units are used to armour slopes and stream banks, while providing pockets for the establishment of vegetation. The specific design and installation should follow manufacturer's instructions.

Applications and Advantages

- For cut and fill slopes subject to seepage, weathering and/or significant erosion, particularly where conditions prohibit establishment of vegetation.
- On channel side slopes and bottoms (flow velocities of 2 – 5 m/sec: See BMP 8 Riprap-Lined Channels).
- As an energy dissipater (see BMP 10 Energy Dissipaters) and on steep sections of bridge abutments.
- For shorelines subject to wave action.

Note: Should be used in conjunction with a non-woven geotextile or gravel filter underlay.

- Riprap is flexible (can adjust to changes resulting from settling or erosion beneath the stone).
- The rough surface of riprap provides good energy dissipation in flowing water.
- Durable, low maintenance and easy to install and repair.

Limitations

- Expensive, subject to availability and requires heavy equipment for transportation and placement.
- For equivalent protection to a gabion mattress, open riprap typically needs to be placed at 2 – 3 times the thickness.

Implementation

- For areas that will require riprap, try to schedule riprap placement to immediately follow disturbance and grading (i.e. for inlet or outlet protection, riprap should ideally be placed before run-off causes erosion).
- Riprap is classed as either graded or uniform: Graded riprap includes a wide mixture of stone sizes, whereas uniform riprap consists of stones nearly all the same size. Graded riprap is generally preferable because it is cheaper, easier to install and forms a dense, flexible cover.

- Stone used for riprap should be hard, durable, erosion resistant field or quarry materials (avoid sedimentary rock). The material should be angular and not subject to breaking down when exposed to water or weathering. Specific gravity should be at least 2.5.

Filter Blankets

A filter blanket is a layer of material placed between the riprap and the underlying soil to prevent soil movement into or through the riprap. A suitable filter may consist of well-graded gravel or gravel-sand layer or a suitable non-woven geotextile filter fabric. The design of gravel filter blankets is based on the ratio of particle size in the overlying filter material to that of the base material in accordance with the following design relationship:

$$\begin{array}{ccc}
 \frac{D_{15} \text{ Filter}}{D_{85} \text{ Base}} \leq 5 & \text{and} & 5 < \frac{D_{15} \text{ Filter}}{D_{50} \text{ Base}} \leq 40 & \text{and} & \frac{D_{50} \text{ Filter}}{D_{50} \text{ Base}} \leq 40
 \end{array}$$

Subgrade Preparation

- Prepare the subgrade for the riprap and filter (underlay) to the required elevations and grades shown on the drawings.
- Compact any fill required in the subgrade to a density approximating that of the undisturbed material.
- Excavate the subgrade sufficiently deep so the finished grade of the riprap will be at the elevation of the surrounding area.
- Channels should be excavated sufficiently to allow placement of the riprap in a manner such that the finished inside dimensions and grade of the riprap meet design specifications.

Sand And Gravel Filter Blankets

- Install the filter blanket immediately following subgrade preparation.
- For a gravel filter layer, spread the gravel in a uniform layer to the specified depth.
- Where more than one layer of filter material is used, spread the layers with minimal mixing.

Non-Woven Geotextile Filter

- Place the geotextile on the prepared subgrade.
- Overlap the edges of the fabric by at least 600 mm and space anchor pins every 1 m along the overlap.
- Bury the upper and lower ends of the cloth a minimum of 300 mm.
- Carefully place riprap (by machine and hand) in order to avoid damaging the cloth. If damage occurs, remove the riprap and repair by placing another piece of filter fabric over the damaged area, with an overlap of at least 300 mm.
- For placement of large riprap, a 100 mm thick layer of sand or gravel is recommended to protect the cloth.

Stone Placement

- Riprap should consist of a graded mixture such that 50 % of the mixture by weight should be larger than the D₅₀ size selected by the designer. The largest rock size should be no more than 1-1/2 times the D₅₀ size while the smallest size should be approximately 25 mm.

- The minimum thickness of the rip-rap layer should be 1-1/2 times the maximum stone diameter, but not less than 300 mm.
- Riprap should be installed in one operation, immediately after the filter placement.
- Install riprap so that it forms a dense mass of well-graded stone with a minimum of voids.
- The desired distribution of stones throughout the placement may be obtained by selective loading at the quarry and controlled dumping during final placement.
- Be careful not to damage or dislodge the underlying base or filter when placing riprap.
- The toe of the riprap should be keyed into a stable foundation.
- Hand placement may be necessary to help achieve proper distribution of stone sizes to produce a relatively smooth, uniform surface.
- The finished grade of the riprap should blend with the surrounding area.

Inspection and Maintenance

Riprap should be inspected periodically for scour or dislodged stones.

Control weed and brush growth as required.

Little maintenance is generally required.

Construction Details

Refer to figure:

Riprap Slope Protection

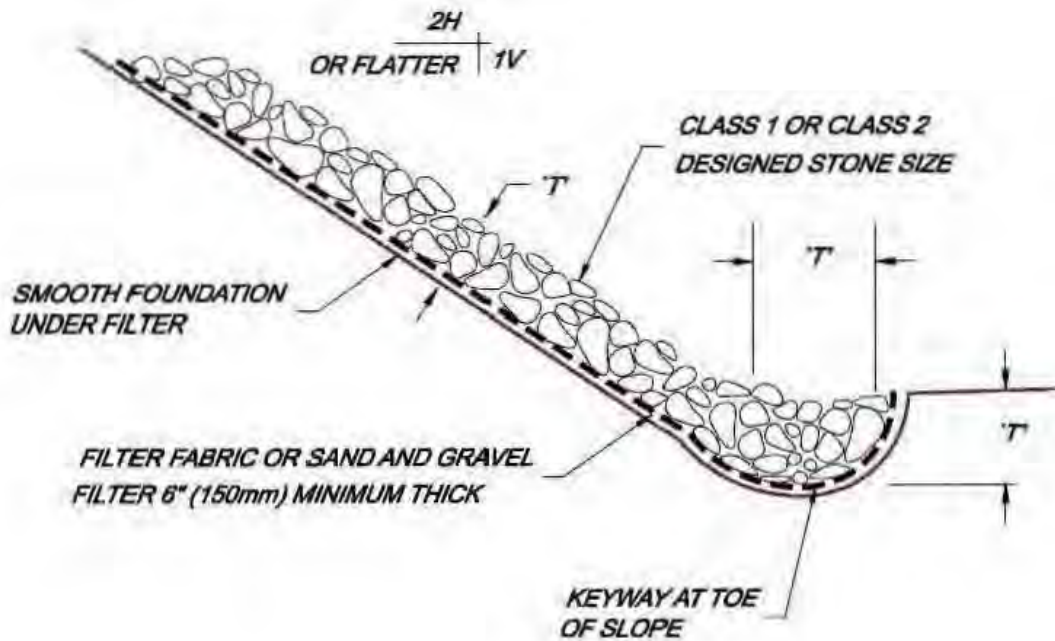

TYPICAL SECTION

NOTE:

*'T' = THICKNESS: Thickness shall be determined by the Engineer.
Minimum thickness shall be 1.5x the maximum diameter, never less than 150mm (6").*

*The toe of the riprap must be keyed into a stable foundation.
Hand placement may be necessary to help achieve proper
distribution of stone sizes to produce a relatively smooth, uniform surface.
The finished grade of the riprap must blend with the surrounding area.*

INSPECTION & MAINTENANCE:

*Riprap should be inspected periodically for scour or dislodged stones.
Control weed and brush growth as required.
Little maintenance is generally required.*

Riprap Protection



Erosion & Sediment Control Guidelines 2011

Source: Salix Applied Earthcare - Erosion Draw 5.0
© 1994 JOHN McCULLAH FILE: riprap.dgn

BMP 19	DUST CONTROL	Sediment Control
---------------	---------------------	-------------------------

Description and Purpose

Soil erosion by wind can be a significant problem. Dust control prevents wind transport of dust from disturbed soil surfaces onto roadways, drainage ways and into watercourses.

- **All stages of construction where there is exposed soil**
- **Especially haul roads, stripped areas, and Stockpiles**

Applications and Advantages

- Dust control measures should be applied to large areas of exposed soil, especially sub soils that are disturbed and prone to drying out.
- Dust control measures should also be applied to stockpiles, haul roads and other disturbed areas exposed to wind.
- The timely implementation and frequent inspection and maintenance of practices used to control dust can significantly improve the health and safety of construction workers and the general public.

Limitations

- Dust control measures such as water application and chemical dust suppressants will need to be frequently inspected and the measures reapplied.

Implementation

Dust can be controlled by:

- Clearing vegetation only from areas that will be worked right away.
- Vegetating or applying mulch to areas that won't receive vehicle traffic.
- Constructing wind breaks or wind screens.
- Spraying the site with water until the surface is wet. Care should be taken that this does not lead to tracking of mud onto nearby streets.
- Spraying exposed soil areas with a dust palliative. Used oil is prohibited as a dust suppressant.
- Stopping work in serious adverse wind conditions.
- Using and maintaining internal haul roads.
- To protect adjacent roads and property owners:
- Lower speed limits to decrease dust stirred up from unpaved roads and lots.
- Add surface gravel to reduce the source of dust emission. The amount of fine particles should be limited to 10 to 20%.
- Use geotextiles to increase the strength of new roads or roads undergoing reconstruction.
- Encourage use of alternate paved routes if possible.
- Encourage use of internal haul roads and maintain as required.

- Restrict use by tracked vehicles and heavy trucks to prevent damage to the road surface and base.
- Apply chemical dust suppressants.
- Pave unpaved permanent roads.

Note: Work such as stripping and grading, or other work involving large equipment, should be stopped during extreme windy conditions where excessive dust is being generated.

BMP 20	CONSTRUCTION DEWATERING ACTIVITIES	Sediment Control
---------------	---	-------------------------

Description and Purpose

The term dewatering encompasses various methods used to remove and discharge excess water from a construction site. The most common method is to pump water out of areas where it does not otherwise drain off (i.e. excavations, sediment basins and traps). Water pumped out of cofferdams, excavations, footings and other areas where water can accumulate may contain high concentrations of suspended solids. The solids are sometimes already suspended in the water, or construction or pumping activities can mix the solids into the water. In all cases, adequate sediment control (i.e. using diversion structures, well points, filter sump pits, sediment traps, sedimentation tanks, flocculants or coagulants) should be provided before the pumped water is discharged.

- **Disposal of trapped groundwater and surface water from ponded areas and excavations**

Suitable Applications

- Good dewatering practice should be implemented for the discharge of impounded surface water, groundwater and shallow seepage from construction excavations and depressed areas.

Limitations

- Dewatering requirements are site specific: Site conditions will dictate design and use of dewatering operations. Consultants and contractors should be familiar with dewatering best practices and may often need to apply a combination of source controls and sediment controls (treatment train) to be effective.
- Many dewatering controls only address sediment and not other contaminants such as metals and hydrocarbons. Detailed information on-site history and baseline water quality is often required before a drainage or dewatering permit is issued.
- Fine sediment is very difficult to filter or settle using conventional means. As in all cases, sediment is best controlled at the source using a combination of run-on, run-off and erosion controls. In addition to conventional filtering and settling practices, it may be necessary to use suitable flocculants or coagulants to promote settling of fine silt and clay-size material.

Implementation

Dewatering practices are site and soil specific. It is always most effective to control sediment at the source (divert clean run-on away from disturbed areas, stabilize site soils and drainage channels, collect water in well point or filter sump systems). Particularly in the case of fine suspended sediment in water, a combination of treatment options are usually required. The following provides some basic, generic information on possible collection and treatment options. Many of the best practices discussed in other sections could also be applied to provide effective dewatering.

Note: The invert of the discharge pipe should be above water level.

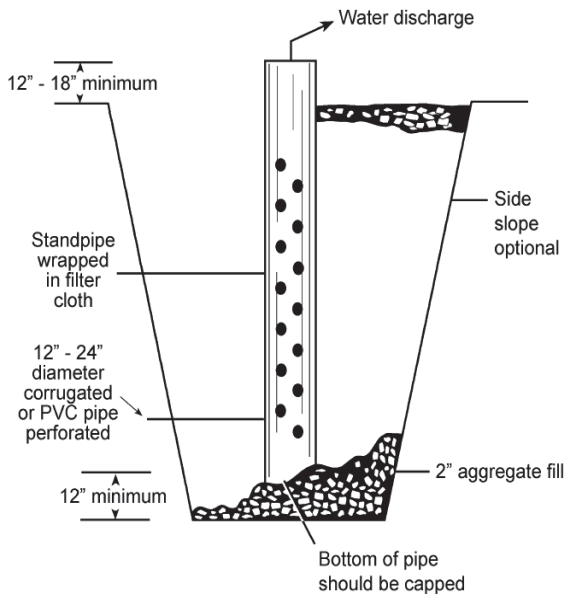

Sump Pits

- A sump pit is a temporary pit placed to collect water in an excavation, cofferdam, sediment trap or basin so as to minimize contamination of water with sediment.
- A perforated standpipe wrapped in an appropriate geotextile designed to minimize plugging is placed in the center of the pit and the excavation is backfilled with 40 – 50 mm filter gravel.
- Water that collects in the pit flows through the gravel into the standpipe and is generally pumped to a filtering or settling control for additional treatment.
- Constructing a suitable sump pit provides a simple method for collecting water in an excavation, cofferdam, sediment trap or basin. A sump pit may be used for dewatering where space is limited (common on urban construction sites). It should generally be used only for small flows and volumes.

Source: U.S. Environmental Protection Agency (EPA), 1992

Gravity Bag Filters (Dewatering Bags)

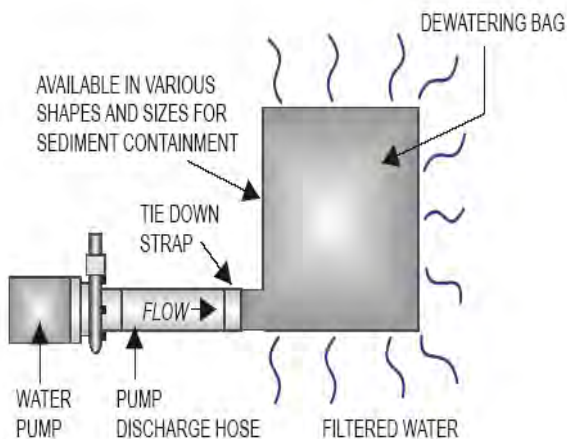

- A gravity bag filter, also referred to as a dewatering bag, is a square or rectangular bag made of non-woven geotextile fabric that can filter sand and coarse silt from sediment-laden water. Note: Dewatering bags do not remove fine silt and clay-sized material.
- Water is pumped into one side of the bag and seeps through the bottom and sides of the bag.
- A secondary barrier, such as a rock filter bed or straw/hay bale barrier, should be placed beneath and beyond the edges of the bag to capture sediments that escape the bag.
- Frequent inspection of the flow conditions, bag condition, bag capacity, and the secondary barrier is

required.

- Replace the bag when it no longer filters sediment or passes water at a reasonable rate

Weir and Clarifier Tanks

- The addition of weirs or plates to a settling tank increases retention time (prevents bypass from inlet to outlet) and, in the case of slanted plate clarifier tanks, provides a large surface area for the attachment and settling of very fine particles (often pre-treated with a coagulant).
- To achieve high levels of flow, multiple tanks can be used in parallel. If additional treatment is desired, the tanks can be placed in series or as pre-treatment for other methods.
- Suitable tank size will depend on flow volume and the residency period required.
- Periodic cleaning will be required to keep the system functional.

Pressurized Bag Filters

- A pressurized bag filter is a unit composed of single filter bags made from polyester felt material. The water filters under pressure through the unit and is discharged through a header.
- Pressurized bag filters do not remove fine clay-size material, so turbidity in the discharge water may exceed water quality requirements. Where fine clay-size material is an issue, it may be necessary to pre-treat the water with addition and mixing of a suitable dosage of flocculant or coagulant, followed by settling in a weir or clarifier tank.
- The filter bags require replacement when the pressure differential equals or exceeds the manufacturer's recommendation.

Inspection and Maintenance

- Sediment removed during the maintenance of a dewatering system may be either spread on-site and stabilized, or disposed of at a suitable disposal site.
- Sediment that is commingled with other pollutants should be disposed of in accordance with all applicable laws and regulations.
- Conduct frequent turbidity monitoring, upstream and downstream of the dewatering activity (including at the discharge point), with a calibrated, handheld turbidity meter. Implement mitigation or contingency measures if turbidity in the discharge exceeds allowable values.
- Avoid dewatering areas where fresh concrete has been placed. Ensure pH of discharge water meets regulatory requirements.



Inclined Plate Clarifier Tank commonly used for construction dewatering sediment removal.

BMP 21	SEDIMENT TRAPS AND BASINS	Sediment Control
---------------	----------------------------------	-------------------------

Description and Purpose

Sediment traps and basins are sediment containment systems designed to provide containment storage volume for sediment-laden run-off, create still conditions to promote the deposition of sediment and to discharge water at a controlled rate. The capture and temporary detention of run-off is created by excavating a pond, constructing an embankment and installing a suitable outlet. Temporary basins/traps are especially suitable for capturing and treating sediment-laden run-off from sites that are stripped and/or graded. Note: This practice should be used in combination with practices for controlling run-on/run-off and erosion.

- **All Stages of construction**

Sediment traps refer to simple containment intended to capture and treat run-off from disturbed areas of 2.0 ha or less (pond surface area is generally < 500 m²). Sediment traps vary from small excavated depressions to v-ditches and berms (created by a grader blade) to small basins with designed storage volume, settling depth and an outlet.

Sediment basins are suitable for disturbed drainage areas greater than 2.0 ha (pond area is generally > 500 m²). Due to the size and volume and potential damage that could result from failure and inherent safety considerations, sediment basins must be designed by qualified engineering consultants. Design considerations include: Sizing for required particle size removal, sediment storage and settling volume, length:width ratio and baffles.

On most construction sites, retention of all run-off (i.e. 100 % efficiency) is nearly impossible (requires large storage volume, with sufficient seepage and evaporation; permanent water retention will also make maintenance difficult). Instead, containment systems are designed to detain run-off so as to capture “design-size” sediment, while still being able to drain. Minimum storage volumes for construction site run-off are typically based on run-off from a 2 year, 24-hour design storm, and assuming 100 % run-off: this equates to approximately 25 mm depth of run-off, totaling 250 m³/ha

Note: Since sediment basins and traps must generally be designed as detention (not retention) systems, 100 % suspended sediment removal will not be possible. Therefore, it is always necessary to implement effective erosion and run-off controls (source control) in combination with sediment controls.

Suitable Applications

- Sediment traps and basins supplement erosion control by detaining sediment-laden run-off and providing settling conditions.
- Traps and basins are generally used as a temporary measure during construction.
- Depending on upstream soil texture, and if properly designed, installed and maintained, traps and basins can remove 70 to 80 % of the sediment from detained run-off. Sediment finer than the medium silt-size fraction is difficult to settle using temporary detention, so will likely pass through the structure untreated.

- The use of a skimmer device connected to an outlet improves sediment-trapping efficiency by regulating the filling and draining of a basin better than conventional methods (using perforated risers or stone).
- To decrease sediment settling time, the controlled addition and mixing of an approved chemical flocculant may be considered. Excess flocculant should not be allowed to enter a receiving water. Only products that are proven to be non-toxic to fish and aquatic invertebrates may be used.
- Traps or basins can be installed at the site perimeter, as well as intermediate points, to retain concentrated, sediment-laden run-off. Perimeter sediment containment should be installed prior to commencement of site stripping, grading and other earthwork.
- Sediment basins are used for disturbed drainage areas greater than 2.0 ha (typical design life is 12 to 18 months). Sediment basins are ideally constructed at the future location of wet or dry ponds.
- Sediment traps are used for disturbed drainage areas of 2.0 ha or less (typically used for up to one year, or until the contributing upstream area is stabilized).

Limitations

- Traps and basins are generally limited to removal of medium silt and larger particles (due to space and storage constraints). Increasing detention time may allow removal of smaller fractions.
- Where accessible, traps and basins are attractive and dangerous to children, requiring protective measures such as fencing.
- Excessive retention of stagnant water can provide mosquito breeding areas, as well as reducing storage available for subsequent storms. In addition to infiltration and evaporation, it may be necessary to conduct approved dewatering of the structure or to design more detention than retention (i.e. device or outlet for slowly draining the structure).
- Traps should not be located in live streams.
- Periodic removal of accumulated sediment is required.

Design and Construction Considerations

- Sediment traps can vary from simple excavations or low areas designed to capture run-off, V-ditches with ditch checks and wheel-compacted berms (created along contours using the blade on a grader) to traps designed similar to basins (storage volume, settling depth, length:width ratio, etc.)
- Sediment basins should be designed and constructed to provide two zones: A sediment storage zone (at least 0.3 m depth) and a sediment settling zone (at least 0.6 m depth), with a detention time of 24 to 40 hours.
- Sediment basins should have a length:width ratio of more than 6:1 (otherwise baffles, such as silt fence or rock, should be installed to prevent short-circuiting). Length:settling depth ratio should not exceed 200.
- All excavating should be conducted in a manner that minimizes/prevents erosion or water pollution.
- Construct sediment traps and basins at the construction site perimeter prior to wet season and construction activities
- Locate traps so as to maximize storage benefit from the terrain and for ease of clean-out and disposal of trapped sediment.
- This control should be installed as close to the sediment source as possible.

- Wherever possible, run-on/run-off from stabilized areas should be diverted away from the trap.
- Where practical, contributing drainage areas should be subdivided into smaller areas and multiple sedimentation traps installed.

Construction

- The use of temporary diversion berms, channels or other means of diversion may be necessary to divert run-off from disturbed areas into traps or basins.
- Clear all vegetation, roots and debris from the footprint area of the trap/basin and embankments and dispose of properly.
- Stockpile topsoil in appropriate location and stabilize against erosion.
- Construct the trap/basin by excavating, constructing embankments, or a combination of the two (as per the drawing specifications).
- The trap/basin bottom should be flat or gently sloping towards the outlet.
- Embankment slopes should not be steeper than 2H:1V and should be well-compacted
- Construct a berm using moist, clean, suitable soil free of rocks, roots and other debris. Construct the berm using multiple small lifts of soil not exceeding 200 mm in thickness and compacted to a minimum of 95% Proctor. The berm height should be a maximum of 1.5 m, with a minimum top-width of 1.5 m. Side slopes should be 3H:1V or flatter.
- Excavate the main outlet structure at the farthest possible point from inlet. The outlet should be placed on firm, smooth ground and should be backfilled to 95% SPD.
- Install proper inlet and outlet protection to protect from scour. The outlet pipe should consist of corrugated steel pipe to protect against pinching and blockage
- Construct an outlet apron on level grade and extend it a minimum of 1.5 m beyond the toe of the embankment.
- Line the spillway, spillway slopes and apron with a non-woven geotextile fabric.
- Install a well-graded stone mix with a minimum D_{50} of 250 mm (10") and maximum D_{50} of 0.35 m (14"), ensuring a minimum stone depth of 500 mm on the sides of the spillway.
- The top of the spillway should be a minimum of 0.45 m (18") below the top of the compacted berm.
- Consider using a skimmer device (rather than conventional riser or rock outlet structures). Conventional outlet structures poorly control the inflow and outflow of run-off from sediment basins. A skimmer drains a basin from the top (reduced turbidity) and in a controlled, slow manner. The Faircloth Skimmer (patented) is available from local suppliers.
- Construct an emergency spillway to convey flows not carried by the principal outlet. The emergency spillway should consist of an open channel (earth or vegetated) over native undisturbed soil (not fill). If the spillway is elevated, it should be constructed of riprap. The spillway crest should be depressed at least 0.15 m below the embankment. Ensure the spillway width is adequate for the drainage area.
- Set a stake in the trap or basin to indicate one third design depth. Sediment should be removed from the trap when it reaches this depth.
- Stabilize the berm against erosion (by seeding, mulch, tackifier, blankets, etc.) immediately following construction.

Inspection and Maintenance

- Inspect sediment traps and basins a minimum of every seven (7) days and after significant rainfall (> 12 mm rainfall within a 24 hour period) or snowmelt. Immediately repair any damage to the berm and or the outlet/spillway/apron.
- Ensure that sediment is removed when it reaches one third ($1/3^{\text{rd}}$) the design depth of the trap or pond. Sediment removed during maintenance may be incorporated into earthwork on the site or disposed of at a suitable location.
- Inspect the sediment trap or basin for area of standing water during every visit. Traps and basins that do not dewater within a few days can reduce storage volume for the next run-off event and may need to be manually dewatered.
- Once construction is complete and the drainage area is stabilized, remove the berm, grade the area to surrounding grade and immediately topsoil and vegetate/stabilize.

Construction Details

Refer to figures:

Typical Sediment Basin Construction

Sediment Basin with Baffles and Skimmer Outlet

Faircloth Sediment Basin Skimmer Outlet



Simple sediment trap, with stabilized inlet and outlet and application of an erosion control blanket to protect side slopes.

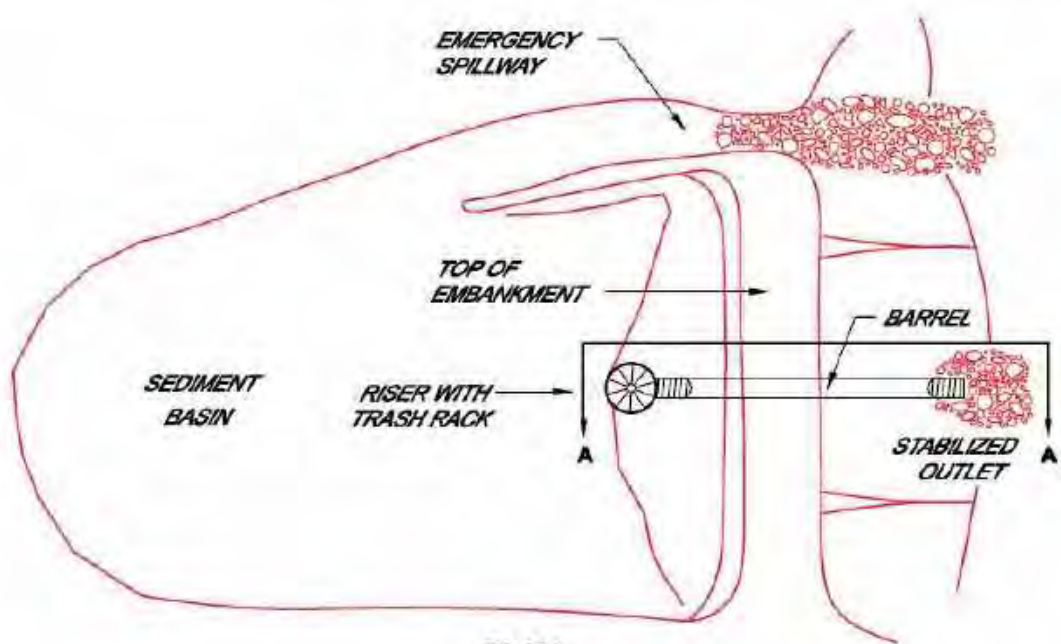

PLAN

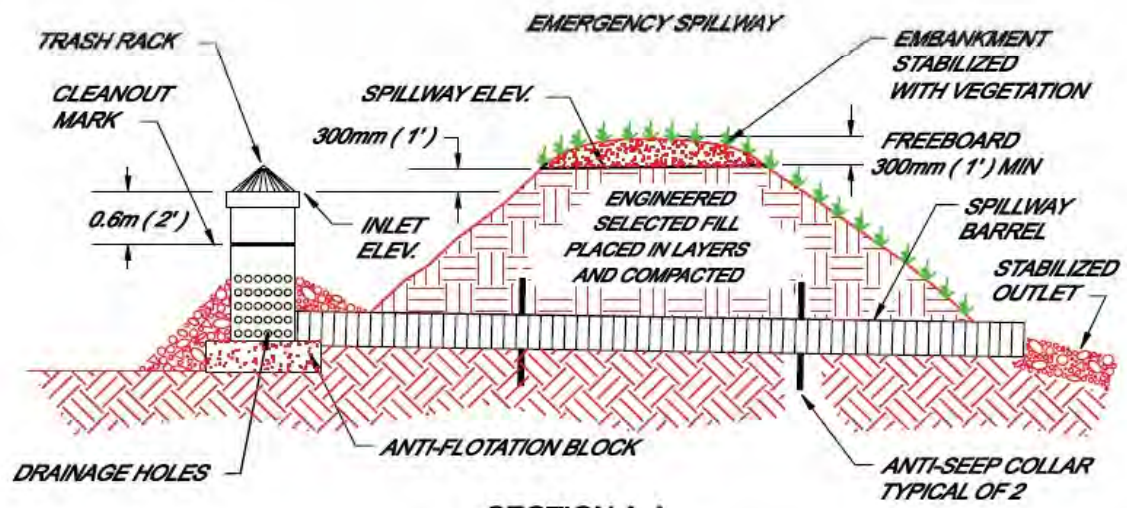

SECTION A-A

NOTES:

1. THE TEMPORARY SEDIMENT BASIN, DESIGNED BY A QUALIFIED PROFESSIONAL, IS REQUIRED FOR DISTURBED AREAS GREATER THAN 5 ACRES WITHIN A DRAINAGE AREA LESS THAN 100 ACRES.
2. THE SEDIMENT BASIN WILL BE REMOVED WITHIN 3 YEARS.

Typical Sediment Basin



Erosion & Sediment Control Guidelines 2011

Source: Salix Applied Earthcare - Erosion Draw 5.0
 © 1994 JOHN McCULLAH FILE: sedbasin.dgn

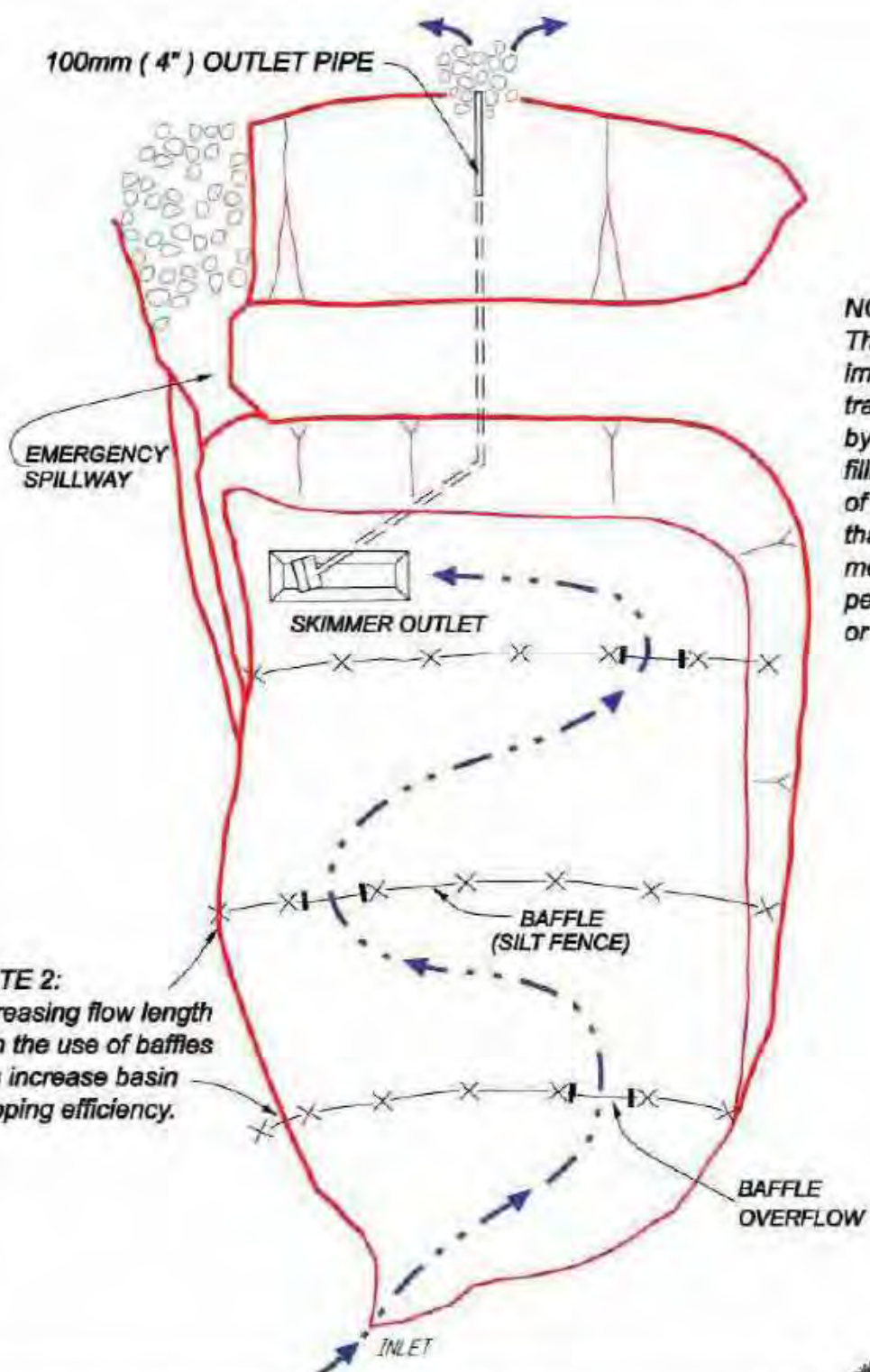

NOTE 1:
The skimmer improves sediment trapping efficiency by regulating the filling and draining of the basin better than conventional methods using perforated risers or stone.

NOTE 2:
Increasing flow length with the use of baffles can increase basin trapping efficiency.

Sediment Basin with Baffles and Skimmer Outlet



Erosion & Sediment Control Guidelines 2011

Source: Salix Applied Earthcare - Erosion Draw 5.0
 © 2001 JOHN McCULLAH FILE: sediment_basin.dgn

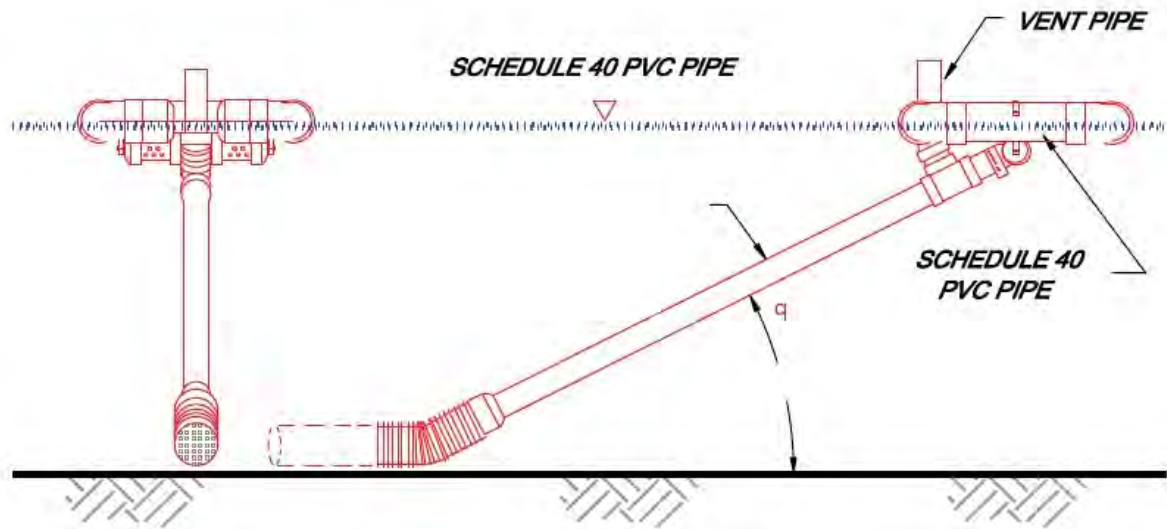

NOTE:
The most important design parameter is the control of orifice size, which can control desired dewatering time. The longer the dewatering time, the better the quality of water discharged from the sediment basin.

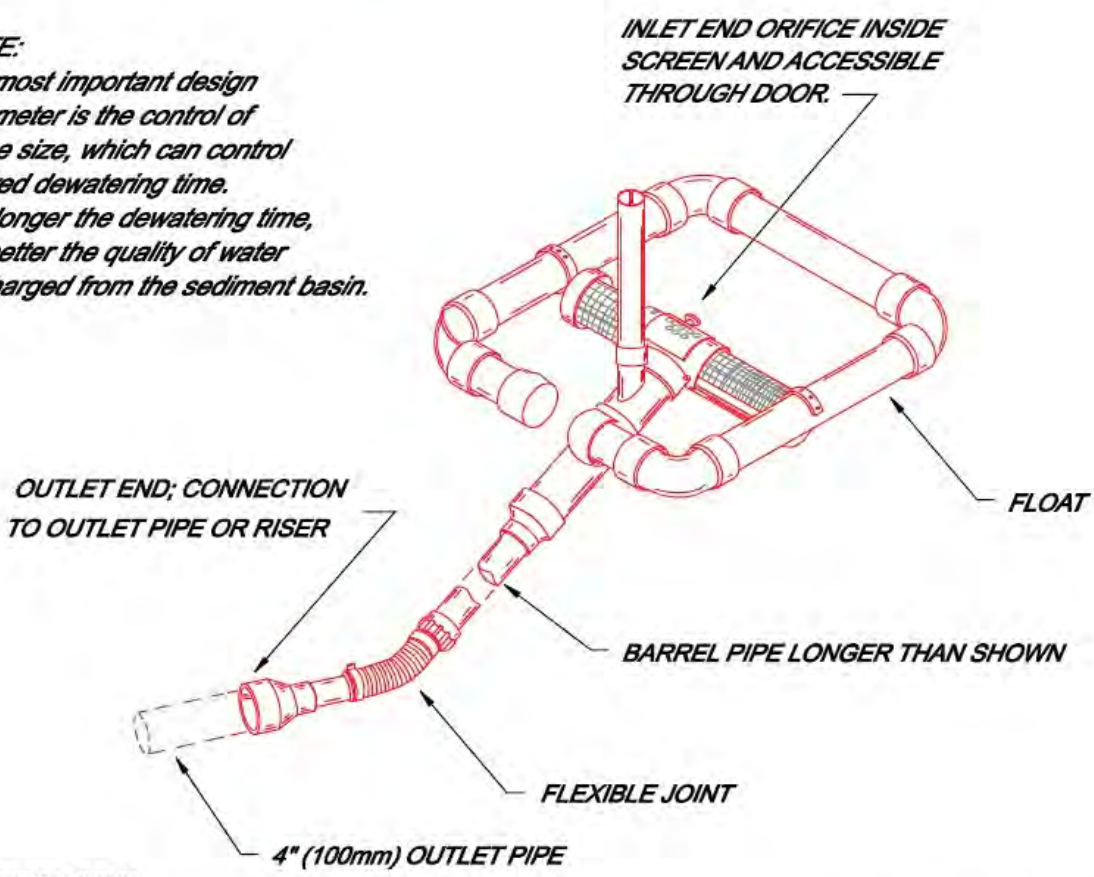

SKIMMER
 DESIGN BY: W. FAIRCLOTH
 (U.S. PATENT # 5,820,751)



Skimmer Sediment Pond Outlet

BMP 22	COMPOST BERMS AND SOCKS	Sediment Control
---------------	--------------------------------	-------------------------

Description and Purpose

A compost filter berm is a trapezoidal berm, usually constructed with a berm building machine fed by a supply of compost from a pneumatic blower truck. A compost filter sock is basically a compost filter berm contained in a mesh tube (the mesh provides added support and integrity to the structure). Filter socks vary from 200 mm to 600 mm in diameter. Both berms and socks provide an effective three-dimensional structural matrix that allows the temporary detention and filtering of construction site run-off.

- **All stages of construction**
- **Slopes, stockpiles, site perimeter**

Note: Compost Quality: All compost **sold** in Canada must comply with the requirements of the Federal *Fertilizers Act and Regulations*. Compost **applied** in compost blankets, compost berms and compost filter socks must be rated *Category A* quality in accordance with all criteria identified in the Canadian Council of Ministers of the Environment (CCME) document *Guidelines for Compost Quality* (October 2005, and as amended from time to time). The CCME document can be purchased online at www.ccme.ca/publications.

Applications and Advantages

- Vegetated berms/socks: A suitable seed mix can be incorporated into berms and socks during construction. Vegetation roots into the soil, providing effective erosion control and filtering of stormwater.
- Berms/socks can be installed at the base of slopes with gradients of 2H:1V or less (for steep slopes, berms/socks can be installed, on contour, to reduce slope length).
- Berms/socks are installed perpendicular to sheet flow, allowing run-off to be intercepted, detained and filtered. Filter socks can be staked in channels (as temporary check dams) to reduce the velocity of low to moderate flows (control channel erosion).
- Filter socks are flexible and can be filled in place or filled and moved into position, making them especially useful on steep or rocky slopes.
- A range of biodegradable and synthetic mesh casing is available for compost socks. Mesh encased compost socks can be constructed in a variety of diameters and lengths, as dictated by the specific application. Compost socks provide added structural stability to the compost, allowing application for areas such as steeper slopes, low flow channels and for stream bank/shoreline bioengineering projects.
- Compost is organic, biodegradable, renewable, and can be left onsite. This is particularly important adjacent to water bodies or other environmentally sensitive areas (where re-entry to remove or maintain the berm/sock can cause additional disturbance). The added cost of removing and disposing of silt fence can be high.
- The flexibility, continuity and weight of berms and filter socks allows for good conformity and surface contact with site soils, reducing the potential for undermining.
- Installation does not require disturbing the soil surface, which reduces erosion potential.

- Compost retains a large volume of water, which results in reduced erosion potential and aids in vegetation establishment.
- The gradation of particle sizes in compost berms and socks provides more effective filtration of sediment-laden run-off than traditional controls such as silt fence (which often becomes clogged with sediment, creating a dam).
- In addition to retaining sediment, compost can adsorb stormwater contaminants such as heavy metals, nutrients, pesticides and hydrocarbons. Microorganisms in the compost matrix can further reduce nutrients and hydrocarbons by decomposition.

Limitations

- Only suitable for detention and filtration of sheet run-off or (for socks) low to moderate channel flow.

Implementation

Design Considerations:

- Use only sanitized, mature compost that meets all local, provincial and federal (CCME Category A) requirements.
- To maximize effective filtration, compost should consist of both large and small fragments. Finer grades (screened through 10 – 15 mm) have increased nutrient availability, promoting vegetative cover. Inclusion of coarser grades (up to 75 mm) promotes filtration and improves the structural integrity of berms exposed to wind, rainfall and run-off. A 1:1 ratio of coarse:fine material is recommended for berms.
- For application, a moisture content of 25 – 40% is optimal: Compost that is too dry is harder to apply, while wet compost is heavier and expensive to transport.
- Compost should be free of weeds, weed seeds, pesticide residues and

garbage. Construction Considerations:

- For compost berms, ensure that the base is about twice the height of the berm. For berms installed at the toe of 3H:1V or gentler slopes, install a compost berm 0.3 m high and 0.6 m wide at the base. For steeper slopes, or where additional berms are installed on the slope, typical berm dimensions are 0.45 m high x 0.9 m base. Where additional structural stability and integrity is required, a compost sock should be considered.
- Berms/socks installed on a slope are typically spaced at 5 – 9 m and are often used in conjunction with a suitable compost or mulch blanket.
- Berms/socks should be placed so as to detain and filter run-off (use “smile” or “J-hook” configurations). On steeper slopes, berms/socks may be installed along the contour (perpendicular to flow) at intervals down the slope (to reduce slope length, thereby reducing the potential for rills to develop). At the base of slopes, berms/socks are best placed at least 2 m from the slope toe.
- Ensure upstream run-off is captured and diverted away from exposed slopes or safely conveyed down the slope in a suitable channel or slope drain.
- Compost socks applied as check dams in low flow channels should be adequately staked in place, with scour protection installed immediately downstream. Ensure the ends of socks are adequately extended up the sides of the channel to prevent water flowing around these controls.

Inspection and Maintenance

- Except during freeze-up and prior to permanent stabilization of the contributing area, compost berms/socks should be inspected a minimum of every seven days and following significant rainfall or snowmelt likely to cause erosion. Any necessary repairs should be completed as soon as possible.
- Additional erosion protection should be installed on slopes experiencing rill erosion.
- Sediment retained by the berm or sock should be removed when it has reached 1/3rd of the exposed height of the berm.
- Berms can be left onsite and vegetated, or spread out in place as a soil amendment. Likewise, socks can be vegetated and left in place, or the mesh split, removed and the compost spread out.



Photo 21: Combination of compost socks and a compost blanket applied to control erosion adjacent to a sensitive creek. A design seed mix was incorporated with the application, resulting in long-term erosion control. Biodegradable compost sock liners are also available.

BMP 23	SILT FENCE	Sediment Control
---------------	-------------------	-------------------------

Note: Silt fence is a **sediment control practice** (occasionally used as a temporary diversion structure) intended to supplement appropriate upstream run-off and erosion controls.

Definition and Purpose

- Silt fence is a permeable geotextile barrier installed vertically on support posts and entrenched in the ground. Silt fence is installed along contours and in “smile” and “J-hook” patterns designed to detain sediment-laden sheet flow from small, disturbed areas.
- Properly designed, installed sections of silt fence can capture sand and coarse silt-size particles (while silt fence may provide some limited filtering of sediment-laden water, it is most effective at providing temporary detention of sediment-laden run-off, allowing settling of coarse sediment).
- In combination with upstream erosion and run-off controls, silt fence can be an effective way to capture and settle coarse sediment from small areas subject to sheet flow.
- Silt fences generally have a useful life of one up to season (dependent on the amount of maintenance required).

- **All stages of construction**
- **Perimeter control for stockpiles, slopes and site perimeters**

Applications and Advantages

- Silt fence is only suitable for detaining sediment-laden flow from locations generating low volume overland sheet flows.
- Silt fence is most effective for trapping larger particle sizes (coarse silt to sand): Finer-size material (fine silt and clay- size) is not detained.
- Silt fence is a suitable practice for the toe of short, exposed cut and fill slopes, as a contour boundary between a construction site and other critical areas such as environmentally sensitive areas and as a stockpile perimeter control.

Silt Fence Slicing Machines

Silt fence machines install silt fence by slicing through the soil, removing the need for excavating and backfilling. Sliced in fence requires one pass on each side with a tractor tire. Compacted soil resists water infiltration and moisture saturation, reducing the risk of washouts. Slicing machines are capable of turning in a short distance. Turning enables installation of upturns on the ends of silt fence runs. Slicing generally works well in soils, except excessively rocky ground.

Limitations

- Improperly applied or installed silt fence can increase erosion.
- Failure to properly plan, install, inspect and maintain silt fence can result in major sediment releases.
- Silt fence is a temporary sediment control practice, requiring a high degree of inspection and maintenance. As a temporary practice, silt fence should be removed when the contributing area is stabilized.
- Silt fence should be considered, wherever possible, as a “last line of defence”. There is no substitute for controlling upstream run-off and erosion.
- Long, continuous runs of fence concentrate run-off and commonly lead to failures.

- Do not install silt fence at locations where concentrated run-off occurs or may occur. Silt fences are not designed to withstand high heads of water. Concentrated flows rapidly undercut silt fence or knock it over, a common cause of fence failure and a major cause of off-site sediment releases.
- Silt fence is not effective unless properly sliced or entrenched and compacted into the ground.
- Silt fence should not be designed to impound sediment or water more than 0.5 m high.
- Silt fence does a poor job of controlling clay and fine silt in sediment-laden run-off: Run-off is usually not detained long enough to allow settling of fine soil particles (designers should consider site soils and include appropriate source and detention controls to prevent releases of sediment off-site). Clays and fine-silts can have extremely deleterious impacts on receiving water-courses and off-site areas.
- Installation – by trenching or slicing – can be difficult in compacted or rocky ground or where there is dense vegetation and roots.
- Do not place silt fence on a slope. Unless intended as a diversion, long runs of silt fence that do not follow a contour can cause diversion of run-off, resulting in washouts at low spots.

Implementation

- Clean run-off should be diverted away from sediment containment controls such as silt fence.
- Always determine how run-off volume is going to exit. Contributing drainage area (followed by soil type) is the primary consideration when determining silt fence suitability, location and quantity.
- Ensure the maximum area draining to silt fence is 0.1 ha (1/4 acre) per 30 m of fence: This area should be reduced when silt fence is installed at the toe of steep slopes.
- Maximum sedimentation behind the fence should not exceed half the fence height or 0.3 m.
- Silt fences are not to be constructed in areas where flow velocity is expected to exceed 0.03 m/sec.
- Steel posts (minimum 2 kg/m with projections for fastening fence), driven 600 mm into the ground are recommended. Wood posts (100 mm in diameter, with a minimum length of 1.35 m) are an alternative, but may be difficult to drive 600 mm into the ground or may not be reusable.
- Adequate post spacing and proper entrenchment of fence are the two most critical installation requirements.

Note: Avoid using wire backing for fence reinforcement: Wire backing is unnecessary for properly located and installed silt fence and is an added expense to install, remove and dispose of. For suitably located silt fence, the proper entrenchment and compaction of the fence material into the ground and the use of steel T-posts, driven 600 mm into the ground and spaced at 2 m intervals are critical. Silt fence can be supported by clipping the top of the fence to a horizontal support wire between posts.

Location Requirements:

- Contributing drainage area should not exceed 0.1 ha per 30 m of fence.
- The run-off path length above a fence should not exceed 30 m.
- Maximum slope gradient upstream of a fence should not exceed 2H:1V.
- Unless intended as a temporary diversion structure, silt fence should be installed along a contour, with ends of the fence pointed upslope.

- Silt fence installed around a construction site perimeter should have a suitable number of J-hooks installed so that contributing drainage area is limited to 0.1 ha per 30 m of fence.

- Fence should be installed at least 2 m from the toe of a slope.
- Fence should not be used in drainage swales, except for very low volume swales (flow velocity < 0.03 m/sec) with grades not exceeding 2% and contributing areas not exceeding 0.8 ha.
- The designer should consider the erodibility of the exposed soil in determining silt-fence requirements and suitability (for example: silty sand may result in more silt fence maintenance and need for more source control than a less erodible clayey soil).

Installation Requirements:

- Silt fence should be firmly entrenched and anchored into the soil.
- Fence height should not exceed 0.9 m. However, the ponding height of water should not exceed 0.5 m (install stabilized overflow sections on long runs of fence).
- Silt fence should be firmly attached to posts (steel T-posts or 100 mm (4") diameter wood stakes), driven at least 600 mm into the ground on the downstream side of the fabric.
- Minimize joints by installing fence from a continuous roll. Where joints are required, construct at least a 0.4 m overlap and wrap the end posts together.
- Run-off detention requires storage space behind the fence. Fences constructed on a slope have considerably less retention capacity. Always install the fence at least 2 m from the toe of slopes.
- The maximum length of each run of silt fence should generally not exceed 40 m.
- To ensure the stability of the fence, and provide safe overflow, install one or more reinforced outlets. The distance between the outlet posts should not exceed 1.2 m. Install a 50 mm x 100 mm (2 x 4 ") wood brace horizontally between the posts. Install a splash pad on the down-slope side of the outlet by using riprap or a small section of erosion control blanket.
- When replacing or removing silt fence, ground disturbance can be reduced by cutting the fence at ground level, leaving the trenched-in portion of fence in the ground.
- Seed and mulch any areas of soil disturbed by fence replacement or final removal.

There are two methods of keying the fence into the ground: Trenching and mechanical slicing:

Trenching Method:

- Excavate a trench approximately 0.15 m deep by 0.15 m wide for the entire length of the fence.
- Drive the support posts 600 mm into the ground, with 2 m maximum post spacing, on the downstream side of the fence.
- Attach the fabric (using wire ties) on the upstream side of the posts, with at least 0.3 m of fabric laid in the trench. Fence material can be clipped to a horizontal support wire run between posts
- Backfill the trench and compact with a machine tamper or tractor tire, taking care not to damage the fence.

Mechanical Slicing Method:

- The slicing method for silt fence installation utilizes an implement pulled behind a tractor to "plough" or slice the silt fence material into the soil. Slicing minimally displaces the soil, creating an optimal condition for future mechanical compaction. Compacted soil resists water infiltration and moisture saturation, reducing the potential for undermining.
- Use this method to slice fence at least 0.15 m into the ground. Provide compaction by running a tractor tire along both sides of the fence.
- Follow the same guidelines as trenching for support posts, fabric attachment and compaction.

Inspection and Maintenance

- Inspect this sediment control practice a minimum of every seven days and after significant rainstorm/snowmelt events sufficient to cause surface run-off.
- Ensure silt fences are providing the required detention of run-off and sedimentation.
- Except where used as a temporary diversion, ensure silt fence is installed on contour (or in effective “smile” or “J-hook” configurations), with end sections of fence pointed upstream.
- Do not accept long, linear runs of silt fence installed without J-hooks or “smiles”.
- Check all sections of fence for adequate entrenchment by pulling firmly upwards on the fence (fence which moves is not adequately trenched/sliced and compacted).
- Check all sections of fence are firmly secured to posts. Ensure post spacing does not exceed 2 m.
- Ensure stabilized overflows are installed at least every 30 m on long runs of fence. Poned water should not exceed 0.5 m depth.
- Remove accumulated sediment when it reaches 50% of impoundment height (i.e. 0.25 m).
- Replace damaged fabric and address flow-around and/or undermining problems immediately.
- Silt fence is a temporary sediment control practice: Remove and appropriately dispose of fence as soon as the contributing area is stabilized.

Construction Details

Refer to figures:

Traditional Trenching Method for Silt Fence Installation

Typical Installation Detail for Silt Fence

Silt Fence Placement on Complex Slopes

Silt Fence Placement for Perimeter Control

MAINTENANCE

THE FABRIC IS TO BE INSPECTED AND REPAIRS COMPLETED AFTER EVERY STORM EVENT. SEDIMENT DEPOSITS SHALL BE REMOVED ONCE COLLECTED MATERIAL REACHES A DEPTH OF ONE-HALF THE FENCE HEIGHT.

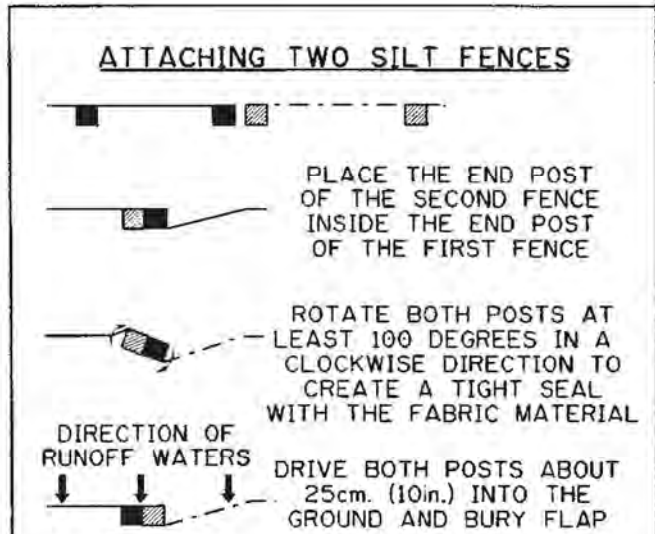
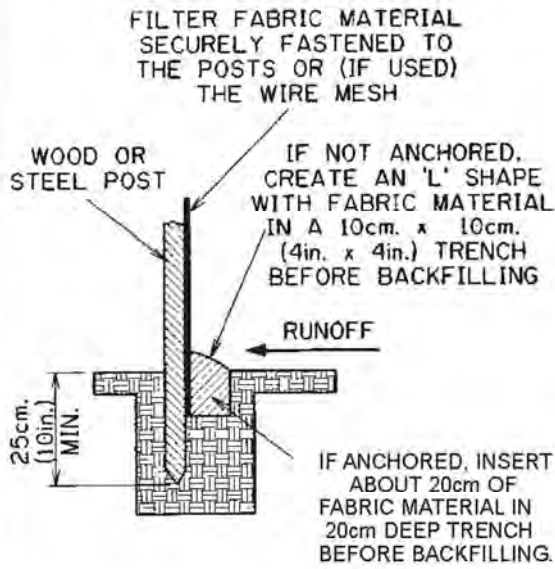
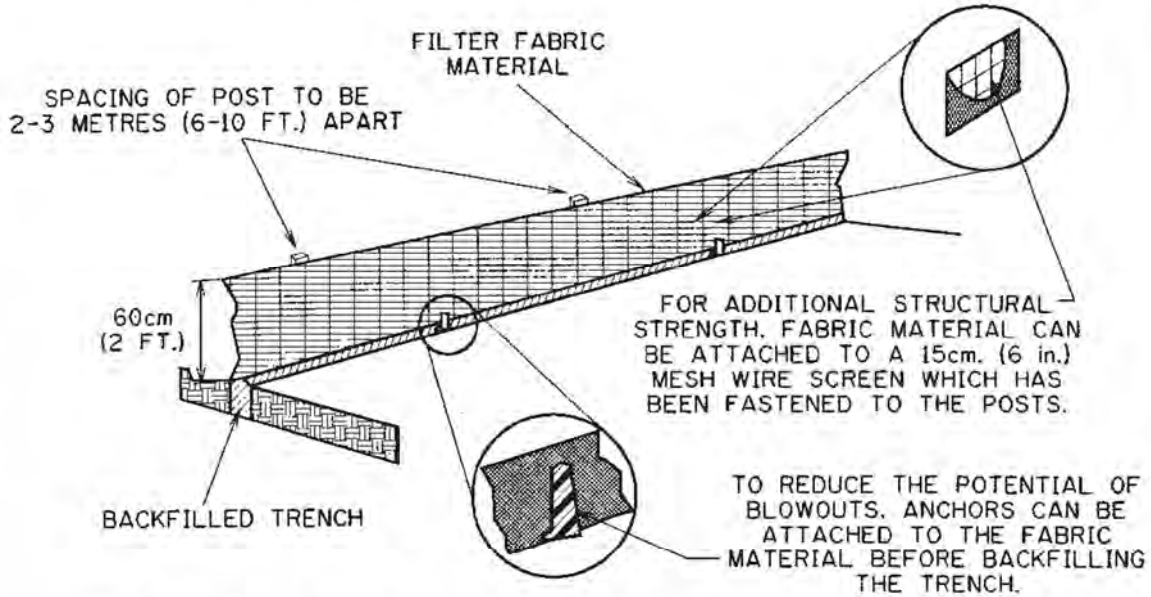

DIMENSIONS ARE MILLIMETRES UNLESS OTHERWISE NOTED METRIC

Drawn: LC 000329 Checked: [] Date: M.T.S. Approved by: [] For City Engineer: []				THE CITY OF CALGARY ENGINEERING AND ENVIRONMENTAL SERVICES DEPARTMENT SILT FENCE INSTALLATION		Sheet: [] File Number: []
No.	Date	Revised	App'd			

Traditional Trenching Method for Silt Fence Installation

J-HOOKS OR 'SMILES' ARE PREFERABLE TO LINEAR INSTALLATION

USE STEEL T-POST IF CANNOT ACHIEVE 500MM DEPTH WITH WOOD POSTS.

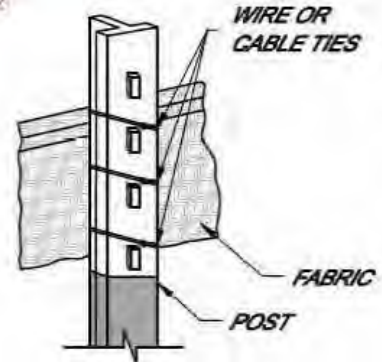
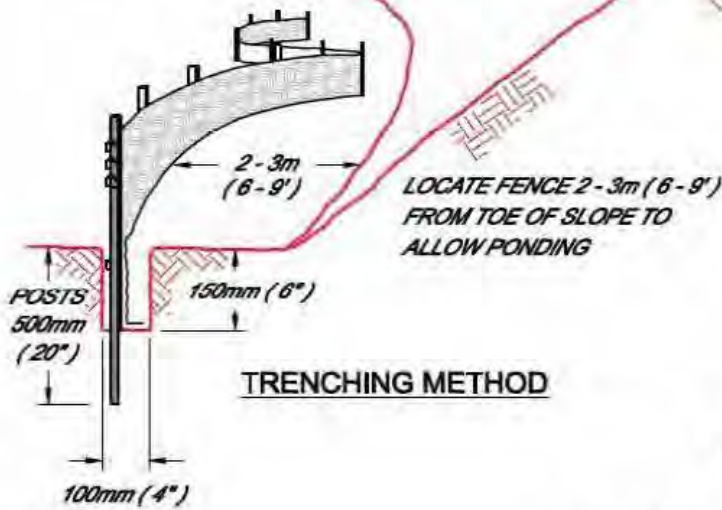

T-POST WITH ATTACHMENT TO POST

STATIC SLICING METHOD BACK VIEW

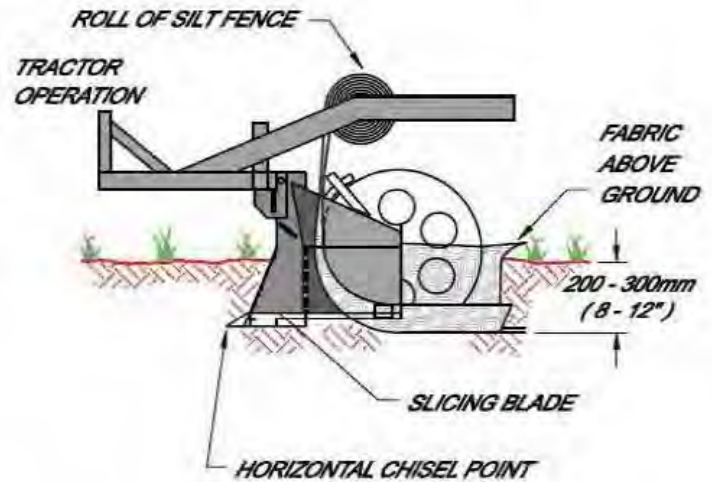
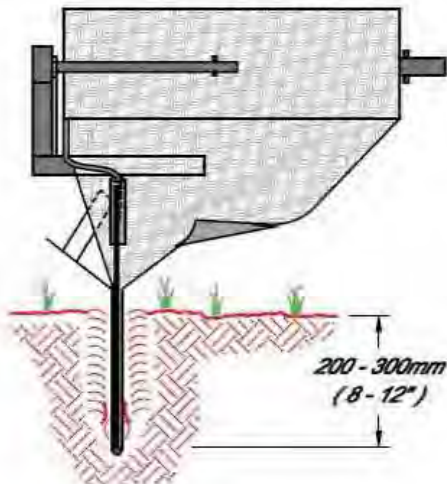

STATIC SLICING METHOD SIDE VIEW

Silt Fence Installation



Erosion & Sediment Control Guidelines 2011

Source: Salix Applied Earthcare - Erosion Draw 5.0
 © 2001 JOHN McCULLAH FILE: sf_methods.dgn

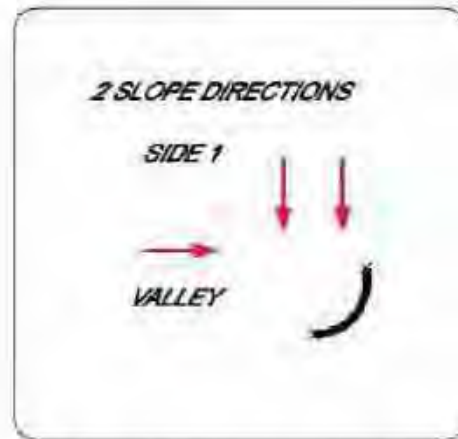
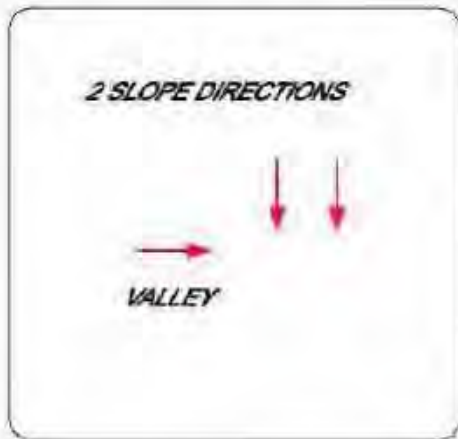

STEP 1 - CONSTRUCT A DAM

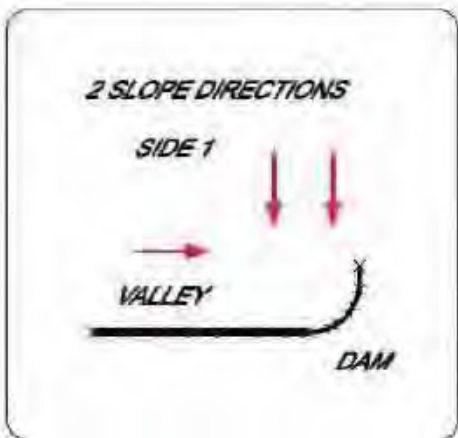

STEP 2 - CONSTRUCT SIDE 2

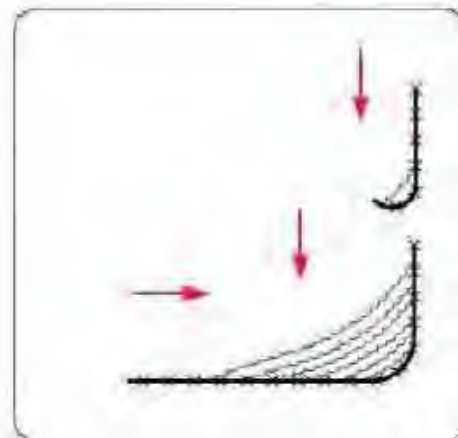

STEP 3 - CONSTRUCT J-HOOKS AS NEEDED

INSTALLATION WITH J-HOOKS WILL INCREASE SILT FENCE EFFICIENCY AND REDUCE EROSION-CAUSING FAILURES.

Silt Fence Typical Placement - Two Slopes



Erosion & Sediment Control Guidelines 2011

Source: Salix Applied Earthcare - Erosion Draw 5.0
 © 2001 JOHN McCULLAH FILE: sf-two_slopes.dgn

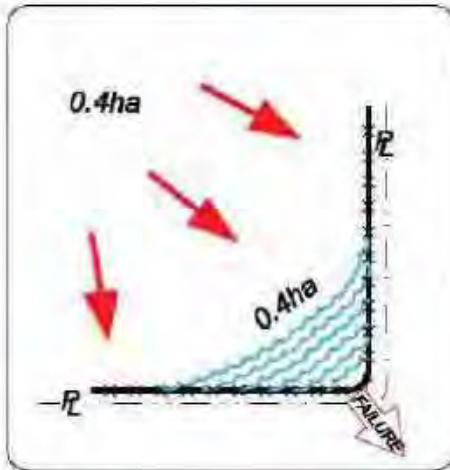

Incorrect

Do Not layout "perimeter control" silt fences along property lines. All sediment laden runoff will concentrate and overwhelm the system.

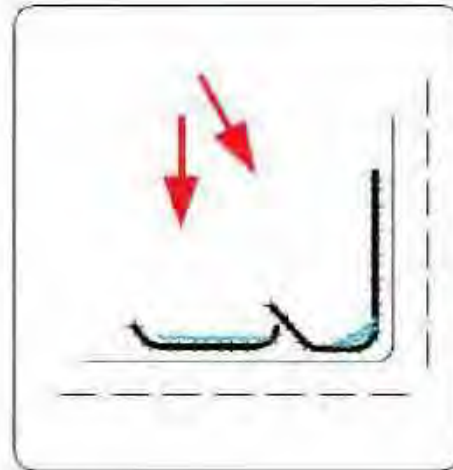

Correct

Install J-hooks

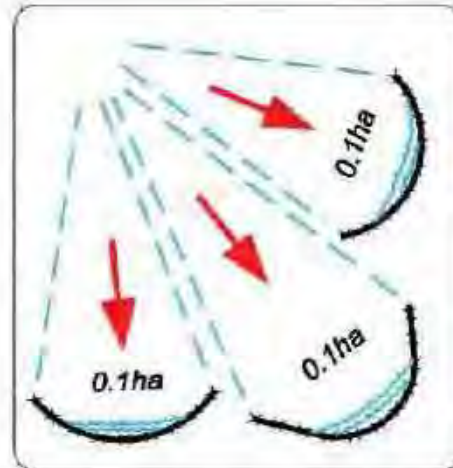
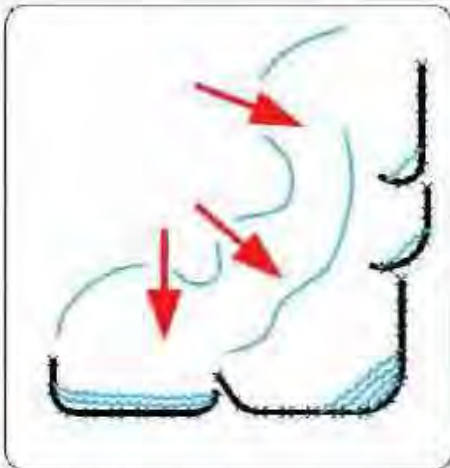

Discreet segments of silt fence, installed with J-hooks or 'smiles' will be much more effective.

Silt Fence Placement for Perimeter Control



Erosion & Sediment Control Guidelines 2011

Source: Salix Applied Earthcare - Erosion Draw 5.0
 © 2001 JOHN McCULLAH FILE: sf-perimeter_control.dgn

BMP 24	FLOCCULANTS AND COAGULANTS	Sediment Control
---------------	-----------------------------------	-------------------------

Description and Purpose

Fine silt and clay-size particles typically carry a negative charge, causing particles to repel each other and further increasing particle settling time (due to their small size and repulsion, they are commonly referred to as colloids). Low dosage of chemicals known as flocculants and coagulants (containing highly charged polymer chains or ions) destabilises negative charges on fine particles, allowing material to aggregate and settle. Two classes of flocculant and coagulant chemicals that are commonly used for erosion control and water clarification will be discussed.

- **Construction Dewatering**
- **Temporary Erosion Control**

Anionic polyacrylamides (PAMs) are a class of synthetic water-soluble polymer (composed of long chains of acrylamide monomer) flocculants. Anionic PAMs are available in dry powder form, liquid emulsion, and gelatinous blocks. Anionic PAMs increase the aggregation of clay and fine silt-size particles, improving soil structure and permeability and reducing particle detachment and entrainment by raindrops, run-off and wind. Anionic PAMs can be applied to exposed soils in dry granular form, dissolved in water or as an emulsion. In addition, anionic PAMs are available as slow-dissolving gel blocks for *in situ* removal of fine solids from water. Care should be taken to always consult with the manufacturer and distributor to ensure any product will be used in a way that will not result in any adverse impacts to downstream receiving waters. Also be sure to check that independent toxicity data is available and check that products are non-toxic.

Chitosan Based Products are manufactured from chitosan, a flocculant derived from shrimp shells. Chitosan has very low solubility in water and sometimes needs to be solubilized in solutions such as lactic acid or acetic acid. Care should be taken to always consult with the manufacturer and distributor to ensure any product will be used in a way that will not result in any adverse impacts to downstream receiving waters. Also be sure to check that independent toxicity data is available and check that products are non-toxic. Chitosan combines with phosphorus, suspended solids, metals, and other dissolved and suspended matter (flocculation). The insoluble precipitates that are formed from this process are stable. Even if chemical is added at a dosage in excess of that required for effective removal of solids and nutrients, the dissolved aluminium is still reduced very rapidly to a low concentration with no serious toxicity implications.

Note: To optimize performance, flocculants and coagulants are generally applied at very low, calculated doses. Preliminary site-specific assessment (requiring basic soil and water sampling and analysis) is generally required (to determine dosing rate, method and maintenance requirements).

Applications and Advantages

- Chitosan is commonly used as a flocculant in long-term construction dewatering activities (to complement other dewatering practices when fine silt and clay-size material is unavoidably suspended in water).
- Anionic PAMs are intended for use on areas that contain high amounts of fine silt, clay, or colloidal soils. PAMs can be soil applied (to improve soil structure and reduce erosion by wind or water) or to treat sediment-laden water upstream of retention or detention controls. Anionic PAMs complement the use of other ESC practices when the timely establishment of vegetation may not be feasible or

adequate, or where conventional temporary ESC is limited (i.e. limited by other construction requirements).

- Chitosan and Anionic PAMs – selected on the basis of site-specific soil and water quality information and applied at low dosages - are non-toxic to aquatic life.
- Aggregation improves the resistance of fine-grained soils to particle detachment and entrainment by wind (dust control) and water, providing temporary protection for exposed soils prior to final stabilization.
- In situ flocculation or coagulation of fine silt and clay-size particles enhances particle settling and complements other sediment control practices.

Limitations

Note: Cationic PAM products must never be used as they are toxic to fish at extremely low levels (bind to fish gills and cause suffocation).

- Product effectiveness is affected by soil texture and – to a degree – soil chemistry: This requires site- specific soil information. This may limit product bulk ordering or reuse on multiple sites. Soil sampling and analysis may take several days to complete.
- For effective in situ water treatment, mechanical mixing or agitation may be required after introduction of the product to water.
- Flocculants and coagulants may enhance precipitation of fine sediments in downstream sediment control structures, increasing maintenance requirements (removal of sediment).
- Over-dosage of product can cause dispersion of fine particles, negatively impacting soil structure and particle settling in water.
- Flocculants and coagulants are intended to complement conventional ESC practices and are not a substitute for timely planning and implementation of suitable ESC practices.
- The effectiveness of some products can be affected by temperature. The manufacturer should account for this when providing specific product and dosing rate recommendations.

Implementation

Chitosan Product Requirements

- Product should be environmentally benign, harmless to fish, aquatic organisms, wildlife, and plants.
- Product should be non-combustible.
- Should not change soil or water pH.
- An expiration date should be provided with the product.
- Products should be accompanied by MSDS and toxicity information from the manufacturer confirming that the product and any required additives cause no acute or chronic toxicity to aquatic biota.
- Products and any required additives should be on the Canada Domestic Substances List (have a CAS registry # from Environment Canada). The manufacturer or supplier should be able to provide CAS numbers.
- To ensure proper product selection, site preparation, application, inspection, maintenance, storage and safe use, products should be accompanied written instructions from the manufacturer.

Anionic PAM Product Requirements

Only Anionic PAM products meeting the following criteria are acceptable for use:

- Anionic PAM mixtures should be environmentally benign, harmless to fish, aquatic organisms, wildlife, and plants.
- Anionic PAM mixtures shall be non-combustible.
- PAM copolymer formulation should be anionic (negatively charged), with a charge density of 8 to 35% by weight (15-18% is typical) and ultra high molecular weight of 6 to 24 mg/mole (preferably 12-15 mg/mole).
- Product should be water-soluble and linear (not cross-linked). Residual acrylamide monomer should not exceed 0.05 % by weight.
- Should not change soil or water pH.
- An expiration date should be provided with the product.
- Products should be accompanied by MSDS and toxicity information from the manufacturer confirming that the product and any required additives cause no acute or chronic toxicity to aquatic biota.
- Products and any required additives should be on the Canada Domestic Substances List (have a CAS registry # from Environment Canada). The manufacturer or supplier should be able to provide CAS numbers.
- To ensure proper product selection, site preparation, application, inspection, maintenance, storage and safe use, products should be accompanied written instructions from the manufacturer.

Site-Specific Testing Requirements

- To ensure that the product, additives and the application are tailored to site-specific soil and water quality and conditions generally requires sampling and analysis of site soils or water.
- For anionic PAM to work effectively there should be a source of divalent cations (i.e. Ca^{2+}). Gypsum (CaCl_2) is a common source. The divalent cation source may be in the anionic PAM mix, in the soil, or applied directly to the soil. Soil tests should be conducted to determine whether additives are necessary.

Application

- Always follow product handling guidelines provided by the manufacturer (MSDS and other information).
- For in situ water treatment, products should always be incorporated and mixed with water prior to a pre-constructed sediment trap or settling tank. Never apply products directly to slopes that drain directly to a water body or directly into sediment tanks, basins or traps.
- For in situ water treatment, Chitosan can be introduced in a solid form (by running water to be treated through tubes containing belts of the slowly soluble product) or injected (by controlled dosage) into a pipe or mixing chamber in the sedimentation tank. Set-up and monitoring of the system generally requires the expertise of a water treatment specialist.
- Do not over-dose or over-apply product. Excessive application can disperse fine particles, destabilizing soil aggregates and increasing in situ particle settling time in water.
- Avoid using PAM products on paved surfaces as slippery conditions can result.
- Do not add water to powdered Anionic PAM. Add Anionic PAM powder slowly to water to the desired concentration and mix for 3 to 5 minutes. If water is added to PAM, globs may form that can clog dispensers.
- Including tackifiers, mulch, seed, and fertilizer in the final Anionic PAM mixture is recommended to improve performance and provide additional permanent protection beyond the useful life of the Anionic PAM. However, Anionic PAM should always be the final additive to the mixture.

- Effectiveness of PAM has been shown to decrease if too much time passes between mixing and application.
- Anionic PAM may be sprayed on bare soil using standard irrigation equipment, hydroseeding/hydromulching equipment, water trucks, or other spraying devices that have a mechanical agitator, mixing apparatus, or recirculation.

Inspection and Maintenance

- Monitor all areas treated with anionic PAM products after every precipitation event and until treated areas are permanently stabilized.
- All equipment should be maintained so as to provide the required application or dosage rates. Rinse all equipment used to mix or apply Chitosan or Anionic PAM thoroughly with water to avoid formation of residues.
- Conduct frequent turbidity monitoring, upstream and downstream of the application, with a calibrated, handheld turbidity meter. Implement mitigation or contingency measures if turbidity in the discharge exceeds allowable values.
- Products may enhance precipitation of fine sediments in sediment settling structures. Accordingly, these structures should be inspected periodically and sediment removed in accordance with the maintenance schedule recommended for the particular measure. Never discharge from the site water that may contain excess product or material that could precipitate in pipes or a water body.

Appendix B Referenced Drawings

Drawing No.	Title
1016-C11-00803	RSEM Area L5 Reference Concept, Plan and Section, Water Management
1016-C11-00809	RSEM Area L6 Reference Concept, Plan, Water Management
1016-C11-00812	RSEM Area 5a Reference Concept, Plan, Water Management
1016-C11-00818	RSEM Area L6 Reference Concept, Plan, Sections and Detail, Water Management
1020-C18-00407	Reservoir - Left Bank Excavation, Excavation and Drainage - Stage 1, Plan and Section

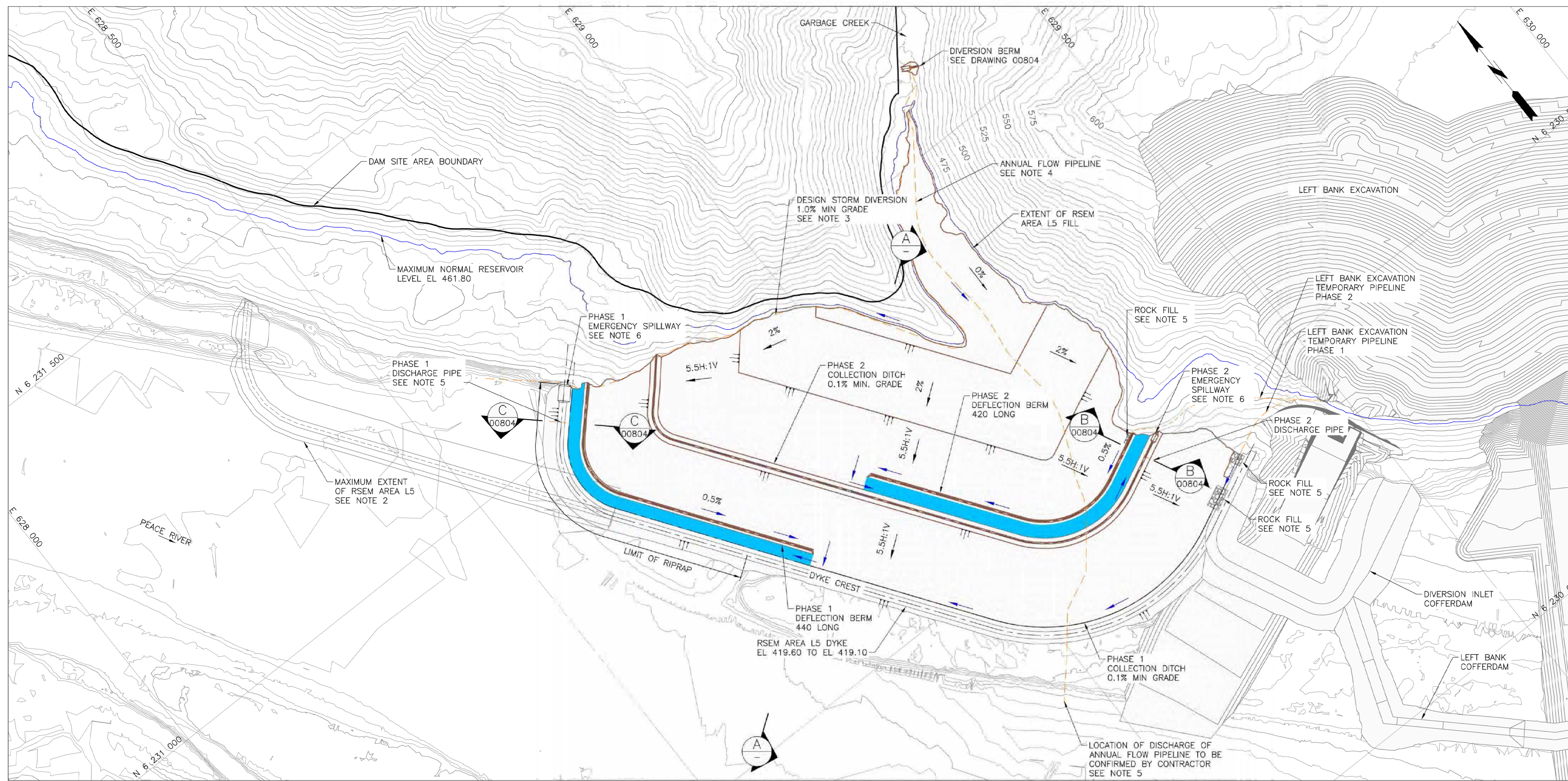

PLAN
1:2500

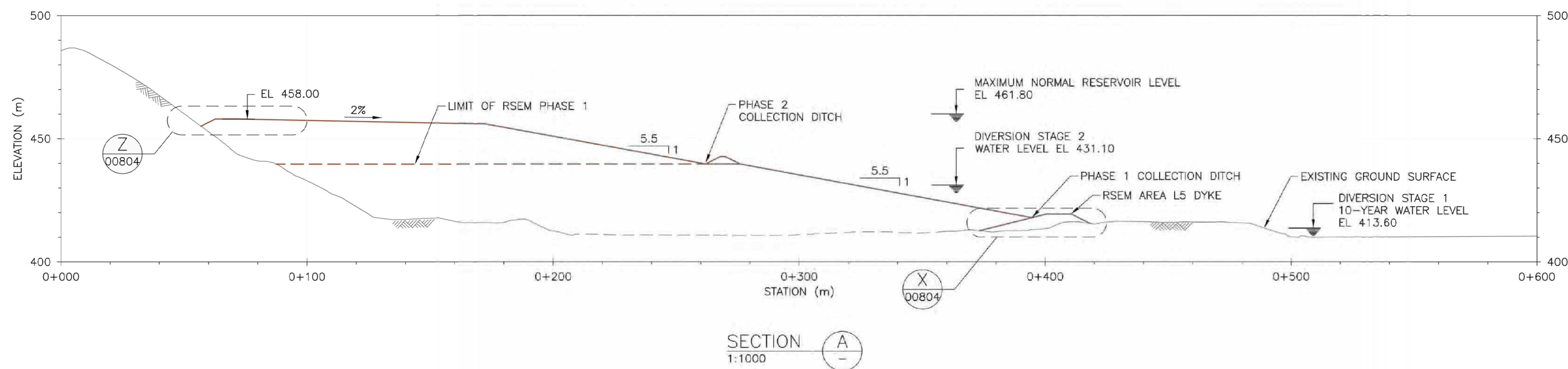

SECTION
1:1000

- NOTES:
- EXISTING GROUND SURFACE DERIVED FROM 2006 LIDAR SURVEY.
 - LATERAL EXTENTS OF RSEM AREA SHOWN ARE THE MAXIMUM ALLOWED. ACTUAL LONGITUDINAL EXTENTS OF RSEM AREA SHALL BE DETERMINED ACCORDING TO ACTUAL SURPLUS MATERIAL TO BE DISPOSED OF.
 - ALIGNMENT OF DESIGN STORM DIVERSION SHALL BE FIELD FITTED TO SUIT CONSTRUCTION ACTIVITY. DIVERSION SHALL BE DESIGNED FOR A MAXIMUM FLOW OF 4.0 m³/s.
 - ANNUAL FLOW PIPELINE ALIGNMENT SHALL BE FIELD FITTED TO SUIT CONSTRUCTION ACTIVITY. PIPELINE SHALL BE DESIGNED FOR MAXIMUM FLOW OF 0.3 m³/s.
 - ENERGY DISSIPATION INFRASTRUCTURE SHALL BE DESIGNED TO SUIT CONSTRUCTION ACTIVITY AND MAXIMUM FLOWS.
 - EMERGENCY SPILLWAY SHALL BE DESIGNED TO SUIT CONSTRUCTION ACTIVITY.
 - DRAWING SHALL BE READ IN CONJUNCTION WITH REFERENCE CONCEPT REPORT.

- LEGEND:
- EXTENT OF SEDIMENT POND AREA
 - RSEM RELOCATED SURPLUS EXCAVATED MATERIAL
 - RUNOFF FLOW DIRECTION

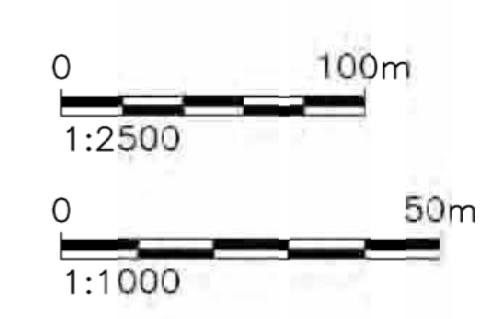

ISSUED FOR DATA ROOM
NOT FOR CONSTRUCTION

ALL DIMENSIONS ARE IN METRES UNLESS NOTED OTHERWISE

		<p>INTEGRATED ENGINEERING TEAM</p>	
<p>DSGN: MJ. PIGGOTT INDEP CHK: H. MCLEOD DFTG: LH DFTG CHK: MJP INSP: BM</p>	<p>DATE: 25 NOV 2014 DST: - DWG NO: 1016-C11-00803</p>	<p>SITE C CLEAN ENERGY PROJECT DATA ROOM RSEM AREA L5 REFERENCE CONCEPT PLAN AND SECTION WATER MANAGEMENT</p>	
<p>REV: G. STEVENSON ACPT: J.NUNN A.HANNA A.WATSON</p>	<p>DATE: 25 NOV 2014 DST: - DWG NO: 1016-C11-00803</p>	<p>SIZE: A0 R: 0</p>	<p>ORIGINAL SEALED BY H. MCLEOD 25 NOV 2014 P.ENG. APEGBC</p>

N:\Projects\2014\1016-C11-00803\000.dwg
 17/11/2014 5:38 PM
 B:\Projects\2014\1016-C11-00803\000.dwg
 17/11/2014 5:38 PM

REF#	DRAWING NUMBER	TITLE	REF#	DRAWING NUMBER	TITLE	NO	REMARKS	DATE	DESIGNED	INDEP CHK	DFTG	DFTG CHK	INSP	REV	ACPT
		REFERENCE DRAWINGS			REFERENCE DRAWINGS										

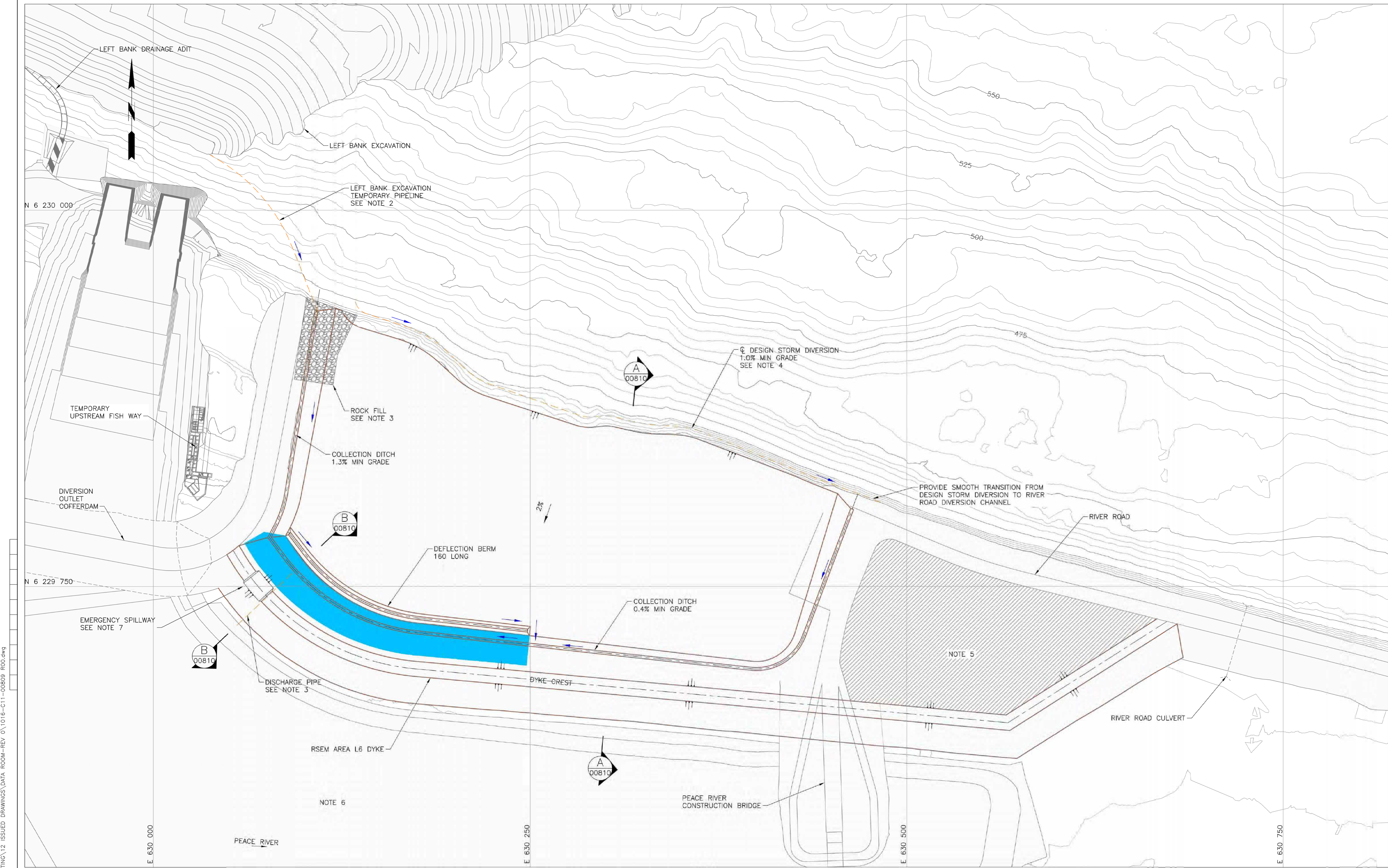

PLAN
1:1000

- NOTES:
- EXISTING GROUND SURFACE DERIVED FROM 2006 LIDAR SURVEY.
 - PIPELINE ALIGNMENT SHALL BE FIELD FITTED TO SUIT CONSTRUCTION ACTIVITY AND REMOVED IN ITS ENTIRETY AFTER CONSTRUCTION OF LEFT BANK EXCAVATION DRAINAGE SYSTEM IS COMPLETE.
 - ENERGY DISSIPATION INFRASTRUCTURE DOWNSTREAM OF ALL PIPELINE DISCHARGES SHALL BE DETERMINED DURING DETAIL DESIGN.
 - ALIGNMENT OF DESIGN STORM DIVERSION SHALL VARY TO SUIT CONSTRUCTION ACTIVITY. ULTIMATE CENTRELINE SHOWN.
 - ASSUMED EXTENT OF CONSTRUCTION PLATFORM BY SITE PREPARATION.
 - IN-RIVER ISLAND EXCAVATION IS NOT SHOWN.
 - EMERGENCY SPILLWAY SHALL BE DESIGNED TO SUIT CONSTRUCTION ACTIVITY.
 - DRAWING SHALL BE READ IN CONJUNCTION WITH REFERENCE CONCEPT REPORT.

- LEGEND:
- EXTENT OF SEDIMENT POND AREA
 - CONSTRUCTION PLATFORM (SEE NOTE 5)
 - RSEM
 - RUNOFF FLOW DIRECTION

ISSUED FOR DATA ROOM

NOT FOR CONSTRUCTION



ALL DIMENSIONS ARE IN METRES UNLESS NOTED OTHERWISE

DSGN	MJ. PIGGOTT	<div style="border: 1px solid black; border-radius: 50%; padding: 10px; display: inline-block;"> ORIGINAL SEALED BY H. MCLEOD 25 NOV 2014 P.ENG. APEGBC </div>						
INDEP CHK	H. MCLEOD							
DFTG	LH							
DFTG CHK	MJP							
INSP	BM							
		CIV	SIR	MECH	GEO	ELEC		
REV	G. STEVENSON						DATE	25 NOV 2014
ACPT	J.NUNN A.HANNA A.WATSON						DIST	-
				SITE C CLEAN ENERGY PROJECT DATA ROOM RSEM AREA L6 REFERENCE CONCEPT PLAN WATER MANAGEMENT		1016-C11-00809 A0 0		

REF#	DRAWING NUMBER	TITLE	REF#	DRAWING NUMBER	TITLE	NO	REMARKS	DATE	DESIGNED	INDEP CHK	DFTG	DFTG CHK	INSP	REV	ACPT
		REFERENCE DRAWINGS			REFERENCE DRAWINGS										

\\n:\data\proj\18_000-ML-RSEM\100 Drawings\12_ISSUED DRAWINGS\DATA ROOM-REV 0\1016-C11-00809 ROD.dwg
 BRIDGE, MICHAEL
 12/15/2014 5:43 PM

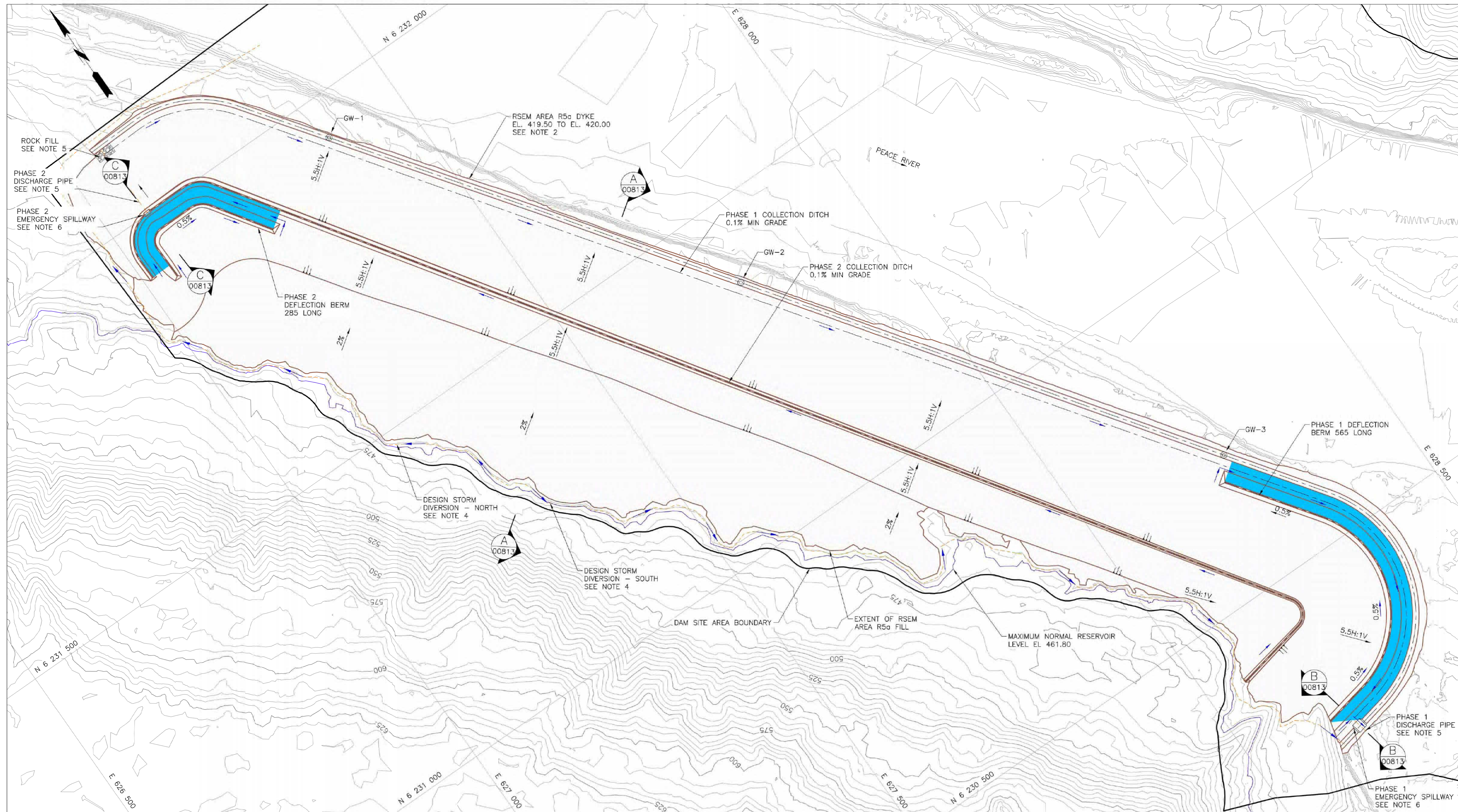

PLAN
1:2500

- NOTES:
- EXISTING GROUND SURFACE DERIVED FROM 2006 LIDAR SURVEY.
 - EXTENTS OF RSEM AREA SHOWN ARE THE MAXIMUM ALLOWED. ACTUAL EXTENTS OF RSEM AREA SHALL BE DETERMINED ACCORDING TO ACTUAL SURPLUS MATERIAL TO BE DISPOSED OF.
 - DRAWING SHALL BE READ IN CONJUNCTION WITH REFERENCE CONCEPT REPORT.
 - ALIGNMENT OF DIVERSIONS SHALL BE FIELD FITTED TO SUIT CONSTRUCTION ACTIVITY. DIVERSION SHALL BE DESIGNED BY CONTRACTOR FOR MAXIMUM FLOWS OF 1.2 m³/s (NORTH DIVERSION) AND 0.8m³/s (SOUTH DIVERSION).
 - ENERGY DISSIPATION INFRASTRUCTURE DOWNSTREAM OF ALL PIPELINE DISCHARGES SHALL BE DETERMINED DURING DETAIL DESIGN.
 - EMERGENCY SPILLWAY SHALL BE DESIGNED TO SUIT CONSTRUCTION ACTIVITY.

- LEGEND:
- EXTENT OF SEDIMENT POND AREA
 - GROUNDWATER MONITORING WELL
 - RUNOFF FLOW DIRECTION

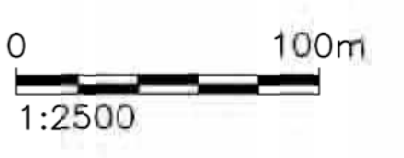

ISSUED FOR DATA ROOM

NOT FOR CONSTRUCTION

ALL DIMENSIONS ARE IN METRES UNLESS NOTED OTHERWISE

DSGN	MJ. PIGGOTT	<div style="border: 1px solid black; border-radius: 50%; padding: 10px; display: inline-block;"> ORIGINAL SEALED BY H. MCLEOD 25 NOV 2014 P.ENG. APEGBC </div>					
INDEP CHK	H. MCLEOD						
DFTG	LH						
DFTG CHK	MJP						
INSP	BM						
		CIV	STR	MECH	GEO	ELEC	
REV	G. STEVENSON	DATE	25 NOV 2014	DIST		DWG NO	1016-C11-00812
ACPT	J. NUINN A. HANNA A. WATSON	DATE	25 NOV 2014	DIST		SIZE	A0
						R	0

C:\Users\jmc\Documents\Projects\1016-C11-00812\1016-C11-00812_R00.dwg
 BRIDGEWATER\WCH\1016-C11-00812.dwg
 17/11/2014 6:01 PM

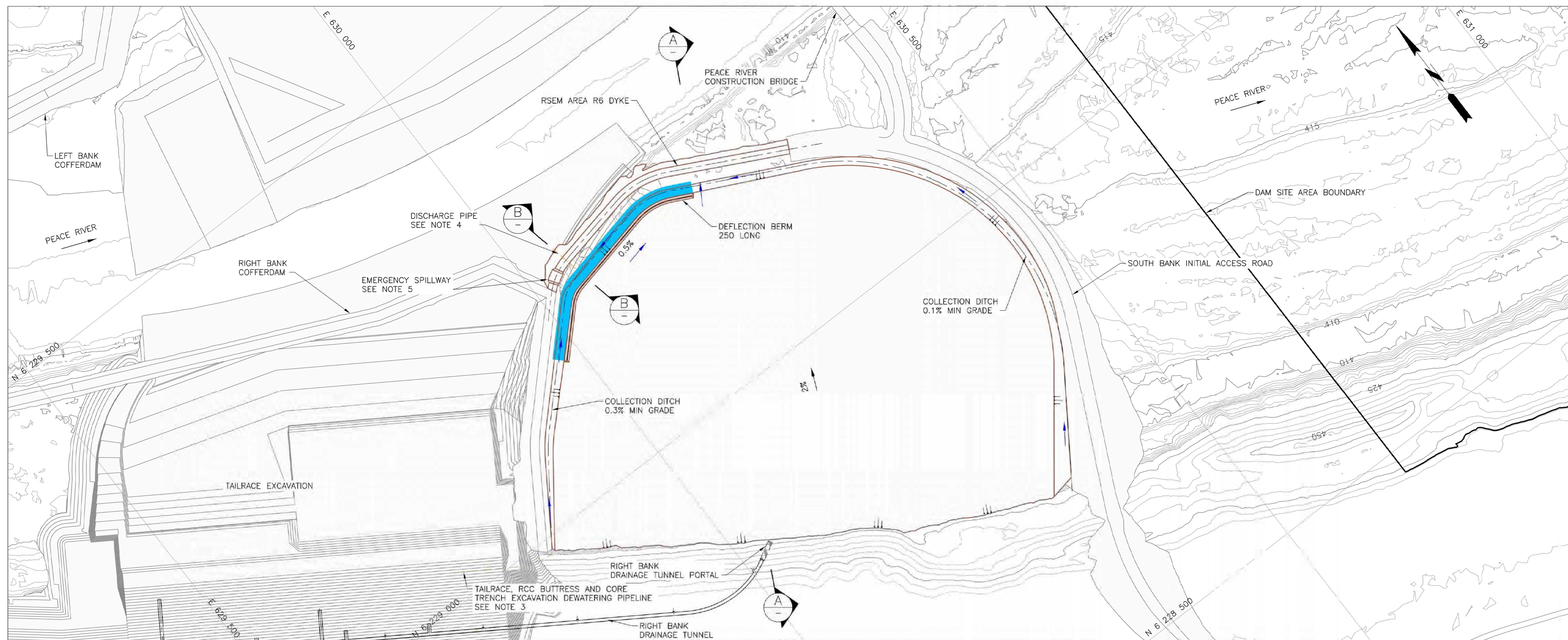

PLAN
1:2000

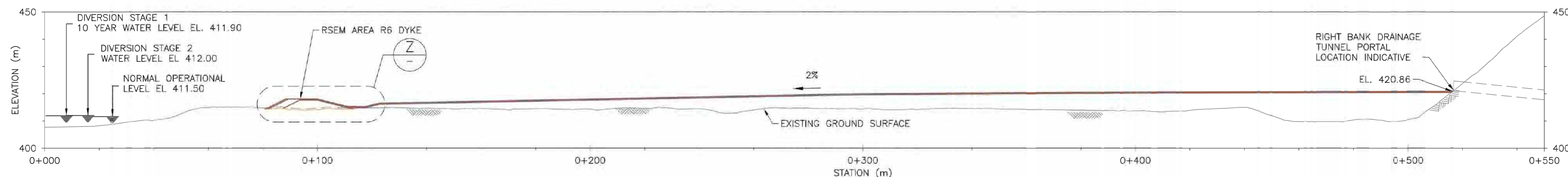

SECTION A
1:750

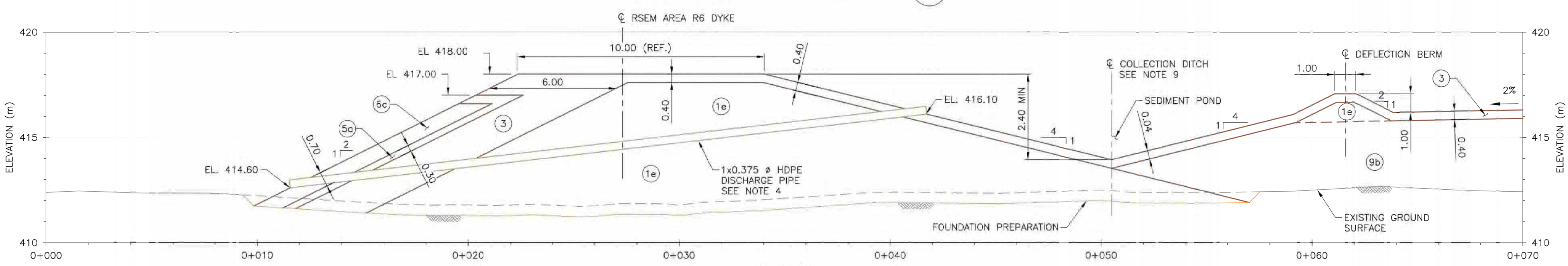

SECTION B
1:100

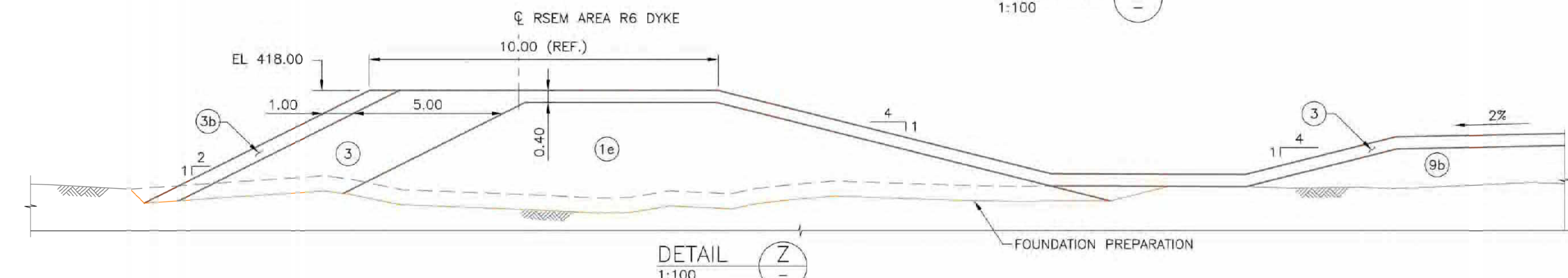

DETAIL Z
1:100

- NOTES:**
- EXISTING GROUND SURFACE DERIVED FROM 2006 LIDAR SURVEY.
 - DRAWING SHALL BE READ IN CONJUNCTION WITH REFERENCE CONCEPT REPORT.
 - SOUTH BANK ROAD, RIGHT BANK DRAINAGE TUNNEL ROAD AND CONSTRUCTION AREA ARE NOT SHOWN.
 - DETAILS OF DISCHARGE FROM SEDIMENT POND SHALL BE DETERMINED DURING DETAIL DESIGN.
 - EMERGENCY SPILLWAY SHALL BE DESIGNED TO SUIT CONSTRUCTION ACTIVITY.
 - TAILRACE, RCC BUTTRESS AND CORE TRENCH EXCAVATION DEWATERING PIPELINE ALIGNMENT SHALL BE FIELD FITTED TO SUIT CONSTRUCTION ACTIVITY.
 - BACKFILL COLLECTION DITCH AND REMOVE DEFLECTION BERM AT THE END OF THE CONSTRUCTION PERIOD. FINISHED SURFACE SHALL PROVIDE POSITIVE GRADE SUCH THAT PONDING DOES NOT OCCUR BETWEEN RSEM AND DYKE.

- LEGEND:**
- EXTENT OF SEDIMENT POND AREA
 - 1e IMPERVIOUS FILL
 - 3 COMPACTED GRANULAR MATERIAL
 - 3b SELECT COARSE GRANULAR MATERIAL
 - 5a RIPRAP BEDDING
 - 6c PERMANENT RIPRAP
 - 9b NPAG RSEM
 - RSEM RELOCATED SURPLUS EXCAVATED MATERIAL
 - NPAG NON-POTENTIALLY ACID GENERATING
 - RUNOFF FLOW DIRECTION

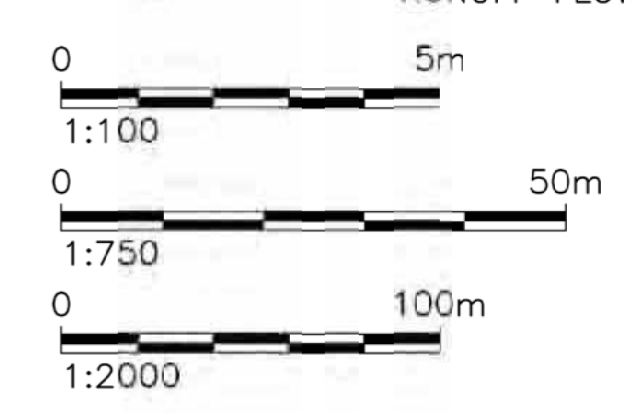

ISSUED FOR DATA ROOM

NOT FOR CONSTRUCTION

ALL DIMENSIONS ARE IN METRES UNLESS NOTED OTHERWISE

		<p>INTEGRATED ENGINEERING TEAM</p>	
<p>DSGN MJ. PIGGOTT</p> <p>INDEP CHK H. MCLEOD</p> <p>DFTG LH</p> <p>DFTG CHK MJP</p> <p>INSP BM</p> <p>CIV STR MECH GEO ELEC</p>	<p>DATE 25 NOV 2014</p> <p>DIST -</p> <p>DWG NO 1016-C11-00818</p>	<p>SITE C CLEAN ENERGY PROJECT</p> <p>DATA ROOM</p> <p>RSEM AREA R6</p> <p>REFERENCE CONCEPT</p> <p>PLAN, SECTIONS AND DETAIL</p> <p>WATER MANAGEMENT</p>	
<p>REV G. STEVENSON</p> <p>ACPT J.NUNN A.HANNA A.WATSON</p>	<p>DATE 25 NOV 2014</p> <p>DIST -</p> <p>DWG NO 1016-C11-00818</p>	<p>SIZE A0</p> <p>R 0</p>	<p>NOT TO BE REPRODUCED WITHOUT THE PERMISSION OF BC HYDRO</p>

C:\Users\mca\Documents\Projects\18_RSEM\18_RSEM-ME_RSEM\100_Drawing\21_LDR\1016-C11-00818_R00.dwg
 17/11/2014 5:54 PM
 BCI-Site C Project - Stage 3B\18_RSEM-ME_RSEM\100_Drawing\21_LDR\1016-C11-00818_R00.dwg

REF#	DRAWING NUMBER	TITLE	REF#	DRAWING NUMBER	TITLE	NO	REMARKS	DATE	DESIGNED	INDEP CHK	DFTG	DFTG CHK	INSP	REV	ACPT
REFERENCE DRAWINGS			REFERENCE DRAWINGS												
REVISIONS															

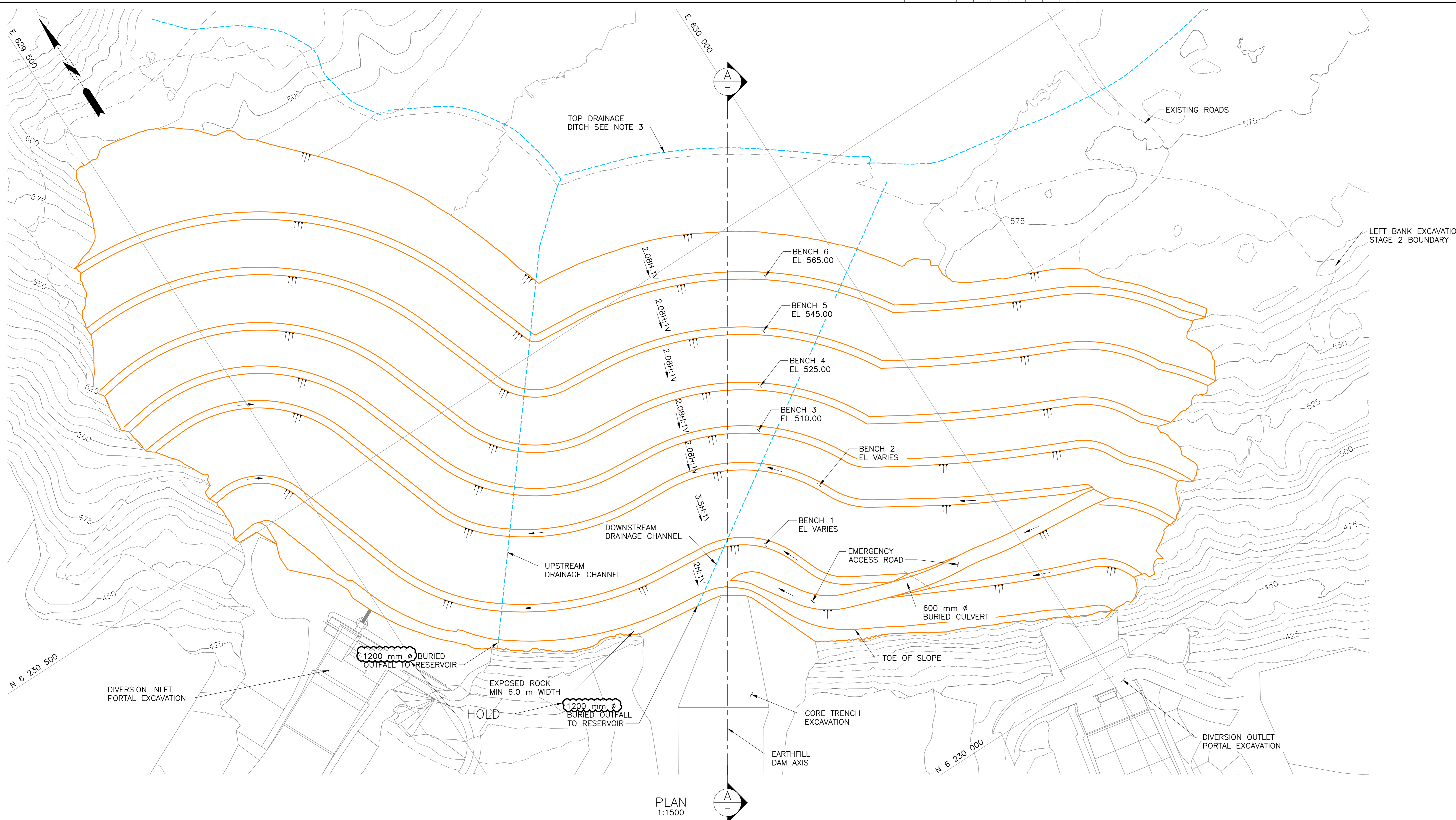

PLAN
1:1500

- NOTES :
- FOR LEFT BANK EXCAVATION GENERAL NOTES SEE DRAWING 1020-C18-00406.
 - EXISTING GROUND SURFACE DERIVED FROM THE 2006 LIDAR SURVEY.
 - BEFORE EXCAVATION OF STAGE 1 SLOPE, A DITCH SHALL BE CONSTRUCTED AT THE TOP OF THE STAGE 2 LEFT BANK EXCAVATION TO DIVERT RUN OFF AWAY FROM THE EXCAVATION.
 - CONTRACTOR SHALL BE RESPONSIBLE FOR PROVIDING ACCESS TO SLOPE. CONTRACTOR RESPONSIBLE FOR DRAINAGE AND RUNOFF MANAGEMENT, INCLUDING CONSTRUCTION OF DRAINAGE MEASURES ON BENCH 2 AND BELOW, AS SHOWN ON DRAWING 1020-C18-00406.
 - ABOVE BENCH 2, STAGE 1 TEMPORARY EXCAVATION SLOPES TO BE CONSTRUCTED TO 2.4H:1V OVERALL OR FLATTER.
 - ON AND BELOW BENCH 2, DRAINAGE DETAILS SHOWN ON DRAWING 1020-C18-00406 SHALL BE CONSTRUCTED AS PART OF THE STAGE 1 EXCAVATION.
 - THE ASSUMED BEDROCK SURFACE HAS BEEN GENERATED FROM THE INTERPRETATION OF AVAILABLE INVESTIGATION DATA AND IS THEREFORE APPROXIMATE.
 - EXCAVATION BY OTHERS WILL REMOVE OVERBURDEN FROM TOP OF LEFT BANK SLOPE, EXCAVATION SHOWN FOR APPROXIMATELY 2 MILLION m³ VOLUME.
 - SLOPE BELOW BENCH 2 SHALL BE REVEGETATED AFTER BEING EXCAVATED TO FINAL GRADE. REVEGETATION TYPE 1a SHALL BE USED.

- LEGEND :
- MH MANHOLE
 - DRAINAGE FLOW DIRECTION
 - DRAINAGE DITCH OR CHANNEL
 - CULVERT OR PIPE

BC Hydro CONTRACT NO. REF 520938
ISSUED FOR CONSTRUCTION
 BY: R. PEEVER HYDRO'S REPRESENTATIVE DATE: 12JAN2016

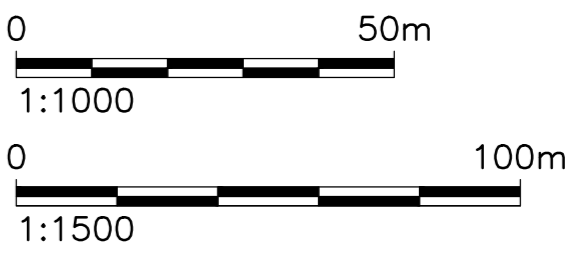

ALL DIMENSIONS ARE IN METRES UNLESS NOTED OTHERWISE



BC Hydro
 CLEAN ENERGY PROJECT - SITE C
 RESERVOIR - LEFT BANK EXCAVATION
 EXCAVATION AND DRAINAGE - STAGE 1
 PLAN AND SECTION

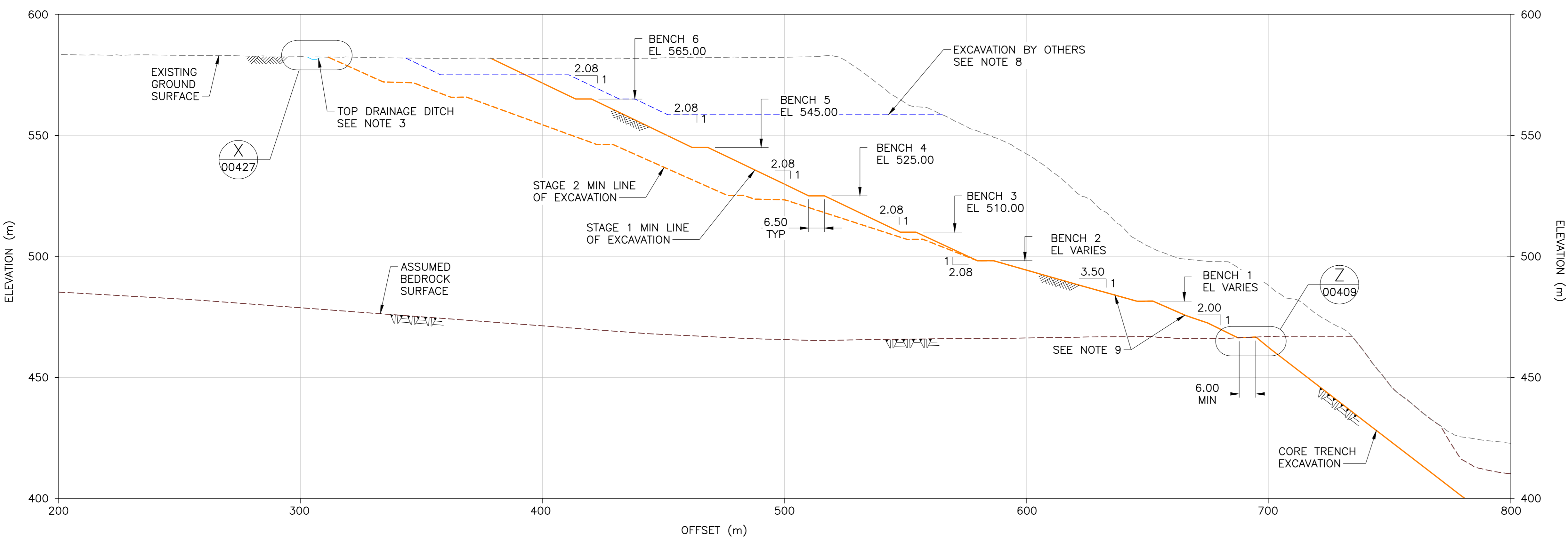

SECTION
1:1000

SITE CLEAN ENERGY PROJECT	
DSGN	S. BIRCH
INDEP CHK	G. HANNA
DFTG	AKL
DFTG CHK	PKL
INSP	RW
REV	CIV STR MECH GEO ELEC
ACPT	G. STEVENSON
ACPT	J. NUNN A. WATSON

ORIGINAL SEALED BY
 S. M. BIRCH
 11 DEC 2015
 P.ENG.
 APEGBC

REF#	DRAWING NUMBER	TITLE	REF#	DRAWING NUMBER	TITLE	NO	REMARKS	DATE	DESIGNED	INDEP CHK	DFTG	DFTG CHK	INSP CIV	INSP STR	INSP MECH	INSP GEO	INSP ELEC	REV	ACPT	DATE	DIST	DWG NO	SIZE	R
		REFERENCE DRAWINGS			REFERENCE DRAWINGS															11DEC2015		1020-C18-00407	A0	0

I:\21_DRAWING\09_CONSTRUCTION_DESIGN\MCA\1020-C18-00407.dwg
 CHAN, PETER
 12/27/2015 5:20 PM

Appendix J Erosion and Sediment Control Program

Erosion and Sediment Control Program (ESCP) - June 2017

All information contained herein is provided as guidance for the enhanced site-wide Erosion and Sediment Control Program (ESCP), in accordance with the commitments described in the October 18, 2016 letter to the BC Environmental Assessment Office titled: Next Steps for the Erosion and Sediment Control Plan on the Site C Project.

Introduction

The Contractor is responsible for the successful execution of erosion prevention and sediment control measures on the Site C Project. The risk of improper ESC measures leading to a decrease in water quality in the Peace River and adjacent waterbodies has been identified as a key risk item for the Project. Contractor's site and activity specific EPPs/ESC plans must therefore be crafted in a manner which meets the requirements and procedures spelled out in this document, along with those referenced within namely Appendix I of the CEMP. Failure to adhere to such measures to prevent erosion, manage sediment transport and control runoff will result in a non-conformance and potentially a non-compliance. Effective and properly installed erosion and sediment control measures is always the requirement

This guidance document and its associated attachments provide information on roles and responsibilities along with guidance for planning, installation, inspection and maintenance of ESC measures. It also described the reporting expectations and tools that are required to be used to track and document adherence to and conformance with the ESC Program.

Erosion and Sediment Control Measures

The Site C Project's environmental specifications and performance objectives are contained within the rev 4 CEMP which is the overarching guidance document for environmental performance on the project. Industry leading best management practices and general ESC measures are contained within section 4.4 of this plan and are meant to inform site and activity specific Environmental Protection Plan(s) that are to be drafted by the Contractor to reflect the activity and location specific risks presented by a discrete work package or work area.

Stemming from a non-compliance and subsequent EAO Order, BC Hydro developed a more detailed 'Water Management, Erosion and Sediment Control Plan – July 8 2016' (WMESCP), which includes detailed prescriptions and methodologies to inform Contractor's EPPs. The plan is detailed and robust and considers variables like: water quality criteria, climate, design rainfall, run-off coefficients and erosion potential to inform the Contractor's QP-CPESC on use of appropriate mitigation measures.

The WMESCP is a detailed guidance document that should be used to inform decision making and ESC prescription selection. Moreover, the WMESCP provides guidance on where and how to use a variety of mitigation measures and provides the Contractor with 'advantages' and 'challenges' each measure faces, to help support site and activity specific measure selection.

Roles and Responsibilities

Qualified Professional and Certified Professional in Erosion and Sediment Control (QP-CPESC)

The EAO Order requires that all ESC measures be designed, implemented, monitored and maintained by an individual that is both a Qualified Professional and a CPESC. The exact definition is contained below:

“Qualified Professional” means an applied scientist or technologist specializing in an applied science or technology applicable to erosion and sediment control planning, design and implementation; and who is registered with the appropriate professional organization in the Province of British Columbia (BC); is acting under the organization’s code of ethics and is subject to disciplinary action by that organization; **and** who is an Accredited Professional with the Erosion and Sediment Control Association of Canada.

The QP-CPESC oversees the Contractor’s planning, installation, inspection and maintenance of all ESC measures and corresponding reporting in accordance with Appendix I of BC Hydro’s CEMP rev 4.

The QP-CPESC has primary responsibility for the quality assurance and functionality of the ESC measures being implemented and shall oversee installation of such measures and adhere to a monitoring program that ensures mitigation measures remain effective over the course of their installation and to identify maintenance requirements as they arise. The QP-CPESC shall sign-off on all installations and on the ongoing monitoring efforts and subsequent reporting.

A key role for the QP-CPESC is for oversight and verification of the quality of installations. This requires that the QP is active in day to day supervision of all ESC installations and that BMPs, manufacturer’s specifications and function are implemented and verified through this program. Installations must be inspected and signed off as meeting these quality expectations before they are considered ‘installed’ within the program. ***By attesting that quality and function are acceptable, the QP CPESC is verifying the quality of ESC works in the context of professional reliance, which is the practice of accepting and relying upon the decisions and advice of qualified professionals who accept responsibility and can be held accountable for the decisions they make and the advice that they give.***

The QP-CPESC will:

- Develop ESC work plans, including site-specific prescriptions and sketches (Field Maps);
- Communicate prescriptions to work crews and provide supervision;
- Coordinate prescription development and quality sign-off with other SMEs, such as P.Eng, hydrologists and P.Geo’s as appropriate;
- Supervise the installation of the ESC measures and document the completion of ESC work plan;
- Establish an appropriate ongoing inspection and re-inspection frequency for each ESC site that is commensurate with the sites risks and failure modes
- Supervise the ongoing inspection and resulting maintenance of ESC measures;
- Revise ESC work plans as needed;
- Ensure that all ESC sites are ranked and categorized in terms of risk and implementation status;
- Ensure that ESC installations are scheduled for re-inspection;
- Ensure that ESC installations are inspected after any significant rainfall (12m in 24hrs);
- Sign off on prescription installation, ESC re-inspection and will be responsible for assigning risk categories and current status of ESC sites;

- Verify that the quality of workmanship and installation meets ESC BMPs, as described in the WMESC plan; and,
- Report on the ESCP on a weekly basis (Saturday), to BCH using the ESC Tracker table which shall be provided to all Contractors.

Environmental Monitors/Coordinators will:

- Re-inspect ESC locations using the QP-CPESC inspection templates;
- Complete the Site C ESC Inspection Form for each ESC inspection/re-inspection;
- Provide an observational, recording, reporting function in support of the QP-CPESC; and,
- Communicate with work crews and construction supervision on ESC matters.

BCH ESCP Documentation

As part of the ESCP, BC Hydro maintains an active list of all current and historic ESC locations associated with the Site C Project. This database relies upon the Contractor's submittals which inform the data base and provide BC Hydro with a snapshot of current ESC conditions on Site. To fulfill these objectives, BC Hydro has adopted an ESC Tracking Tool. The following sections detail how the ESC Tracking tool and associated documents are to be utilized to fulfill the requirements set by the EAO.

A combination of inspection forms, ESC field maps, photos and the active list are used to document compliance with the ESCP and to track changes to specific ESC mitigation measures at specific locations over time, thereby reflecting the highly dynamic nature of ESC mitigation measures on a major Project that involves significant earthworks adjacent to a major river.

In order to facilitate on-going monitoring and reporting, BC Hydro provides guidance, tools, and sometimes direction to the Contractor to assist their efforts to monitor locations within their work areas and improve ESC management.

A package of program documents is transmitted to the Contractor every Tuesday and are current to the previous reporting period ending on Saturday. Transmitted documents include:

- Weekly ESC Report (Memo)
- ESC Inspection Form
- Maps of the Contractors Work Areas and associated ESC Locations
- Google Earth file of all ESC Locations

ESC Inspection Form

The ESC inspection form is presented in spreadsheet form (.xlsx) and contains two tabs of information.

- 1.) The "All Locations" tab includes all historic and current information pertaining to ESC Locations within the Contractor's area of responsibility.
- 2.) The "Inspection Form" tab includes a line item for all active ESC locations with information pertaining to the last inspection.

The purpose of the ESC inspection form is to enable the Contractor to manage all the active ESC locations within their work zones and provide a streamlined approach to documenting and submitting inspections to BC Hydro.

Within the ESC Inspection form, cells highlighted in red are mandatory content cells and signal to the Contractor that immediate attention is required. In reference to the “All Locations” tab this information will pertain to ESC prescription completion dates, qualified professional (QP-CPESC) approvals, implementation inspector and inspection dates. In reference to the “Inspection Form” tab this information will relate to inspections that are overdue or due within this current reporting period.

Guidance on how to properly complete the ESC Inspection form is provided in Attachment 1.

ESCP Installation, Inspection and Maintenance

Under the ESCP, ESC mitigation measures shall follow a continuous improvement approach whereby ESC prescriptions are planned, installed, inspected and maintained. This approach reflects dynamic and ever changing nature of construction, specifically earthworks which inherently seeks to alter existing ground conditions continually until final grade and revegetation is achieved. Reflecting this dynamic nature, the ESCP requires that the status of ESC measures be categorized and managed to the following definitions:

- Prescription
- Installation
- Maintain
- Issue - Maintain
- Closed

These categories shall be used and referenced within the ESC Tracker, a tool that is used to track the on-going success of ESC measures at specific locations on the Project and which is described in greater detail in subsequent sections of this document. ESC Tracker categories are described in detail below.

Issue Prescription

The first stage in process of continual improvement is to initially have the QP-CPESC to identify and bound the active work area in which they are planning to implement ESC measures. A work-front level ESC Plan could be at the micro-catchment level and may have numerous individual ESC treatments prescribed, reflecting the specific intrusive activities (trenching, open excavation, sloping etc) planned for the area. The QP-CPESC will then prepare a prescription that identifies and describes the objectives, the surrounding environmental values which may be at risk, and will recommend materials, methods, configuration and timing of ESC Measures. The QP-CPESC is required to consult the WMESCP when developing a site or activity specific ESC plan.

A field map suitable for crew instruction and documentation is then produced to inform installation. The ESC work plan must be signed-off by the QP-CPESC, who must also establish an ‘installation target date’, which is also used to inform a re-inspection trigger date. Subsequent failure to meet the target implementation date will be treated as an environmental non-conformance, unless conditions at the site have changed and the QP-ESC has modified the prescription.

At this point, the ESC location and prescriptions initiate the use of the ESC Tracker, whereby a new ESC location is created in the ESC Tracker tool, so that it's adherence to this plan can be tracked and recorded over time. See below for further instruction on the use and maintenance of the ESC Tracker.

Installation

After the prescription phase, the next step is the actual installation of the ESC measures. During installation, the QP-CPESC must verify and document that the material quality and workmanship of the ESC installation meets the intent of the ESC Plan and once complete, are functioning as per the intent. Inspections may take place mid-way through installation, in which case the status of the location is changed to 'installation in progress' using the ESC Tracker spreadsheet. When an installation is satisfactorily installed and accepted by the QP-CPESC, the status within the ESC Tracker will be changed to 'maintenance'. Without the quality verification, the status cannot be changed to 'maintain, and may require reversion to 'Issue-Prescription', if appropriate.

During this phase, the QP-CPESC is required to be active in day-to-day supervision of all ESC installations and that BMPs, manufacturer's specifications and function are implemented and verified through this program. Installations must be inspected and signed off as meeting these quality expectations before they are considered 'installed' within the program. By attesting to the quality and functionality of the ESC measures, the QP-CPESC is verifying the quality of the ESC works in the context of professional reliance, which is the practice of accepting and relying upon the decisions and advice of qualified professionals who accept responsibility and can be held accountable for the decisions they make and the advice that they give.

Maintain

Once ESC measures are installed correctly and are functioning as intended, they are required to be routinely inspected at a frequency that is acceptable to the QP-CPESC. Normally the return period will be no more than two weeks, during normal weather conditions and immediately following severe precipitation events. All inspections and any resulting observations shall be recorded on the ESC Inspection form and shall be captured in the ESC Tracker table.

Issue - Maintain

If, during re-inspections of ESC installations under the maintain status, the QP-CPESC inspector identifies deficiencies, or wear and tear that requires maintenance, the status of this location within the ESC Tracker table shall be changed to 'Issue – Maintain', and a new prescription will be created and communicated to work crews for implementation. This phase is an important stage for ensuring that ongoing functionality of the ESC installations and reflects the ESCP's goal for continuous improvement at all ESC locations.

Closed

ESC locations are closed for the purposes of the tracking tool once any of the following conditions are met:

- Ground conditions change such that the prescription is no longer relevant. This could be a situation where excavations, configuration or elevation levels change to the extent that existing temporary ESC measures are no longer valid;
- The QP-ESC uses his judgement to close an ESC location and revise the prescriptions into a new prescription. This could be the case when an ESC location has multiple prescriptions and a portion are completed and where the remaining prescriptions are revised to reflect better information or changing conditions; and,
- The location is revegetated, stable and no longer subject to construction activities.

Monitoring and Reporting Objectives

Weekly ESCP reports, due every Saturday, will be submitted using the ESC Tracker (Attachment 1) that the Contractor's QP-CPESC is accountable for.

The Contractor's QP-CPESC and Environmental Monitors shall routinely:

- Conduct ESC-based inspections and re-inspections of work areas, utilizing the Site C ESC Inspection Form (attached), and the ESC Tracker spreadsheet;
- Categorize issue status (new or revised prescriptions, installations in progress, maintenance prescription or functioning);
- Characterize risk classes;
- Schedule follow up inspections and implementation of 'Target Completion Dates' for ESC measures;
- Inspect all ESC installations at a minimum frequency of every two weeks, unless otherwise prescribed by the QP-CPESC, or after a significant rain event (defined as >12 mm precipitation within any 24 hour period, or precipitation or snowmelt on wet or thawing soils [CEMP Appendix I S.2.2.3]);
- Maintain ESC photos and upload photos every Saturday which shall be the weekly reporting deadline;
- Prepare ESC memos, field instructions/sketches where required for submission to BC Hydro and Contractor management;

On a daily basis, complete the following:

- ESC inspections and oversight as required;
- Complete 'Site C ESC Inspection Forms'
- Include environmental and ESC content at tailboard meetings;
- Daily ESC Tracker memo updates as required; and,
- Notification to BC Hydro of any ESC Sites which are not conforming with the relevant prescription.

On a weekly basis, delivered to BC Hydro every Saturday, the following:

- Updated ESC Tracker in electronic (Excel spreadsheet) format;
 - Updated observations of site conditions using the ESC Inspection Form
 - Any revised prescriptions
 - Verification of correct installations and workmanship; and,
 - A rationale for a change in target due dates, if any; and,
 - Any communication documents, memorandums or letters on prescribed ESC measures or completed works
- Updated photos;
- Response and documentation of non-conforming locations within the Contractor's work area along with corrective actions to address such deficiencies.

Weekly deliverables are to be sent to:

SiteCENV@bchydro.com

The Contractor is also required to submit the above information on a weekly basis (every Saturday) to the appropriate Supply Chain Workspace (See Attachment 2) with notification sent to the appropriate document controller.

Response to Non-Conformance ESC Locations

In the event that a work site is observed as non-conforming with the applicable ESC plan prescriptions, such as poor quality of installation, failure of the ESC measures for some reason, or by missing a target due date, the Contractor will be required to escalate the condition to an internal non-compliance. The specifics of the non-compliance will form part of the weekly Saturday submittal. The weekly report content shall highlight the deficiency within the ESC Tracker, supplemented by copies or details of the internal communications if appropriate. Details should include any and all potential risks to near-by watercourses, observed non-compliances stemming from turbid run-off impacting adjacent watercourses, and the proposed corrective actions to address any ESC deficiency.

Additional guidance on how to complete the reporting described above is provided in Attachment 1 for your consideration.

Guidance on Completion ESCP Documents

Completion of Inspection Forms and the ESC Tracker

The ESC inspection form is presented in spreadsheet form (.xlsx) and contains two tabs. The “**All Locations**” tab includes all historic and current information pertaining to ESC Locations within the Contractor’s responsibility. The “**Inspection Form**” tab includes a line item for all active ESC locations with information pertaining to the last inspection.

Provided below is a reference for how to properly complete the weekly inspection forms prior to returning to BC Hydro. Please review this information and use it as a reference for each weekly submittal. Below is a step-by-step instruction for how to complete an Inspection Form:

- 1.) Open latest version of the inspection form file;
- 2.) Create new location or find existing location;
- 3.) Provide updated inspection comments and change ESC location status as required;
Verify as the CP-CPESC that the quality and function of ESC structures are acceptable;
- 4.) Enter the date of installation completion, if applicable; and,
- 5.) Close ESC location if appropriate.

“Inspection Form” Definitions

Column Ref.	Column Name	Editable/ Required?	Description
1	Zone	No	<ul style="list-style-type: none"> Work Zone acronym reference. Unique 4 letter acronym for each work zone onsite. Pre-populated. Do no update/change this column.
2	Previous Inspection Date	No	<ul style="list-style-type: none"> Last date an inspection was completed for that particular location. Pre-populated. Do no update/change this column.
3	Inspector	Yes	<ul style="list-style-type: none"> Name of inspector onsite completing the current inspection on that specific location. Left blank if no inspection complete at that location that week.
4	Inspection Date	Yes	<ul style="list-style-type: none"> Represents the date the inspector visited the site and collected site observations. If visited multiple times a week use the most recent date and most recent observations.
5	Next ESC ID No.	No	<ul style="list-style-type: none"> Unique ESC ID for each location made up of the Zone Acronym (XXXX.), Location Number (###.), and Inspection Number (##). Pre-populated. Do no update/change this column.
6	Work Area	No	<ul style="list-style-type: none"> Work Areas are pre-defined and chosen from a list. Please choose the most appropriate work area for the ESC Location. If an adequate location does not exist please leave blank and communicate to BC Hydro (via email or weekly submission) what Work Area should be added.
7	Location Description	Yes	<ul style="list-style-type: none"> Detailed description of the location of that specific ESC Location. Can include station numbers for roads/channels or relative descriptive location based on surrounding features.
8	Previous Inspection Observations	No	<ul style="list-style-type: none"> Observations of the ESC location from the past inspection are provided as a reference; these observations can be used in the formulation of the current week’s observations and can be used to determine change in conditions.
9	Current Inspection Observations	Yes	<ul style="list-style-type: none"> Current observations should reflect the current conditions onsite (if no changes have occurred then copying the previous weeks observations is acceptable) Observations should be descriptive and as qualitative as possible to show changes in a sites condition over multiple inspections.
10	Previous Status	No	<ul style="list-style-type: none"> Previous status of the last inspection; this column is locked and no input is required. ESC Location status can either be Maintain, Issue (Prescription), Issue (Maintain) or Installation. Details on these designations is provided below.
11	Current Status	Yes	<ul style="list-style-type: none"> Status of the current inspection as determined by the inspector; can be edited. ESC Location status can either be Maintain, Issue (Prescription), Issue (Maintain) or Installation. Details on these designations is provided below.
12	Risk Level	No	<ul style="list-style-type: none"> Pre-set risk level of each specific ESC Location.
13	Prescription Short Description	Yes	<ul style="list-style-type: none"> Only required if location status is Issue (Prescription), Issue (Maintain), or Installation. If Maintain status leave blank (formatting will automatically grey out the cells). Short description of required works to be completed by contractor to remedy ESC issues at location.
14	Target Completion Date	Yes	<ul style="list-style-type: none"> Target completion date only require if location status is Issue (Prescription), Issue (Maintain), or Installation. If Maintain status leave blank or enter “N/A” (formatting will automatically grey out the cells). Represents a practical date in which prescribed ESC works will be completed by the contractor.
15	ESC Contractor	Yes	<ul style="list-style-type: none"> Name of the contractor responsible for ongoing inspections and ESC prescriptions. If you do not believe the site inspected belong under your responsibility you can change this value or leave it blank; if so this must be communicated to BC Hydro via email or weekly ESCPP submission.
16	QP Review	Yes	<ul style="list-style-type: none"> If the inspector is the ESC QP and no other QP review was require they may enter their name. If the inspector is not an ESC QP the form must be reviewed by an ESC QP and their name must be entered.
17	ESC Contractor Prescription Memo Reference	Yes (if not greyed out)	<ul style="list-style-type: none"> Any prescriptions to address ESC installations or issues should be corroborated with a reference to the ESC contractor’s prescription memo; This memo shall be submitted with the weekly transmittal of the ESC inspection form and should document any detailed prescriptions necessary to address outstanding ESC issues within the contractors work areas.

Column Ref.	Column Name	Editable/ Required?	Description
18	Quality and Function of ESC Works Approved? (Y, N, N/A)	Yes	<ul style="list-style-type: none"> By assigning a “Yes”, the QP ESC is verifying the quality of ESC works in the context of professional reliance, which is the practice of accepting and relying upon the decisions and advice of qualified professionals who accept responsibility and can be held accountable for the decisions they make and the advice that they give. This information is required for inspections under all conditions - ‘Issue (Prescription), Issue (Maintain), Installation and Maintain’ status; If the works have been completed to an acceptable standard, then the QP ESC shall select ‘Yes’; If the works have been completed but not to an acceptable standard, then the QP ESC shall select ‘No’, in which case the prescription cannot be closed; If during a maintenance inspection, the QP ESC observes issues requiring repairs or maintenance, and cannot accept the ongoing quality or function of the installation, then the QP ESC shall select ‘No’. The status of the ESC location will be reverted to ‘Issue (Maintain)’, with a new prescription and a revised target due date; If the inspection takes place in the installation process, to provide this verification, then ‘N/A’ may be selected; If the works have been completed, but the QP ESC is not able to sign off on an engineered design portion of the works, they may select ‘N/A’.
19	ESC Measures Implemented? (Y, N, N/A)	Yes (if not greyed out)	<ul style="list-style-type: none"> Any ESC locations in installation, maintenance or with an outstanding issue – ‘Issue (Prescription), Issue (Maintain), Maintain, or Installation’ require this column to be completed; If implementations of ESC works are in progress, then ‘No’ should be selected; If the implementation of ESC works are completed, then ‘Yes’ should be selected; If no ESC works are prescribed and the location is in ‘Maintain’ status then ‘N/A’ should be selected.
20	Contractor Actual Completion Date	Yes (if not greyed out)	<ul style="list-style-type: none"> This column is required when prescribed ESC measures have been completed (i.e. previous inspection status is Issue (Prescription), Issue (Maintain), or Installation; while current status is Maintain or Closed); the form will automatically grey the section out if this information is not required. This column should reflect the date the ESC contractor completed the construction of the prescribed ESC measures (this may not be the same as the inspection date).
21	QP Comments on Implementation	Yes (if not greyed out)	<ul style="list-style-type: none"> This column is required when prescribed ESC measures have been completed (i.e. previous inspection status is Issue (Prescription), Issue (Maintain), or Installation; while current status is Maintain or Closed); the form will automatically grey the section out if this information is not required. This column is intended to provide space for comment on the installation of any ESC measures including notes on quality of installation, concerns on design or functionality, etc.

Inspection Form

1	2	3	4	5	6	7	8	9	10	11
Zone	Previous Inspection Date	Inspector	Inspection Date	Next ESC ID No.	Work Area	Location Description	Previous Inspection Observations	Current Inspection Observations	Previous Status	Current Status
ATCO	10-May-17			ATCO002 10	ATCO Workers Accommodation	Row 9: Parking Lot Slope drain to Workers Accommodation, North Drainage Channel	Patch/seed has been recommended to reestablish slope drains. Work will be completed when slopes are dry to prevent compaction and damage to the slope by equipment.		Issue (Prescription)	Issue (Prescription)
ATCO	10-May-17			ATCO003 10	ATCO Workers Accommodation	Slopes north of Row 9: Parking Lot slope higher Accommodation, North Drainage Channel	Vegetation starting to grow. Will be monitored for coverage and of Me.		Issue (Maintain)	Issue (Maintain)
ATCO	10-Apr-17			ATCO004 08	ATCO Workers Accommodation	Slopes along west boundary of Workers Accommodation.	Seed and mulch present on slope and some vegetation visible. Snow covered and frozen.		Maintain	Maintain
ATCO	10-Apr-17			ATCO005 08	ATCO Workers Accommodation	Slopes along east boundary of Workers Accommodation.	Seed and mulch present on slope but application is thin. Snow covered and frozen.		Maintain	Maintain
ATCO	10-Apr-17			ATCO007 08	ATCO Workers Accommodation	Slopes along east boundary of Workers Accommodation.	Several seed and mulch observed on slope. Snow covered and frozen.		Maintain	Maintain

Zone	Physical Inspection Date	Inspection	Inspection Date	Next ESC ID No.	Risk Level	Prescription Short Description	Target Completion Date for Installation of Prescription	ESC Constraints	IP Review	ESC Compliance Prescription Memo Reference	Quality and Function of ESC Works Approved (Y, N, NA)	ESC Measures Implemented? (Y, N, NA)	Compliance Actual Completion Date	IP Comments on Implementation
PTCD	18-Mar-17			PTCD-0010	Low Risk	Control of erosion through the use of riprap-based control structures installed by the riprap contractor (RMC). Controls for erosion control to riprap work will be completed by the end of the riprap work. VMS will monitor riprap for any settlement. VMS will report to the contractor by the end of the riprap work.	1-Jun-17	ATSD						
PTCD	18-Mar-17			PTCD-0010	Low Risk	Monitor riprap growth, and implement measures for applying ESC measures to riprap (RMC).	1-Jun-17	ATSD						
PTCD	18-Mar-17			PTCD-0010	Low Risk	None	None	ATSD						
PTCD	18-Apr-17			PTCD-0010	Low Risk	None	None	ATSD						
PTCD	18-Apr-17			PTCD-0010	Low Risk	None	None	ATSD						

Status	Definition	Prescription / Target Date Required?
Closed	A location in which any previous ESC measures and/or controls have been removed and/or are no longer required.	No
Maintain	A location in which all ESC measures and/or controls in place are functioning effectively and no changes are required. Only ongoing inspection and maintenance of said measures/controls is required.	No
Issue (Maintain)	A location where the ESC measures and/or controls in place are deemed as adequate but are damaged, full and/or no functioning due to a maintenance issue. A prescription identifying the maintenance activities is required.	Yes
Issue (Prescription)	A location where the ESC measures and/or controls in place are deemed as not adequate for the location. A prescription identifying a change to the ESC measures and/or controls is required.	Yes
Installation	A location where planned ESC measures and/or controls has been planned (via an EPP) but are not currently in place. A prescription referring to the planned measures/control and installation date is required.	Yes

Starting New Locations

For each zone a new blank ESC ID line has been created within the “Inspection Form” tab and highlighted in blue (as seen below). The next available ESC ID No. has been pre-populated. To create a new location during an inspection please populate the line item as per the descriptions provided in this attachment.

To create more than one location please insert a line underneath the blue line and continue the numbering as per the above line items.

“All Locations” Tab

The “All Locations” tab includes all historic inspections for locations within the contractors work areas. This tab is meant as a reference for future inspection. No input is required on this tab as it is meant only as a reference.

Geo-referenced ESC Mapping



Contractors are required to include geo-referencing data in all their ESC prescription mapping to allow for use with application like Avenza Maps (<https://www.avenzamaps.com/>). This application will allow you to open a digital copy on a mobile platform for reference in the field.

If you do not have access to an application like Avenza Maps you can print the maps and use a hardcopy for reference in the field .

ESC and Google Earth Maps

A KML file is provided with the weekly package for use in Google Earth or Google Maps. The file contains all points within the Contractor work areas and the associated information such as observations, prescriptions, target completion dates etc.

This file can be opened on a mobile device within a Google Maps application and used in the field as a tool to locate and update ESC locations.

In Google Earth each location is represented by either a star  indicating the need to inspect this week, a square  indicating an inspection required within the next two weeks, and the circle  for all remaining locations. The colours indicate the status of the location, **RED** represents Issue (Prescription), **YELLOW** represents Issue (Maintain), **GREY** represents Installation, and **GREEN** represents fully functioning controls in Maintain status.

ESC Photos

A photo naming protocol (.xslm) is included to assist in the organization of ESC related photos and to meet the photo file naming convention of the ESCP. All photos must be geo-referenced and the file name must be representative of the ESC locations they represent. The complete file naming convention for ESC photos is defined below (e.g. SITE.001.01.01).

<i>XXXX</i>	<i>###</i>	<i>##</i>	<i>##</i>
<i>Zone Acronym</i>	<i>ESC Location Number</i>	<i>ESC Inspection Number</i>	<i>Photo Number</i>
<i>(SITE)</i>	<i>(001 – 999)</i>	<i>(01 – 99)</i>	<i>(01 – 99)</i>

All ESC photos must be uploaded by the Contractor to the BC Hydro Photo Lynx software every Saturday. This will make the photos available to BC Hydro for review. Direction on how to complete photo uploads in the Photo Lynx software is provided in Attachment 2.

Use of the PhotoTool V4.1

The PhotoTool can be used in conjunction with the Theodolite App to efficiently label any site photos. The PhotoTool V4.1 will read the label assigned in the field by the Theodolite application and automatically change the file name of your photos to match. Use the buttons and prompts within the tool to copy your photos to a 'Renamed' folder. A Google Earth export is also available within the tool to help validate the names and locations of the photos. (<http://hunter.pairsite.com/theodolite/>)

Transmittal of Documents through BC Hydro Supply Chain Workspace (SCW)



Appendix K Invasive Weed Mitigation and Adaptive Management Plan

SITE C INVASIVE WEED MITIGATION & ADAPTIVE MANAGEMENT PLAN



August 2020

This Invasive Weed Mitigation and Adaptive Management Plan has been reviewed and certified by the following professionals:

Certified by:

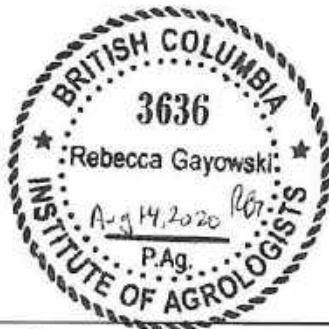

Rebecca Gayowski, PAg
Pathfinder Endeavours Ltd.

Verified by:

Rick Matthe, EP
Pathfinder Endeavours Ltd. Owner & Project Manager

Contents

- Revision History1
- Section 1: Introduction2
- Section 2: Objectives3
- Section 3: Plan Development3
 - Section 3.1: Review of Historical Data, Field Surveys, and Inventories4
 - Section 3.2: Exposed Land and Borrow Management Plan.....5
 - Section 3.3: Vehicle and Equipment Access5
- Section 4: Educate Work Force7
- Section 5: Implement Control and Mitigation.....8
 - Section 5.1: Herbicide Application8
 - Section 5.2: Mechanical Control.....9
 - Section 5.3: Rinse Station Mitigation 10
 - Section 5.4: Seasonal Mitigation 11
- Section 6: Implementation 12
- Section 7: Assess Effectiveness 13
- Section 8: Monitor & Enforce Processes 14
- Section 9: Reporting 15
- Section 10: Frequency of Program Activities 16
- Appendicesi
 - Appendix 1: Task List and Responsibilitiesii
 - Appendix 2: Classification Tables of Invasive Weed Species.....xi
 - Appendix 3: Field Formsxii

Revision History

Version	Date	Comments
Draft	April 13, 2017	Pathfinder draft document to Greg Scarborough
Rev 1	April 20, 2017	Revise to BC Hydro interpretation
Rev 2	April 21, 2017	PEL finalized and submitted to GS
Rev 3	June 8, 2017	PEL internal edits Added rare plants Added updated noxious weed list & priorities
Rev 4	July 21, 2017	Incorporate changes from GS and RR Add Table 2 and 3, renumber all other tables Add field forms to Appendix 5
Rev 5	July 26, 2017	Define QP-Invasives Incorporate changes from DM Remove species list, add links. Renumber appendix 5 to appendix 3
Rev 6	August 14, 2017	Incorporate changes from JL Add specific PMP numbers
Rev 7	August 14, 2020	Update PMP's in section 3.0 Update section 3.2 Update Section 9 Update Appendix 1 Update links and other miscellaneous changes Incorporate changes from MB

Section 1: Introduction

In response to the Order for Environmental Assessment Certificate E14-02 an Invasive Weed Mitigation and Adaptive Management Plan has been created. It satisfies the requirements of the Order to provide a plan for the prevention and management of invasive weed populations on all project areas of Site C.

<https://www.sitecproject.com/sites/default/files/Site-C-Section-34-Order-Invasives-March-2017.pdf>

As per the Order, this plan requires a number of activities that are to be implemented under the direction of a Qualified Professional who is an applied scientist or technologist specializing in agronomy; who has demonstrable expertise in the assessment and management of invasive weeds, including the assessment of effects and development of mitigation to prevent or minimise effects to agriculture and ecosystems; and who is registered with the appropriate professional organization in the Province of British Columbia (BC), and is acting under that organization's code of ethics and is subject to disciplinary action by that organization. This person is herein referred to as the QP-Invasives.

BC Hydro was mandated to create and implement an effective plan to address the current and potential future invasive and noxious weed populations located on the Site C project lands. In addition, it will provide mitigation measures to prevent cross contamination of properties within the various Site C project areas and beyond its boundaries. This will be achieved through numerous mitigation options that have been developed specifically for Site C and also from industry best management practices. The entire program will be based on an early detection and rapid response process to ensure that invasive weed seed beds are not established. Planning and monitoring will play a large role in ensuring the success of the plan. Educating on-site personnel and contractors will contribute to accomplishing the objectives set out within this plan. This plan recommends the processes that can be used across the changing activities that will take place in the construction of this project. All mitigation and control measures will be conducted to the satisfaction of a QP-Invasive and under all applicable provincial and federal legislation and under the applicable Pest Management Plan (PMP).

Section 2: Objectives

The following chart provides the objectives in an order that will best suit The Plan. These seven objectives will allow for the effective management of existing and avoid proliferation of noxious and invasive weeds on The Project lands. It is an adaptive plan that will identify, prevent, treat, and monitor invasive species throughout the construction phases of The Project.

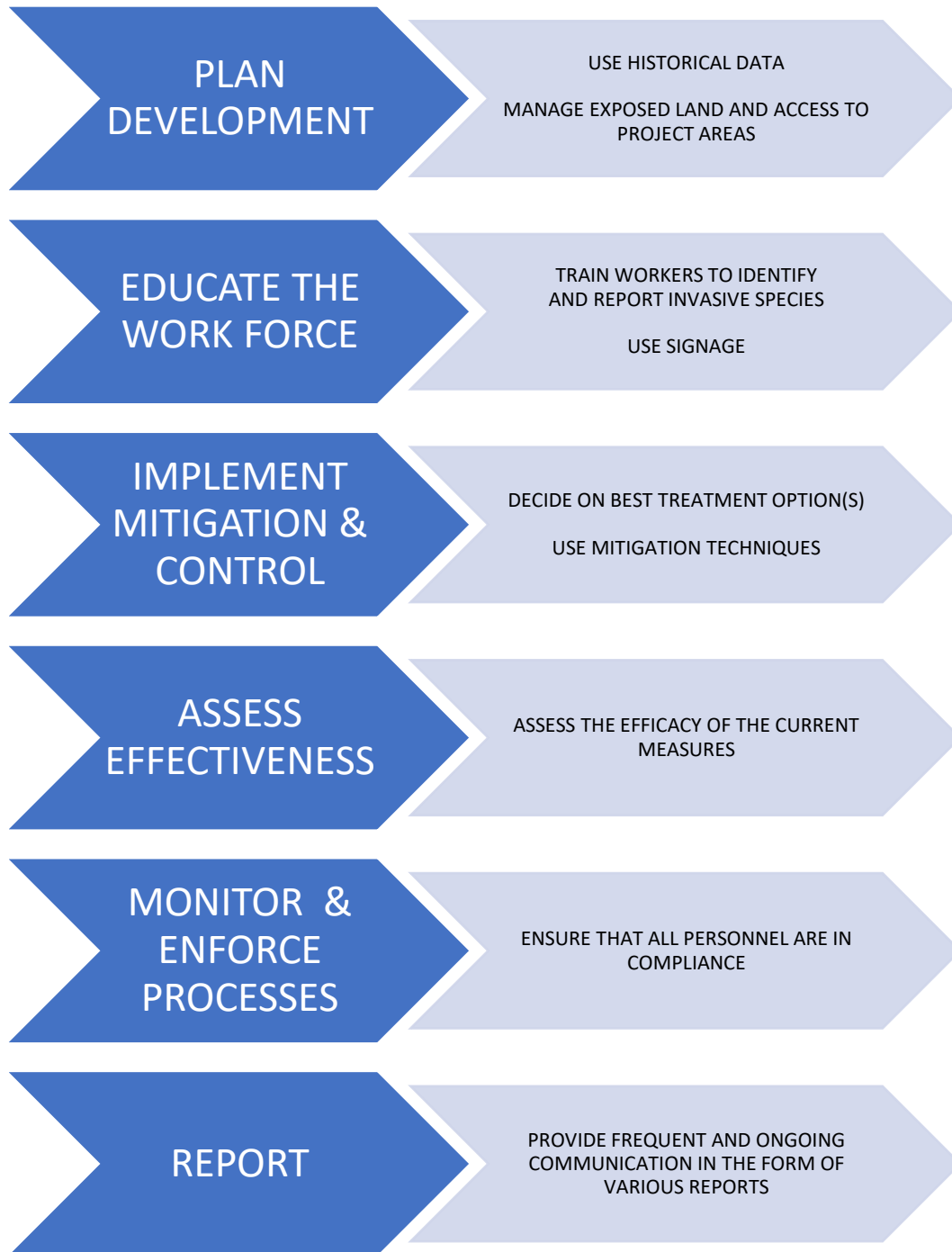

All objectives must be undertaken in compliance with applicable federal and provincial regulations.

Section 3: Plan Development

During the development of plans, the QP-Invasives must ensure the appropriate Pest Management Plan (PMP) is used in accordance with section 58 of the Ministry of Environment’s Integrated Pest Management Regulation (IPMR) for each particular work area:

For the dam site area and quarries:

- [Integrated Vegetation Management Plan for Control of Vegetation at BC Hydro Facilities # 105-0983-16/21](#)

For transmission line work:

- [Integrated Vegetation Management Plan for BC Hydro Transmission and Distribution Power Line Corridors # 105-0982-16/21](#)

For highway realignment:

- [Invasive Plant Pest Management Plan for Provincial Public \(Crown\) lands in Central and Northern British Columbia # 402-0680-20/25](#)

Or any other applicable PMP, as deemed appropriate by the QP-Invasives.

Section 3.1: Review of Historical Data, Field Surveys, and Inventories

The following procedures are necessary to determine the distribution and extent of invasive weed populations over the entire Site C footprint.

- **Historical information** – Review the invasive weed inventory, the density, and distributions of those populations from previous years for general reference, if determined to be useful by the QP-Invasives.
- **Identify locations that need to be inventoried** – Gather a list of known land parcels and activities, as well as access corridors; provide maps of these parcels and how to access these locations. Focus on identifying data gaps. Conduct surveys and a complete inventory of areas at the earliest practical time, prior to or during development. Identify areas to avoid, newly active locations, dormant disturbed locations, and the edges of disturbed locations.
- **Timing of field surveys** – Ensure that field surveys and inventories are performed prior to or during activities, throughout the growing season, and in areas where data gaps were identified. Identify any invasive weed populations and implement mitigation measures through planning and control. Initial field surveys can take place before construction commences either during any time of the growing season or by using historical data during winter conditions to outline practical areas of known populations of invasive species.
- **Standardize survey procedure and methodology** – Each site must have a unique name, location description, GPS coordinates, and a map. Each site will have a description of the distribution, density, and area of each invasive weed species present. Contractors will use the provincial standard FLNRO “Invasive Alien Plant Program” (IAPP) Field Forms and Application, available at: <https://www2.gov.bc.ca/gov/content/environment/plants-animals-ecosystems/invasive-species/iapp>

or an equivalent form of data collection.

- **Data recording, reporting procedures and methodology** – Follow the standard data collection process, see appendix 3, which accounts for all the information that needs to be recorded. This data collection process must reflect the requirements of the applicable PMP (see section 3). All data recorded must be stored as instructed by the QP-Invasives and submitted to the BC Hydro Representative in the weekly environmental monitoring report section Invasive Weed Management Activities. The QP-Invasives must sign off that all invasive weed management activities have been performed and completed to their professional standards.

Section 3.2: Exposed Land and Borrow Management Plan

The following controls are recommended to reduce the introduction of noxious and invasive weeds through the movement of construction materials.

- **Survey and inventory borrow areas prior to use** – Borrow areas must be evaluated for invasive weed species prior to any material being removed and transported to a new location. These borrow locations will be monitored monthly during the growing and treatment season of May-October and will be treated concurrently for invasive weeds. If a borrow area is known to have a seed-bank or invasive weeds present, the Contractor shall isolate the majority of the contaminated materials through removal of the top 30 cm of soil and keeping those soils isolated at the borrow site. All isolated soils must be clearly identified and prohibited from access. A map and/or inventory will be created for all borrow material locations contaminated with noxious or invasive plant materials for inventory and treatment purposes.
- **Plan soil stockpile areas ahead of time** – Areas where retained soils stripped from construction areas will be stockpiled must be evaluated for invasive weed species prior to material being transported to that location, as per Appendix H of the CEMP. Stockpile locations will be monitored for invasive weed growth monthly. Piles must be shaped for efficient and effective invasive weed management treatment applications, as per Appendix H of the CEMP. A map will be created representing all soil stockpile locations.
- **Soil stockpiles cannot be left bare** – Re-seed all bare invasive soil piles within 30 days after disturbing invasive soils. Certified seed mix, approved by the BC Hydro Representative after reviewing the seed certificates for invasive plants, must be used to reduce the risk of invasive weed growth as per the CEMP requirements. Use of impermeable coverings, such as plastic, to prevent the growth of plants or spread of weeds is also acceptable. Soil stockpiles must be monitored monthly for invasive weed growth. A map must be created of all soil stockpiles.
- **Erosion/sediment control measures at borrow or stockpile locations** – Erosion and/or sediment control measures will be put in place as per the CEMP.

Section 3.3: Vehicle and Equipment Access

The following access controls are recommended to reduce the spread of invasive weeds by vehicles and equipment.

- **Identification of known invasive weed populations** – Areas with known invasive weed populations will be identified in GIS data available on the Site C Data Room in Environmental Sensitivities and must be reviewed prior to working in those areas.
- **Preventative access measures** – Install signage to identify restricted (limited) and prohibited (banned) access in areas of invasive weed populations and information signs about invasive weed control measures. Install fencing, barriers, or other equally effective means to prevent vehicle access through infested areas, as directed by the QP-Invasives. All signage, fencing, and barriers must be durable and have a life span of a minimum of 3 years.
- **On-site cleaning facilities** – There will be a need for on-site cleaning facilities, such as rinse stations or other effective methods of removing the accumulation of debris, for areas with high volumes of traffic (greater than 10 pieces of equipment per hour) and large invasive infestations. The QP-Invasives shall establish the location and type of on-site cleaning facilities and when/how they are to be used (see section 5.3).
 - **Audited records** – Provide record keeping forms at each rinse station/cleaning facility that are mandatory to fill out for each user. A random audit will be performed on the records to ensure all parties involved are participating in the program.
 - **On-site inspector** – There may be a need for a full-time on-site inspector to monitor traffic coming and going in locations with high volume traffic (greater than 10 pieces of equipment per hour). The QP-Invasives shall establish the requirement for this on-site inspector. The role of the inspector will be to determine if the equipment needs to be cleaned or not (see section 5.3) This inspector does not need to be a QP-Invasives.
- **On-site and inter-site access limitations** –The QP-Invasives will develop an effective access plan that will control and mitigate noxious weeds on and within the site. The QP-Invasives may delineate the project area into containment zones, or if more suited, they may treat the entire project area as a single containment zone. Factors that must be taken into consideration when delineating containment zones are weed species, weed density, land ownership, resource values, and traffic levels. The goal of the containment zone is to ensure that there are no new introductions of invasive species as well as preventing the spread of current infestations inside and outside of the project boundaries.

Smaller containment zones may be established to isolate a noxious weed population and its seed bed. In this case the containment zone will require signage restricting access and a clear visible boundary established. These zones also must be mapped.

In order to ensure that noxious weed populations do not enter, spread throughout, or leave the project area, cleaning stations and measures will be required at or near the main point of entry/exit. This can be a power rinse station or any other effective method where debris accumulation is removed from the vehicle or equipment. The following rules will ensure the containment zones remain effective:

1. All vehicles will come to the site (containment zone) clean and free of any debris or seed sources from other areas.

2. While in the site (containment zone), vehicles that have travelled off designated roadways or through vegetated areas must clean before exiting.

The QP-Invasives should monitor the effectiveness of the plan as well as audit the participation of the workers this plan applies to.

Section 4: Educate Work Force

The following education opportunities for contractors and on-site personnel are recommended to increase the awareness of the invasive weed control program on Site C.

- **Invasive weed indoctrination training** – Basic invasive weed awareness training will be provided during orientation and pre-construction kickoff meetings. Workers must know how to report sightings to their supervisor. Educational posters will be designed by the QP-Invasives to contain at a minimum: common invasive weeds, how to report sightings and contractor contact numbers. Posters must be placed in common areas, such as the lunchroom.
- **Place signage on site with invasive weed information** – Signs will be posted to provide education and warning. Signs must be placed at rinse station locations and need to include, at a minimum: when to use the rinse station, instructions for use of the rinse station, PPE requirements and contact numbers to report problems with the rinse station. Prohibited and restricted area signage must indicate, at a minimum: no-work zone due to invasive weeds. All signs must be durable and permanent and be highly visible.
- **Early Detection Rapid Response (EDRR)** – By encouraging workers and contractors to report the first sighting of an invasive weed, this program will be a very effective way of preventing invasive weeds from becoming established in an area. Workers must report sightings to their supervisor. The supervisor must fill out the report-a-weed form (see Appendix 3) and submit to the QP-Invasives. All sightings of noxious or invasive weeds must be reported and followed up on through site visits by the designated QP-Invasive.

Section 5: Implement Control and Mitigation

The contractor is responsible for noxious and invasive weed mitigation and control measures for populations that are present within their work areas. Those areas outside of the contractor's work area, but within the project footprint, will be mitigated and controlled by BC Hydro as required.

The following mitigation and control measures need to be employed to effectively manage existing weed populations and prevent the introduction and proliferation of invasive weeds within active construction work areas.

In areas where there are substantial noxious weed populations, containment zones should be setup by the QP-Invasives to prevent the distribution of plant matter to other weed free areas (see Section 3.3).

Section 5.1: Herbicide Application

- **Determine treatment plan** – Plan herbicide treatment prior to March 1st based on historical invasive weed inventory and treatment records, provide estimated area projections of noxious weed populations that may occur in the upcoming year to the owner of the applicable Pest Management Plan (PMP) (see section 3). Review the new areas of the project and estimate the projections for the following year.
- **Prioritize treatment sites** – Invasive weed species will be prioritized in accordance with the PRRD “Invasive Plant Program Strategic Plan and Profile” for the most current year. According to the BC Weed Control Act, all noxious weeds must be controlled. Regional and Provincial Early Detection Rapid Response (EDRR) and Category A species are highest priority for treatment (See Appendix 2). Category B listed species can be prioritized second but need to be treated if they have a small infestation size (less than 0.25 ha) or if land values are threatened, irrespective of infestation size.
- **Determine the best herbicide application method for each invasive weed population** - The herbicide applicator and QP-Invasives must consider which herbicide is best to use for the species present and their location (proximity to water, riparian, or sensitive habitat). In order to ensure proper treatment planning, review the label on each herbicide and/or consult with an herbicide expert. Verify the applicable PMP is utilized for the area and other legislation is adhered to. The QP-Invasives must carefully consider herbicide application to fill materials if they are planned to be moved to a sensitive habitat or water body area.
- **Determine treatment frequency** – Invasive weed species may require multiple control applications to attain successful control. Determine this frequency based on the invasive weed species present, germination characteristics, weather conditions, etc. Ensure that treatment is at a frequency rate that will ensure successful control of invasive weeds (See table 2).
- **Determine treatment boundaries** – Observe and field mark all zones applicable to the PMP and herbicide labels. Buffer zones must be established to protect rare plants, as determined in the CEMP at to the satisfaction of the QP-Invasives.

- **Prepare treatment equipment** – Check and calibrate equipment prior to work. Maintain calibration records as per applicable PMP.
- **Complete herbicide treatment of sites** – Chemically treat invasive weeds as per the treatment plan, applicable PMP(s) and in accordance with all legislation. Herbicide treatment must be performed by a certified pesticide applicator with certified assistant applicators if required.
- **Communication**– Contractors must include a standing Invasive Weed Management section in their weekly environmental monitoring report. This section must include all forms in Section 9 (see Appendix 3), and any other forms suggested by the QP-Invasives. If no invasive weed management activity occurred for the period the contractor must provide reasons why in this standing section.

Section 5.2: Mechanical Control

- **Determine treatment type** – Mechanical control usually refers to the mowing of an invasive plant infestation to limit seed production. With mowing, timing is essential. Invasive plants must be mowed before the plants go to seed in order to be an effective method of control. Plants should be mowed as close to the ground as practical.
- **Prioritize treatment sites** – Invasive weed species will be prioritized in accordance with the PRRD “Invasive Plant Program Strategic Plan and Profile” for the most current year (See Appendix 2). Regional and Provincial Early Detection Rapid Response (EDRR) and Category A species are highest priority for treatment. Category B listed species can be prioritized second but need to be treated if they have a small infestation size (less than 0.25 ha) or if land values are threatened, irrespective of infestation size.
- **Determine treatment frequency** – Invasive weed species will require multiple control treatments to attain successful control. Determine the frequency based on the invasive weed species present, germination characteristics, weather conditions, etc. Consecutive mechanical treatments must be done periodically in order to prevent the weed populations from flowering. Ensure that treatment is at a frequency rate that will ensure successful control of invasive species (see Table 3).
- **Determine treatment boundaries** – Buffer zones must be established to protect rare plants, as determined in the CEMP at to the satisfaction of the QP-Invasives.
- **Mechanical treatment on sites** – Mechanical treatment may occur in areas where chemical applications are prohibited or not feasible. Method of mechanical treatment will be determined by the QP-Invasives (tractor mower, gas powered trimmers, manual hand pulling, etc.).
- **Communication** – Contractors must include a standing Invasive Weed Management section in their weekly environmental monitoring report. This report must include all forms in Section 9 (see Appendix 3), and any other forms suggested by the QP-Invasives. If no invasive weed management activity occurred for the period the contractor must provide reasons why in this standing section. Treatment records will be included in the Annual Use Summary.

Section 5.3: Rinse Station Mitigation

Rinse Station Definition - Rinsing involves the use of water to remove accumulations of dirt, debris, and weed matter from equipment. It includes, but is not limited to, the use of pressure washers, fixed rinse stations, and commercial vehicle rinse facilities.

- a. Rinse stations consist of a facility constructed to clean vehicles as they enter or leave an area. They typically consist of a fixed unit to clean vehicles as they drive through and a pump unit to hand rinse larger equipment using a spray wand.
 - b. Temporary rinse stations consist of an enclosed trailer unit with external water supply and a pressure washer unit to hand rinse equipment.
 - c. Portable rinse stations consist of an enclosed unit with water supply and pressure washer to hand rinse equipment in the field or to establish temporary rinse stations.
 - d. Commercial facilities are the local car washes and company rinse bays. These are off site facilities and will typically be used prior to entering the site.
 - e. Steam trucks consist of a truck with water supply, a pump, and heater to produce hot water or steam. They can be used to clean equipment in the field or at a rinse station.
- **Rinse station location** - Based on the volume of traffic, the size of the infestation within the containment area and the accessibility of the station. This will need several steps:
 - a. An initial inventory to determine the species present at the work site and in surrounding lands needs to be undertaken prior to establishing rinse sites. Administrative areas to control the spread of weeds will need to be established.
 - i. Work area will be based on weed population, work being performed, and land ownership boundaries (i.e. a private field with thistle will be considered a separate work area from a private field without). Rinsing equipment will be used between work areas if weed population are different from adjacent.
 - ii. Containment zones will consist of several work areas in a region with similar weed populations and conditions, as determined from past inventories. Containment zones may contain several different job sites with multiple contractors.
 - b. Placement of rinse stations must be at the main access points to a containment zone
 - i. Priority will be to prevent the spread of weeds in and out of the containment zone.
 - c. Placement of temporary rinse stations will be to control the spread of weeds between work areas within the containment zones.
 - i. Priority will be to prevent the spread of weeds into private and agricultural land.
 - **When to rinse** - All mobile equipment (any source of transportation) must complete a full equipment rinse to remove all mud, soil, seeds, and weed material on or held within equipment under the following circumstances:
 - a. When leaving or entering a containment zone or when entering a work area that does not contain the same weed species as the one being left.
 - i. If the mobile equipment has travelled through vegetation.
 - ii. If the mobile equipment has travelled off of designated roadways.
 - b. If the mobile equipment has travelled through documented or undocumented infestations.
 - i. Documented infestations will be field marked.

- **Do not rinse** – Vehicles and equipment do not need to rinse when:
 - a. Travelling within a work area.
 - b. Travelling on designated roadways to a different work area within the same containment zone.
 - c. Travelling from an area with no invasive weed populations to one with weed populations.
- **Full rinse** must include:
 - a. Full rinse of all undercarriage of equipment.
 - b. Full rinse of all wheel wells, body panels, tires & rims, etc.
 - c. Rinsing of any other areas where dirt or material may accumulate as required
 - d. The majority of dirt and other materials must be removed.
 - e. Using the automated rinse stations may leave excessive material behind. This will be removed by hand rinsing with a pressure wand if needed.
- **Other considerations** - Rinsing of construction materials such as swamp mats must be done before they are moved. If rinsing is not feasible then stockpiling on site and disposal is recommended. A means of controlling greywater, such as a sump, must be constructed. All rinsed off sludge can be piled and monitored for invasive plant growth until a time where it must be buried in a relocated surplus excavated materials (RSEM) location that will not be flooded or another suitable location, as directed by the QP-Invasives.
- **Data Collection** -
 - a. Each rinse station will have a logbook to record usage. Data collected must include:
 - i. Name and Company Name
 - ii. Date and Time
 - iii. Vehicle/Equipment type
 - iv. Reason for rinse
 - b. Logbook data will be collected periodically, and usage and compliance reports generated.
 - c. Rinse stations with high traffic may require an on-site inspector to verify rinse station usage and collect data.

Section 5.4: Seasonal Mitigation

- **Winter Control** – Utilizing snow in inclement weather to ensure plant matter is not transported.
 - a. In work areas, bury known infestations to cover entire plants.
 - b. During snow clearing activities, with safety still paramount, if feasible, leave a layer of snow pack on road ways to prevent debris and material from contaminating equipment and being transported.
 - c. When constructing new roads, blade the ground in areas of known infestations.
- **Mitigation** - Steam cleaning or air blasting can be used as a method to clean vehicles and equipment in inclement weather.

Section 6: Implementation

Table 1: Mitigation Control Methods and Responsibilities

Mitigation Control	Condition to Apply Control	Mitigation Methods	Responsibility
Rinse Vehicles and Equipment	<ul style="list-style-type: none"> - Travelled through vegetation - Travelled off-road - Leaving containment zone - Equipment cleaned prior to transport from site 	<ul style="list-style-type: none"> - Rinse stations - Steam truck cleaning - See instructions on mobile equipment rinsing procedures 	BC Hydro and Contractors
Herbicide Treatment	<ul style="list-style-type: none"> - After appropriate notification to First Nations, public, landowners, etc. - As specified on the herbicide label - During proper weather conditions - Following herbicide label and PMP guidelines 	<ul style="list-style-type: none"> - Backpack application - Pump powered application equipment (E.g. Truck mounted spray tank with hose and reel) - Wipe-on application, especially on vegetation near sensitive habitats - Boom spraying with pump powered equipment mounted on mobile equipment - Cut stump application - Hack and squirt 	Contractors
Mechanical Treatment	<ul style="list-style-type: none"> - Near sensitive habitat (riparian areas, rare plants, etc.) - On coarse soil types when herbicide is not ideal 	<ul style="list-style-type: none"> - Digging - Hand-pulling - Mowing - Brushing - Dead-heading (flower and/or seed removal) 	Contractors
Certified Grass Seeds	<ul style="list-style-type: none"> - Bare exposed soil surfaces or stockpiles for 30 days, as per CEMP - Disturbed areas, either somewhat active or dormant - In areas where native vegetation requires assistance to become re-established 	<ul style="list-style-type: none"> - Seed spreaders: hand held or rolling - Hand spreading - Hydro-seeding - Powered spreading equipment: tractor with seed spreading attachment 	Contractors
Education	<ul style="list-style-type: none"> - New contractors or workers on site - New invasive weed population has been found on site - Early detection rapid response (EDRR) 	<ul style="list-style-type: none"> - Reporting procedures - Inclusion in orientation - Posters, signs, etc. 	BC Hydro and Contractors
Preventative Access Measures	<ul style="list-style-type: none"> - Known invasive weed population locations - At permitted or prohibited parking and storage locations 	<ul style="list-style-type: none"> - Install signs - Install barriers - Install fences 	Contractors
Vehicle and Equipment Access	<ul style="list-style-type: none"> - To help contractors avoid driving through or accessing areas with invasive weed populations. - Contractors need to access infested areas 	<ul style="list-style-type: none"> - Use Site C Data Room to create maps of areas with invasive weed populations and permitted travel corridors - Consult with QP-Invasives - Conduct meeting with contractor(s) prior to travelling through site 	Contractors

Section 7: Assess Effectiveness

The following monitoring methods are recommended to assess the effectiveness of control and mitigation measures.

- **Review the implementation of the entire program** – The QP-Invasives shall assess if plan development strategies are working by reviewing all treatments, site access plans, fill and pile spoil management plans, and site remediation plans.
- **Review treatment records and schedule inspections** – BC Hydro must plan to conduct their own inspections of treatments that are completed by the Contractor. Monitoring the efficacy of treatments is essential to finding out if re-treatment is necessary or if the current approach needs to be changed. The Contractor must check treatment records to schedule appropriate post-treatment inspection dates, approximately 2 weeks following treatment.
- **Perform post-treatment inspections** – Determining the success of mechanical and chemical treatment activities will be based on visual observations conducted by the QP-Invasives. The percentage of kill on weed species and observed rates of germination, regrowth and plant vigour after chemical treatment will determine the efficacy treatment (Table 2). Inspection records are to be included in contractor’s weekly monitoring report.

Table 2: Efficacy of Herbicide Treatment

Herbicide Treatment	Kill Percentage	Species Set Seed	Reduced Regrowth and Germination
Successful (Control)	>85%	No	Yes
Satisfactory (Suppression)	>75%	No	No
Unsatisfactory	<75%	Yes	No

For mechanical treatment, the measure of success has been altered to best describe the effects of the specific treatment.

Table 3: Efficacy of Mechanical Treatment

Herbicide Treatment	Species Set Seed	Reduced Regrowth and Germination
Successful (Control)	No	Yes
Satisfactory (Suppression)	No	No
Unsatisfactory	Yes	No

Record if sites need re-treatment, and perform as required. Areas adjacent to treated invasive weed populations must also be monitored.

Section 8: Monitor & Enforce Processes

The following enforcement recommendations are necessary to ensure measures are being implemented. Monitoring must be done consistently throughout the year, as defined by the QP-Invasives.

- QP-Invasives must monitor that the control efforts are executed and check the effectiveness of this plan and their compliance to it.
- BC Hydro must audit the records, processes and procedures are being followed by the contractors.
- BC Hydro must audit that all contractors are operating within the appropriate Pest Management Plan.

Section 9: Reporting

The following reporting tools and frequencies are required for regular communication, notice of intent to treat, and annual use summaries. Contractors must include a standing Invasive Weed Management section in their weekly environmental monitoring report. This section must include all forms listed below, and any other forms suggested by the QP-Invasives. If no management activity has occurred for the period, it must also be recorded and shared in the daily operation records in weekly environmental monitoring report.

- **Daily operation records** – Daily operation records required by the applicable PMP (see section 3) will be kept by the Contractor on all weed mitigation activities that have taken place each day and supplied to BC Hydro weekly. Daily operation records will include all mechanical treatments, chemical treatments, and post-treatment inspections.
- **Weekly reports** – On a weekly basis, records will be shared with the BC Hydro Representative from the Contractor outlining daily activities of the past week, and plans for the following week. These shall be delivered via the Weekly Environmental Monitoring Reports.
- **Data collection** – Contractors will provide all original data to BC Hydro on a weekly basis. This data will include GPS coordinates, maps, pictures, field notes, and raw data records, as well as any other data required by the PMP (See Section 3). BC Hydro will collect and store this data.
- **Submit Notice of Intent to Treat** – BC Hydro needs a plan as to where and when treatment is going to take place. This notice must be submitted at a minimum of 21 days prior to treatment.
- **Mandatory reporting of major problems** – Contractors must notify BC Hydro personnel as soon as practical if a major issue occurs or if there is a break down in the management process.
- **BC Hydro annual invasive weed management report** – BC Hydro to provide an annual report that will be used for planning the following year. Annual report will be based on a site survey, review of treatments, and will include recommendations for adaptation of the plan if required. Due by January 15th.
- **Contractor annual work plan** – Contractor will create and submit an annual invasive weed management work plan to BC Hydro prior to implementation for review by March 1st. The document will outline the intended areas of treatment for the upcoming year and fulfil the requirements of the Notice of Intent to Treat. This information will be used to submit the Notice of Intent to Treat.
- **Annual Use Summaries** – At the end of the year BC Hydro will collect all data and summarize into an annual report to be submitted to the Ministry of Environment before January 31st. The Contractor will provide a summary of the prior year's treatment program which will include maps of each treatment area, total volumes of herbicides used at each treatment area and the associate hectares treated. This will be due by December 15th.

Section 10: Frequency of Program Activities

Table 4: Frequencies

Program Task	Time Frame	Periodicity
Program administration	January 1-December 31	Ongoing, daily as needed
Notice of Intent to Treat (NIT)	21 days prior to treatment (Estimate April)	Once
Review historical data and mitigation efforts	January 15-April 1 or as soon as practical after contract award	Once
Field Survey and Inventory	April 15(Snow free)-September 31	Twice - beginning and end of season
Mapping	January 1-December 31	Ongoing
Plan development and ongoing assessment	January 1-December 31	Ongoing
Contractor training and education	January 1-December 31	Prior to work commencement and as needed
Herbicide, mechanical control, and post treatment inspection	As required by pesticide label May 1-October 31	One treatment and final inspection Mechanical control - Ongoing
Vehicle and equipment access implementation	January 1-December 31	Prior to field season and as needed
Exposed Land and Borrow Management plan implementation	January 1-December 31	Prior to field season and as needed
Site Remediation Plan implementation	January 1-December 31	Prior to field season and as needed
Assessment of mitigation and control measures	September 31-December 31	Post field season - Once
Monitoring and Enforcing Plan Implementation	January 1-December 31	Ongoing
Daily Operation Reports (DORs)	April 15 –October 30	Daily
Weekly Environmental Monitoring Report	January 1 – December 31	Weekly
Monthly Report and Communication log	January 1-December 31	Monthly
Year-end Final Report	October 1-December 31	Once
Annual Use Summary	December 1-December 31	Once

Appendices

Appendix 1: Task List and Responsibilities

Table 5: Task List and Responsibilities

Task – Plan Development - Review Historical Data, Field Surveys, and Inventory				
Task Number	Sub-task	Task Details	Contractor Responsibility*	BC Hydro Responsibility*
1	Gather all historical data of treatment activities and inventories			Provide all historical data, including maps.
2	Review where invasive weeds have been found in the past.	Review the density, distribution, and area of past invasive weed populations.	Review inventory information.	
3	Review how invasive weed populations were treated in the past.	Review how sites were managed.	Review treatment information.	
4	Reviews if there have been major changes to historical sites.	Review if there has been activity or development in areas with historical invasive weed populations.	Review maps of the site from before and currently.	
5	Assess viability	Evaluate past control and mitigation measures for viability moving forward with the enhanced management plan.	Review past processes and assess if those processes should still be utilized on site.	
6	Gather a list of known parcels and activities, as well as access corridors.		Prioritize areas that need to be surveyed and inventoried.	Provide access to GIS data on Site C Data Room
7	Conduct surveys and inventory of areas prior to or during development.	GPS and photograph sites	Perform field survey.	
8	Conduct surveys of newly active areas.	GPS and photograph sites	Perform field survey.	
9	Conduct surveys of dormant disturbed locations.	GPS and photograph sites	Perform field survey.	
10	Conduct surveys at the edges of disturbed locations.	GPS and photograph sites	Perform field survey.	
11	Standardize survey procedure for recording data.	Each site will have a unique name, location description, GPS coordinates, and a map. Each site will have density, distribution, and area data for each species present.	Collect all necessary information for each site during inventory surveys.	

Task Number	Sub-task	Task Details	Contractor Responsibility*	BC Hydro Responsibility*
12	Standard reporting procedures.		Provide raw data records and summaries in the weekly environmental monitoring report under section: Invasive Management Activities	Review information and audit records
13	Develop containment zones	Evaluate traffic and infestation to determine rinse station installment	QP-Invasives to determine containment Zones	
Task - Plan Development – Exposed land and Borrow Management Plan				
Task Number	Sub-task	Task Details	Contractor Responsibility*	BC Hydro Responsibility*
14	Survey and inventory borrow areas in advance of Use	Source areas must be evaluated and inventoried ahead of material extraction.	Monitor planned source locations for invasive weed populations. Do not use materials from areas with an invasive weed seed-bank. Leave infested materials at the borrow site, to the QP-Invasives satisfaction.	Provide list and access to GIS data in Site C Data room for all source locations.
15	Plan stockpile areas ahead of time.	Stockpile areas must be evaluated ahead of time.	Provide list and map of all stockpile/spoil areas. Infested materials must be stockpiled in a designated location. Monitor spoils locations for invasive weed populations. Prohibit access to these areas.	
16	Stockpiled soil cannot be left exposed for a period greater than 30 days	Re-seed exposed soil.	Review seed certifications to ensure no invasive weeds are introduced to project area Re-seed all bare soil with certified seed. Monitor areas for invasive weed populations.	Audit contractors to determine compliance with procedures.
17	Erosion and sediment control.	Erosion and/or sediment control measures will be installed if water or sediment movement is likely, as per the CEMP.	Install erosion and sediment control measures where necessary. Monitor these locations for invasive weed populations.	Audit contractors to determine compliance with procedures.

Task - Plan Development – Vehicle and Equipment Access				
Task Number	Sub-task	Task Detail	Contractor Responsibility*	BC Hydro Responsibility*
18	Identification of invasive weed populations that require access restrictions	Identify areas with invasive weed populations where restrictions can be applied to limit the spread of invasive weeds.	Provide data and digital maps.	Review data and digital maps.
19	Contract specifications	Each contract will have expectations for participation in the Invasive Weed Mitigation and Adaptive Management Plan (IWMAMP)	Review contracts for these specifications.	Include specifications in contracts. Review contracts for these specifications.
20	Signage	Place signage in areas of restricted or prohibited access.	Install signage. Monitor that signs remain in good condition. Perform maintenance as required.	Obey all site access restrictions put in place.
21	On site access limitations	Traffic through infested areas must be regulated and monitored	Obey all site access restrictions put in place. Make sure restricted areas are well marked and have appropriate signage in place.	Obey all site access restrictions put in place. Audit sites to ensure that restrictions are being followed.
22	Inter site access limitations	Vehicle travel between sites must be limited when practical.	Leave equipment in the same location on site for the duration of the project, when practical.	Leave equipment in the same location on site for the duration of the project, when practical.
23	Barriers to prevent access	Install barriers to prevent vehicle access.	Install fencing, signage and barriers where necessary, as dictated by the QP-Invasives	Audit contractors to determine compliance with procedures.
24	Utilization of onsite Rinse Stations	Rinse stations will be placed at main access points of containment zones Temporary rinse station will be located between works areas of different invasive species.	Clean vehicles before travelling to other areas and when leaving site	Clean vehicles before travelling to other areas or when leaving site
25	Rinse records	Keep records at rinse station for each user.	Complete rinse station logs	Complete rinse station logs. Complete random audits of logbook for compliance.
26	On site inspector	Monitor traffic coming on and off site.	Inspector to ensure rinse station use compliance	Audit contractors to determine compliance with procedures.

Task - Educate Work Force				
Task Number	Sub-task	Task Detail	Contractor Responsibility*	BC Hydro Responsibility*
27	Invasive weed indoctrination awareness.	Invasive weed information provided in welcome orientation. Outline how to report invasive weed sightings.	Ensure that all employees and contractors participate in the orientation. Provide awareness and outline of how to report.	
28	Place signage on site with invasive weed information.	Signs/posters must be placed in common areas for educational purposes. (i.e. Camp housing and lunchroom)	Where practical install signage /posters to maximize exposure to work force. Maintain posters.	
29	Early detection rapid response (EDRR).	Encourage workers and contractors to report any sightings of invasive weeds on site.	Follow up with reports. Record and report all sightings of invasive weeds on site.	
Task – Implement Control and Mitigation - Herbicide Application				
Task Number	Sub-task	Task Detail	Contractor Responsibility*	BC Hydro Responsibility*
30	Determine treatment plan for upcoming year by March 1 st	Check historical invasive weed inventory and treatment records from the previous year of treatment, if available. Review new areas of the project and provide estimated area projections of invasive weed populations that may occur in the upcoming year.	Determine the areas of treatment by size and location for the upcoming year, including new sites. Create a digital map that identifies these locations and satisfies the requirements of Section 42 of the Integrated Pest Management Regulations.	Collect the data and engage all First Nations groups that are impacted by the applicable Pest Management Plan (see section 3), this should occur between March 1 st to April 30 th . Submit the Notice of Intent to Treat for the applicable Pest Management Plan at a minimum of 21 days prior to treatment. This should occur by May 1 st at the latest.
31	Prioritize treatment sites by invasive weed species as per the PRRD prioritization list and jurisdiction.	Higher priority species must be treated first, followed by lower priority species. Sites located near or on agricultural land must be prioritized.	Review sites and create prioritization list.	Review list and provide input.
32	Determine treatment method and herbicide to be used.	Evaluate each location in accordance to herbicide application regulations and species present to choose the best herbicide for treatment.	Develop treatment plan from invasive weed inventory and additional information.	Audit contractors to determine effective implementation of the plan
33	Determine treatment size.	Refer to maps.	Determine treatment size from invasive weed inventory surveys.	
34	Determine treatment frequency.	Based on invasive weed species, germination, weather conditions, etc.	Ensure that treatment is at a frequency rate that will ensure successful control.	Audit frequency to ensure targets are satisfied.

Task Number	Sub-task	Task Detail	Contractor Responsibility*	BC Hydro Responsibility*
35	Establish procedures and system for treatment and data collection prior to treatment.	Data records are required for all and any herbicide application activities.	Standardize herbicide application procedures.	Ensure application procedures are appropriate to the applicable Pest Management Plan.
36	Order herbicide.	Order the specific herbicides that are to be used on site for the specific invasive species present.	Order appropriate amount of PMP permitted herbicides.	
37	Prepare treatment equipment.	Set up and calibrate all spray equipment	Prepare treatment equipment for field season. Maintain calibration records.	
38	Maintain application equipment.	Check and calibrate at the start of each shift. If equipment is not working properly it must be repaired before use	Ensure proper functioning of application equipment. Calibration records	Periodically inspect equipment to ensure no environmental damage could occur.
39	Complete treatment of sites.	Only certified applicators can supervise herbicide application.	Treat invasive weed sites as per the treatment plan.	
40	Complete all forms and paperwork required	IAPP forms, DORs, communication, etc.	Submit all forms, paperwork, and data via the Weekly Environmental Monitoring Report under section: Invasive Weed Management Activities. The QP-Invasives must sign off on the weekly section.	Collect and store all forms for submission to Government agencies.
Task – Implement Control and Mitigation - Mechanical Control				
Task Number	Sub-task	Task Detail	Contractor Responsibility*	BC Hydro Responsibility*
41	Determine treatment plan for upcoming year by March 1 st	Check historical invasive weed inventory and treatment records from the previous year of treatment. Review new areas of the project and provide estimated area projections of noxious weed populations that may occur in the upcoming year.	Determine the areas of treatment by size and location for the upcoming year. These areas should be based on all historical sites, survey data and projections of practical weed populations in new areas of the project. Create a digital map that identifies these locations and satisfies the requirements Section 42 of the Integrated Pest Management Regulations.	Collect the data and engage all First Nations groups that are impacted by the applicable Pest Management Plan. This should occur between February 1 st to April 30 th . Submit the Notice of Intent to Treat for the applicable Pest Management Plan at a minimum of 21 days prior to treatment. This should occur by May 1 st at the latest.

Task Number	Sub-task	Task Detail	Contractor Responsibility*	BC Hydro Responsibility*
42	Determine treatment type.	QP-Invasives to decide best method.	Develop treatment plan from invasive weed inventory information.	Ensure mechanical procedures are appropriate to the applicable Pest Management Plan
43	Determine treatment size.	Refer to maps.	Determine treatment size from invasive weed inventory survey information and projected invasive weed populations.	
44	Determine treatment frequency.	will require multiple control applications to attain successful control.	Ensure that treatment is at a frequency rate that will provide successful control.	
45	Establish procedures and system for treatment and data collection prior to treatment.	Refer to the BC Government Invasive Alien Plant Program website for example data collection procedures and forms.	Standardize mechanical treatment procedures and data collection.	Ensure application procedures are appropriate to the applicable Pest Management Plan.
49	Prepare and maintain equipment.	Check equipment at the start of each shift.	Ensure proper functioning of treatment equipment.	Periodically inspect equipment to ensure no environmental damage could occur.
47	Complete treatment on sites.	Treatment will be completed before invasive weeds go to seed.	Treat sites with applicable equipment.	
48	Record treatment information.	GPS, photos, daily operation records.	Provide raw data records to BC Hydro in the Weekly Environmental Monitoring Report under section: Invasive Management Activities. The QP-Invasives must sign off on weekly section.	
49	Complete all forms and paperwork required.	IAPP forms, DORs, communication, etc.	Submit all forms, paperwork, data collected, and summaries to BC Hydro in the Weekly Environmental Monitoring Report under section: Invasive Management Activities	Collect and store all forms for submission to Government agencies.
Task – Implement Control and Mitigation – Winter Mitigation				
Task Number	Sub-task	Task Detail	Contractor Responsibility*	BC Hydro Responsibility*
50	Pack snow over infestations when practical.		Pack snow over infestations using track equipment when practical.	
51	Avoidance of invasive weed seed beds.	Field mark off areas of infestation to avoid.	Avoid areas that have been marked off. Find alternative access if practical.	Avoid areas that have been marked off. Find alternative access if practical.

Task Number	Sub-task	Task Detail	Contractor Responsibility*	BC Hydro Responsibility*
52	Steam cleaning	Mobile equipment must be cleaned before going to a new site.	Clean all mobile equipment before going between sites or to a new site. Refer to Mobile Equipment Rinse, Section 5.3	
53	Evaluate	Refer to inventory information and determine if sites have the same species infestations, cleaning mobile equipment before going between them may not be necessary if they have the same species present.	Evaluate if mobile equipment needs to be cleaned.	Evaluate if mobile equipment needs to be cleaned.
54	Snow clearing	During snow clearing activities, with safety still paramount, if feasible, leave a layer of snow pack on road ways to prevent debris and material transportation	Grading equipment should avoid grading snow off of the road back down to bare soil.	
Task - Assess Effectiveness				
Task Number	Sub-task	Task Detail	Contractor Responsibility*	BC Hydro Responsibility*
55	Check treatment records and schedule inspections.	Check treatment records for appropriate post-treatment inspection dates, approximately two weeks following treatment.	Conduct post-treatment inspections. Conduct periodic inspections of sites. Assess reduction in populations.	Provide regular results of inspections and audits to ensure proper procedures are enforced and for overall program enhancement.
56	Monitor areas adjacent to treated area for new invasive weed populations.	If practical arrange mitigation measure with other parties where invasive populations are off project areas but impacting the project.	Monitor adjacent areas for any invasive weed populations.	Contact adjacent land owners and attempt coordination of mitigation measures for the invasive weed populations adjacent to the project.
57	Assess the effectiveness of the entire management plan.	Assess if plan development strategies are working.	Review the Vehicle and Equipment Access Plan and Exposed Land and Borrow Management Plan for effectiveness and execution.	Review the effectiveness of the management plans with the contractors. Also review inspection and audit results to ascertain trends of procedures that are successful and those that fall short.

Task - Monitor and Enforce Processes				
Task Number	Sub-task	Task Details	Contractor Responsibility*	BC Hydro Responsibility*
58	Make sure invasive weed control and mitigation measures are being implemented.	Inspect and audit on a basis that ensures that all procedures and process are being followed for the most effective mitigation of invasive weeds.	Follow contract specifications and self-audit and inspect on a regular basis to verify proper implementation.	Ensure contract specifications are being followed and audit and inspect on a regular basis.
59	Review if the process is being utilized correctly and if the contractors are following the procedures outlined.	Plans developed must be implemented properly and according to regulations.	Follow plan specifications and self-audit and inspect on a regular basis to verify proper implementation.	Audit processes.
60	Review that all contractors are operating within the legislative boundaries.	All rules and regulations for invasive weed management, control and mitigation measures need to be followed.		Audit contractors.
Task - Reporting				
Task Number	Sub-task	Task Details	Contractor Responsibility*	BC Hydro Responsibility*
61	Complete data collection as set forth in this plan.	Maintain daily operation records. Data must include GPS coordinates, maps, pictures, field notes, and raw data records.	Daily operation records will be included with the Weekly Environmental Monitoring Report under section: Invasive Weed Management Activities.	BC Hydro will collect and store this data.
62	Submit Notice of Intent to Treat 21 days prior to planned herbicide application.	Plan when treatment is going to be executed and submit notice of intent to treat ahead of time.	Provide following years plan by March 1 st .	Review plan to be within the bounds of the CEMP and the applicable PMP. Engage First Nations on the plan for any cultural issues. Verify when notice has been submitted. Submit Notice of Intent to Treat 21 days prior to planned herbicide application.
63	Report monitoring findings to BC Hydro.		All monitoring activities and findings must be reported to BC Hydro personnel.	
64	Mandatory reporting of major problems.		Contractors will notify BC Hydro personnel if a major issue occurs or a there is a break down in the management process.	

Task Number	Sub-task	Task Details	Contractor Responsibility*	BC Hydro Responsibility*
65	BC Hydro annual invasive weed management report			Provide an annual report of the year that will be used for planning the following year. Based on site survey, review of treatments, and recommendation. Due January 15th.
66	Contractor annual work plan		Provide an annual invasive weed management work plan to BC Hydro prior to January 15 th . Outline intended areas of treatment for upcoming year	
67	Annual Use Summaries	Collect all data from year and summarize into annual report.	Summarize data from year and provide it by Dec 15th.	Submit Annual Use Summary on or before January 31 st .

Appendix 2: Classification Tables of Invasive Weed Species

Invasive species classification within the Peace River Regional District (PRRD) can be found at the following link:

<https://prrd.bc.ca/services/invasive-plants/plans-reports-invasive-plants/>

The classification tables are updated annually, usually in April.

A list of provincially and regionally regulated noxious weeds and additional unregulated weeds of concern in BC can be found at the following link:

<http://bcinvasives.ca/invasive-species/about/regulated-invasive-species-in-bc/list-of-regulated-invasive-plants-in-bc>

A list of BC's Proposed Prohibited Noxious Weeds can be found at the following link:

https://www2.gov.bc.ca/assets/gov/environment/plants-animals-and-ecosystems/invasive-species/guidance-resources/proposed_prohibited_noxious_weeds.pdf

Appendix 3: Field Forms



BRITISH COLUMBIA
The Best Place on Earth

Ministry of
Forests and Range

INVASIVE PLANT CHEMICAL & MECHANICAL TREATMENT RECORD



PCP No. 24-D-14725, Barvel 16637, Excerpt 20035, Minsite 28137
 Rastros 28137/26371, Vangajati 26593, Giazon 26648
 Roundup 13644, Tison 22K 9005, Translino 24084

<input type="checkbox"/> DATA ENTERED INTO WFP		ENTERED BY:		OTHER HERBICIDE		REGISTRATION #	
TREATMENT DATE	YR/MO/D	AGENCY	EMPLOYER	CERTIFIED APPLICATORS	CERT. NUMBER	OTHER APPLICATORS	CERT. NUMBER
RANGE UNIT	PASTURE	PAPER FILE ID	PIP NUMBER	SUPERVISOR SIGNATURE			
<p>ACTIVITY</p> <p> <input type="checkbox"/> CHEMICAL <input type="checkbox"/> MECHANICAL <input type="checkbox"/> SURVEY ONLY <input type="checkbox"/> CHEMICAL <input type="checkbox"/> MECHANICAL <input type="checkbox"/> SURVEY ONLY <input type="checkbox"/> CHEMICAL <input type="checkbox"/> MECHANICAL <input type="checkbox"/> SURVEY ONLY <input type="checkbox"/> CHEMICAL <input type="checkbox"/> MECHANICAL <input type="checkbox"/> SURVEY ONLY <input type="checkbox"/> CHEMICAL <input type="checkbox"/> MECHANICAL <input type="checkbox"/> SURVEY ONLY <input type="checkbox"/> CHEMICAL <input type="checkbox"/> MECHANICAL <input type="checkbox"/> SURVEY ONLY <input type="checkbox"/> CHEMICAL <input type="checkbox"/> MECHANICAL <input type="checkbox"/> SURVEY ONLY <input type="checkbox"/> CHEMICAL <input type="checkbox"/> MECHANICAL <input type="checkbox"/> SURVEY ONLY </p>							
JURISDICTION		LOCATION OR ROAD NAME/Km		COMMENTS			
JURISDICTION		LOCATION OR ROAD NAME/Km		COMMENTS			
JURISDICTION		LOCATION OR ROAD NAME/Km		COMMENTS			
JURISDICTION		LOCATION OR ROAD NAME/Km		COMMENTS			
JURISDICTION		LOCATION OR ROAD NAME/Km		COMMENTS			
JURISDICTION		LOCATION OR ROAD NAME/Km		COMMENTS			
JURISDICTION		LOCATION OR ROAD NAME/Km		COMMENTS			

Mechanical Treatments Mandatory Fields: Date of Treatment Agency Jurisdiction Site ID OR UTM Zone Easting & Northing Species Treatment Method Area Treated
 Chemical Treatments Mandatory Fields: All fields indicated in Mech. Treatments, PLUS Certified Applicator (and Number) Application Time Temperature Windspeed Name of Herbicide Application Rate Amount of Mix Used

FS 1265 2009/07
PAGE 1 OF 2



BRITISH COLUMBIA
The Best Place on Earth

Ministry of
Forests and Range

INVASIVE PLANT CHEMICAL & MECHANICAL TREATMENT RECORD



PCP No. 24-D-14725, Barvel 16637, Excerpt 20035, Minsite 28137
 Rastros 28137/26371, Vangajati 26593, Giazon 26648
 Roundup 13644, Tison 22K 9005, Translino 24084

<input type="checkbox"/> DATA ENTERED INTO WFP		ENTERED BY:		OTHER HERBICIDE		REGISTRATION #	
TREATMENT DATE	YR/MO/D	AGENCY	EMPLOYER	CERTIFIED APPLICATORS	CERT. NUMBER	OTHER APPLICATORS	CERT. NUMBER
RANGE UNIT	PASTURE	PAPER FILE ID	PIP NUMBER	SUPERVISOR SIGNATURE			
<p>ACTIVITY</p> <p> <input type="checkbox"/> CHEMICAL <input type="checkbox"/> MECHANICAL <input type="checkbox"/> SURVEY ONLY <input type="checkbox"/> CHEMICAL <input type="checkbox"/> MECHANICAL <input type="checkbox"/> SURVEY ONLY <input type="checkbox"/> CHEMICAL <input type="checkbox"/> MECHANICAL <input type="checkbox"/> SURVEY ONLY <input type="checkbox"/> CHEMICAL <input type="checkbox"/> MECHANICAL <input type="checkbox"/> SURVEY ONLY <input type="checkbox"/> CHEMICAL <input type="checkbox"/> MECHANICAL <input type="checkbox"/> SURVEY ONLY <input type="checkbox"/> CHEMICAL <input type="checkbox"/> MECHANICAL <input type="checkbox"/> SURVEY ONLY <input type="checkbox"/> CHEMICAL <input type="checkbox"/> MECHANICAL <input type="checkbox"/> SURVEY ONLY <input type="checkbox"/> CHEMICAL <input type="checkbox"/> MECHANICAL <input type="checkbox"/> SURVEY ONLY </p>							
JURISDICTION		LOCATION OR ROAD NAME/Km		COMMENTS			
JURISDICTION		LOCATION OR ROAD NAME/Km		COMMENTS			
JURISDICTION		LOCATION OR ROAD NAME/Km		COMMENTS			
JURISDICTION		LOCATION OR ROAD NAME/Km		COMMENTS			
JURISDICTION		LOCATION OR ROAD NAME/Km		COMMENTS			
JURISDICTION		LOCATION OR ROAD NAME/Km		COMMENTS			
JURISDICTION		LOCATION OR ROAD NAME/Km		COMMENTS			

Mechanical Treatments Mandatory Fields: Date of Treatment Agency Jurisdiction Site ID OR UTM Zone Easting & Northing Species Treatment Method Area Treated
 Chemical Treatments Mandatory Fields: All fields indicated in Mech. Treatments, PLUS Certified Applicator (and Number) Application Time Temperature Windspeed Name of Herbicide Application Rate Amount of Mix Used

FS 1265 2009/07
PAGE 1 OF 2



IAPP Site & Invasive Plant Survey Record







Entered into IAPP (YYYY-MM-DD):	By:	Assigned Site IDs <input type="checkbox"/> <i>recorded on this form:</i>
---	------------	--

Site Created Date (YYYY-MM-DD): *		Invasive Plant Survey Date (YYYY-MM-DD): * <small>(only if different from Site Created Date)</small>		Site ID: (assigned at IAPP data entry)	
Site Details					
Jurisdiction: * (see reverse for choices/codes)		District Lot Nr:		Range Unit:	
Site Paper File ID:		UTM Zone: *		UTM Easting: * (no initial zero)	
UTM Northing: * (7 digits)		Site Soil Texture:		coarse <input type="checkbox"/> fine <input type="checkbox"/> organic <input type="checkbox"/>	
Slope:		Aspect:		Elevation (m):	
Site Location (and directions how to get there):				Site Comments (anything else important /useful):	
Invasive Plant Survey Details					
Survey Agency: *		Employer:		Surveyor(s):	
Invasive Plants *	Area *	Distr. Code	Density Code	Survey Type *	Proposed Activity
Species name or code	Dimension or Ha	(see reverse for codes)		Cursory /Operational /Predse	Man Chem Bio
				C <input type="checkbox"/> O <input type="checkbox"/> P <input type="checkbox"/>	<input type="checkbox"/> <input type="checkbox"/> <input type="checkbox"/>
				C <input type="checkbox"/> O <input type="checkbox"/> P <input type="checkbox"/>	<input type="checkbox"/> <input type="checkbox"/> <input type="checkbox"/>
				C <input type="checkbox"/> O <input type="checkbox"/> P <input type="checkbox"/>	<input type="checkbox"/> <input type="checkbox"/> <input type="checkbox"/>
Site Image Details					
Date taken (YYYY-MM-DD):		Reference No. *		Perspective: * <small>(see reverse for codes)</small>	
				Image Comments:	

Site Created Date (YYYY-MM-DD): *		Invasive Plant Survey Date (YYYY-MM-DD): * <small>(only if different from Site Created Date)</small>		Site ID: (assigned at IAPP data entry)	
Site Details					
Jurisdiction: * (see reverse for choices/codes)		District Lot Nr:		Range Unit:	
Site Paper File ID:		UTM Zone: *		UTM Easting: * (no initial zero)	
UTM Northing: * (7 digits)		Site Soil Texture:		coarse <input type="checkbox"/> fine <input type="checkbox"/> organic <input type="checkbox"/>	
Slope:		Aspect:		Elevation (m):	
Site Location (and directions how to get there):				Site Comments (anything else important /useful):	
Invasive Plant Survey Details					
Survey Agency: *		Employer:		Surveyor(s):	
Invasive Plants *	Area *	Distr. Code	Density Code	Survey Type *	Proposed Activity
Species name or code	Dimension or Ha	(see reverse for codes)		Cursory /Operational /Predse	Man Chem Bio
				C <input type="checkbox"/> O <input type="checkbox"/> P <input type="checkbox"/>	<input type="checkbox"/> <input type="checkbox"/> <input type="checkbox"/>
				C <input type="checkbox"/> O <input type="checkbox"/> P <input type="checkbox"/>	<input type="checkbox"/> <input type="checkbox"/> <input type="checkbox"/>
				C <input type="checkbox"/> O <input type="checkbox"/> P <input type="checkbox"/>	<input type="checkbox"/> <input type="checkbox"/> <input type="checkbox"/>
Site Image Details					
Date taken (YYYY-MM-DD):		Reference No. *		Perspective: * <small>(see reverse for codes)</small>	
				Image Comments:	

* Indicates mandatory field - this form may be used for 2 sites, with their invasive plant surveys, and site images (if taken).

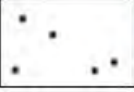
Some commonly used codes in IAPP:

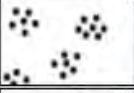
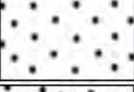
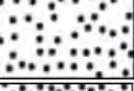
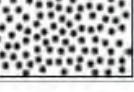
Distribution Code		
Code	Reference	Description
1		Rare individual, a single occurrence
2		Few sporadically occurring individuals
3		Single patch or clump of a species
4		Several sporadically occurring individuals
5		A few patches or clumps of a species
6		Several well-spaced patches or clumps of a species
7		Continuous uniform occurrence of well-spaced individuals
8		Continuous occurrence of a species with a few gaps in the distribution
9		Continuous dense occurrence of a species

Density Code		
Code	Reference	Description
1	Low	≤ 1 plant/m ²
2	Medium	2-5 plants/m ²
3	High	6-10 plants/m ²
4	Dense	> 10 plants/m ²

Jurisdiction Codes	
MFR	Ministry of Forests and Range
AH	Alaska Highway
HYDR	BC Hydro
BCR	BC Rail
BCTC	British Columbia Transmission Corp.
BNSF	Burlington Northern Santa Fe
CNR	CN Rail
CPR	CP Rail
DND	Department of National Defense
GL	Grazing Lease
FN	First Nations Reserves
MN	Mining Companies
MOT	Ministry of Transportation and Infrastructure
MOE	Ministry of Environment - <i>except Provincial Parks</i>
MOP	Municipality owned land
PIPE	Oil and Gas Companies
PNG	Pacific Northern Gas
PCAN	Parks Canada
P	Private Land
PP	Provincial Parks
MRD	Regional District owned land
TEL	Telus
TER	Terasen Gas Inc.
TRP	TransCanada Pipelines
WE	Westcoast Energy Inc.

* Indicates mandatory field - this form may be used for 2 sites, with their invasive plant surveys, and site images (if taken).

Chemical & Mechanical Monitoring Record



Entered into IAPP (YYYY-MM-DD):	By:	Assigned Monitoring IDs recorded on this form: <input type="checkbox"/>
------------------------------------	-----	--

Inspection Record I			
Inspection Date (YYYY-MM-DD): *	Site ID: *	Treatment ID: <small>(ID of the treatment being monitored)</small>	Monitoring ID: <small>(Assigned at Data Entry)</small>
Agency: *	Surveyor:		Monitoring Paper File ID:
Activity: * <input type="checkbox"/> Chemical Mon. <input type="checkbox"/> Mechanical Mon.	Compliance:		Efficacy Rating: (1-9)
Target Invasive Plant Species *	Comments:		
Inspection Record II			
Inspection Date (YYYY-MM-DD): *	Site ID: *	Treatment ID: <small>(ID of the treatment being monitored)</small>	Monitoring ID: <small>(Assigned at Data Entry)</small>
Agency: *	Surveyor:		Monitoring Paper File ID:
Activity: * <input type="checkbox"/> Chemical Mon. <input type="checkbox"/> Mechanical Mon.	Compliance:		Efficacy Rating: (1-9)
Target Invasive Plant Species *	Comments:		
Inspection Record III			
Inspection Date (YYYY-MM-DD): *	Site ID: *	Treatment ID: <small>(ID of the treatment being monitored)</small>	Monitoring ID: <small>(Assigned at Data Entry)</small>
Agency: *	Surveyor:		Monitoring Paper File ID:
Activity: * <input type="checkbox"/> Chemical Mon. <input type="checkbox"/> Mechanical Mon.	Compliance:		Efficacy Rating: (1-9)
Target Invasive Plant Species *	Comments:		
Inspection Record IV			
Inspection Date (YYYY-MM-DD): *	Site ID: *	Treatment ID: <small>(ID of the treatment being monitored)</small>	Monitoring ID: <small>(Assigned at Data Entry)</small>
Agency: *	Surveyor:		Monitoring Paper File ID:
Activity: * <input type="checkbox"/> Chemical Mon. <input type="checkbox"/> Mechanical Mon.	Compliance:		Efficacy Rating: (1-9)
Target Invasive Plant Species *	Comments:		

* indicates mandatory field

Daily Operations Record
Herbicide Use at Facilities
PMP#105-0983-16/21

Region: NI SI VI LM

BC Hydro Representative:

Contractor Name:

Pesticide Service License Holder No.

**Invoices will not be processed
 without correctly completed
 DOR's**



8475 – 128th Street

Invoice No:

Certified Applicator Name:

Signature:

Pesticide Applicator's Certificate No.

DATE (dd/mm/yy) TIME (hh:mm)	FACILITY NAME	TARGET SPECIES	HERBICIDE PRODUCT NAME	AMOUNT OF HERBICIDE PRODUCT USED	TREATED AREA (ha)	APPLICATION RATE (litres of product/ha)	HERBICIDE APPLICATION METHOD *	TEMPERATURE	PRECIPITATION (clear, overcast, light rain, rain)	LOCATION OF NOTIFICATION SIGNS / COMMENTS (e.g. reason for NTZ change, advice given, pest monitoring comments)
			PCP NUMBER	(litres) NOT tank mix NOT active ingred	NON-HERBICIDE AREA (ha)		NON-HERBICIDE METHOD **	WINDSPEED	WIND DIRECTION	
										<input type="checkbox"/> NA
										<input type="checkbox"/> NA
										<input type="checkbox"/> NA

* eg., basal bark, cut surface, backpack foliar, mechanical foliar, powerhose, etc.

** eg., weed trimming, hand-pulling, slashing, girdling, etc.

DORs must be **completed daily** for each pesticide application. The record must correspond with the PMP conditions, contractor invoicing, and herbicide product used. NOTE: Maps of treatment areas pertaining to these DORs must be included with highlighted treatment areas. Contractors must submit copies of maps and DORs to the BC Hydro Rep with each invoice or within 30 days of treatment, whichever is sooner. **Invoices will not be processed without correctly completed DORs.**

Injury thresholds: are expressed as a percentage of the total weed area that can be tolerated while still maintaining the integrity, security, and safety of the site. Thresholds vary from 0% to 10% depending on the area within each facility as outlined in BC Hydro's PMPs.

Monitoring: BC Hydro facilities are inspected and monitored for potential and existing weed problems each year before treatments occur to determine the necessity and timing of treatments. Contractors monitor on an ongoing basis for sufficient coverage of target weeds and vegetation and that injury thresholds are achieved.

Advice given to owner/manager is on signs posted at the main entry to the facility as follows: "Avoid contact with treated vegetation until herbicide has dried." Re-entry and date is specified on the sign. Describe location of every sign posted – i.e., facility main gate in NW corner.

Revised: Jan 30, 2014

Daily Operations Record

Herbicide Use on Transmission ROWs & Distribution Corridors

**Invoices will not be processed
without correctly completed
DOR's**



8475 – 128th Street

TRANSMISSION AND DISTRIBUTION CORRIDOR PMP: 105-0982-16/21

Region: NI SI VI LM

Invoice No:

BC Hydro Representative:

Certified Applicator Name:

Contractor Name:

Signature:

Pesticide Service License Holder No.

Pesticide Applicator's Certificate No.

DATE (dd/mm/yy) TIME (hh:mm)	CIRCUIT ID	TARGET SPECIES	HERBICIDE PRODUCT NAME	AMOUNT OF HERBICIDE PRODUCT USED	TREATED AREA (ha)	APPLICATION RATE (litres of product/ha)	HERBICIDE APPLICATION METHOD *	TEMPERATURE	PRECIPITATION (clear, overcast, light rain, rain)	LOCATION OF NOTIFICATION SIGNS / COMMENTS (e.g. reason for NTZ change, advice given, pest monitoring comments)	TREATMENT DETAILS
	TOWER/POLE NUMBERS		PCP NUMBER	(litres) NOT tank mix NOT active ingred	NON-HERBICIDE AREA (ha)		NON-HERBICIDE METHOD **	WINDSPEED	WIND DIRECTION		
										<input type="checkbox"/> NA	<input type="checkbox"/> 1 st Pass <input type="checkbox"/> 2 nd Pass <input type="checkbox"/> Re-treat
										<input type="checkbox"/> NA	<input type="checkbox"/> 1 st Pass <input type="checkbox"/> 2 nd Pass <input type="checkbox"/> Re-treat
										<input type="checkbox"/> NA	<input type="checkbox"/> 1 st Pass <input type="checkbox"/> 2 nd Pass <input type="checkbox"/> Re-treat
										<input type="checkbox"/> NA	<input type="checkbox"/> 1 st Pass <input type="checkbox"/> 2 nd Pass <input type="checkbox"/> Re-treat

* eg., basal bark, cut surface, backpack foliar, mechanical foliar, powerhose, etc.

DORs must be **completed daily** for each pesticide application. The record must correspond with the PMP conditions, contractor invoicing, and herbicide product used. Contractors must submit copies of maps and DORs to the BC Hydro Rep with each invoice or within 30 days of treatment, whichever is sooner. **Invoices will not be processed without correctly completed DORs.**

Injury thresholds: There is no tolerance for vegetation that could contact lines or disrupt service. The decision to initiate treatment is based solely on the presence of target vegetation that has the potential to grow into or fall onto electrical equipment as outlined in BC Hydro's PMPs. This vegetation was identified in the field by BC Hydro during visual assessment.

Monitoring: Contractors monitor on an ongoing basis for proper wraps (basal bark) and sufficient coverage of target foliage (foliar) or stump (cut surface).

Advice given is on signs posted at the treatment site as follows: "Avoid contact with treated vegetation for 24 hours from date and time of application until herbicide as dried." Re-entry time and date is specified on the sign. Provide product label information for advice on the number of days before a crop can be harvested safely. Describe location of every sign posted – i.e., reference tower or structure numbers, indicate whether on trails or roads etc.

FIXED RINSE STATION LOG

A. Equipment Information

Date:	Location:	Name:
-------	-----------	-------

B. Fixed Rinse Station – Equipment List

Equipment	Equipment	Equipment	
Trailer and spare tire	MSDS sheets	Station Instructions	Safety and Contact Information
10,000 L tank	Pressure rinser	Rinse hose and wand	Operating Manual
Tire iron	Fire extinguisher	Emergency Spill Kit	Traffic Cones
Safety gear:	Safety Glasses	Rain Coat	Eye rinse kit
Hard Hat	First Aid Kit – Level 1	Ear Plugs	Bottle of saline x 2

C. Fixed Rinse Station Use

Fill in the chart below: clearly write name/company name, date (mm/dd/yy), vehicle type (pickup, etc.), if a trailer was rinsed, and the time the equipment was used. Please make notes on station performance, equipment, spills, or the species of weeds that may be present.

Name	Date and Time	Vehicle Type	Reason for Rinse	Notes

Weed Report

Contact Information

Name: _____

Telephone: _____

Email: _____

Weed location

Land Location:

Civic Address:

GPS:

Located on: Crown Public Private Land

Details Regarding Infestation

Weed Species (if known):

Size of Infestation:

Additional Comments

SIGNAGE INSTALLATION

Date: _____

Surveyor Initials: _____

Sign Site Location:	GPS:	Access Directions:

Equipment List:

No.	Type	No.	Type
	sign posts		attachment hardware
	post driver		power tools

Set-up Procedure:

Action	Action (cont.)
Prepare site for installation	Check posts for stability
Install sign post	Check signs for solid attachment to posts
Attach sign (use at least two posts for larger signs)	

Sign Installation Details:

Site Location:	Sign Type:	Sign #	GPS Location:	Post installed	Sign installed

BARRIER INSTALLATION

GPS: Lat: _____
_Long: _____

Surveyor initials: _____

Access directions:

Equipment List:

No.	Type	No.	Type
	barrier		measuring tape
	stakes		

Set-up Procedure:

Action	Action (cont.)
Prepare site for installation	Measure and stake exclusion distances for barriers
Install barriers – coordinate with Wilson Concrete	(estimated at 6'8" for trucks and 5'6" for cars)

Barrier Installation:

Location:	Barrier #	GPS:	Barrier measured	Barrier installed

SIGNAGE AND BARRIERS MAINTENANCE

Date: _____ Surveyor Initials: _____

Sign Maintenance:

Location	Sign #	Condition	Location	Sign #	Condition

Condition	Code
sign is in installed condition	1
sign shows slight wear or damage	2
sign is heavily worn or damaged	3
sign is illegible or needs replacing	4

Condition	Code
barrier is in installed condition	1
barrier shows slight wear or damage	2
barrier is heavily worn or damaged	3
barrier needs replacing	4

Barrier Maintenance:

Location	Barrier #	Condition	Location	Barrier #	Condition

Signage/Barrier Installation – Form Procedure

Date: fill in the date as dd/mm/yy

Surveyor Initials: write the initials of those involved in installation

Sign Site Location: name of site where signs will be installed (wash station location/land parcel)

- **GPS:** write latitude and longitude of site for signs
- **Access Directions:** write any brief notes needed to find the site

Equipment List: check this equipment list before beginning installation

Set-up Procedure: follow these steps for installation

Sign/Barrier Installation Details: fill out all fields for sign/barrier information

- **Site Location:** name of the site (wash station location/land parcel)
- **Sign Type:** sign contents
- **Sign #:** number of signs
- **GPS Location:** latitude and longitude of sign location
- **Post/Sign installed:** check when support post/sign has been installed
- **Barrier measured/installed:** check when barrier distance has been marked and installed

Signage/Barrier Maintenance – Form Procedure

Date: fill in the date as dd/mm/yy

Surveyor Initials: write the initials of those involved in installation

Site/Barrier Maintenance Description

- **Location:** enter the location of the sign/barrier
- **Sign/Barrier #:** enter the appropriate number of the sign/barrier
- **Condition:** enter the appropriate code for the condition of the sign/barrier

BASELINE SURVEY

Site Name: _____

A. Site Information

Date:	Surveyor Name:	Resources Present:
Site Type: Field, Road, Pasture, ROW, other	Location:	Management units (if applicable):
		Soil Texture:

B. Site Map

Features GPSed: Yes / No	Features Field Marked: Yes/No	Infestation Center(s) Latitude: Longitude:	Baseline Photos Taken: Targets: Yes / No Overview: Yes / No
Features: Treatment Perimeter - • - • - • - • - • - Road ===== PFZ - //////////////// Wetland (≡) Stream - → → → → House ^ Wellsite [o]			

C. Walkthrough

Patch #																		
Track #																		
Plot #																		
Species																		
Count																		
% Cover																		
Growth Stage																		

Patch #																	
Track #																	
Plot #																	
Species																	
Count																	
% Cover																	
Growth Stage																	

Dispersed weeds found outside dense weed patch area: Y / N

D. Transect Sampling for Dispersed Weed Populations

Pixel #	Pixel Length:				Pixel #	Pixel Length:			
Start:	Lat:		Long:		Start:	Lat:		Long:	
End:	Lat:		Long:		End:	Lat:		Long:	
Species					Species				
Count					Count				
% Cover					% Cover				
Growth Stage					Growth Stage				

Pixel #	Pixel Length:				Pixel #	Pixel Length:			
Start:	Lat:		Long:		Start:	Lat:		Long:	
End:	Lat:		Long:		End:	Lat:		Long:	
Species					Species				
Count					Count				
% Cover					% Cover				
Growth Stage					Growth Stage				

Pixel #	Pixel Length:				Pixel #	Pixel Length:			
Start:	Lat:		Long:		Start:	Lat:		Long:	
End:	Lat:		Long:		End:	Lat:		Long:	
Species					Species				
Count					Count				
% Cover					% Cover				
Growth Stage					Growth Stage				

Pixel #	Pixel Length:				Pixel #	Pixel Length:			
Start:	Lat:		Long:		Start:	Lat:		Long:	
End:	Lat:		Long:		End:	Lat:		Long:	
Species					Species				
Count					Count				
% Cover					% Cover				
Growth Stage					Growth Stage				

Pixel #	Pixel Length:				Pixel #	Pixel Length:			
Start:	Lat:		Long:		Start:	Lat:		Long:	
End:	Lat:		Long:		End:	Lat:		Long:	
Species					Species				
Count					Count				
% Cover					% Cover				
Growth Stage					Growth Stage				

E. Noxious Weed Species Present and Dominant Growth Stage:
Seedling, Early Growth, Flowering/Fruiting, Skeleton

Noxious Weed Species	Dominant Growth Stage:	Noxious Weed Species	Dominant Growth Stage:

Notes: (weeds present outside parcel boundary, comments on vegetation, etc.)

Data Entered On:

Baseline Survey – Form Procedure

Site Name: write land parcel name

Site Information

- **Date:** write the date dd/mm/yy
- **Surveyor Name:** write surveyor(s) name
- **Resources present:** write resources as found in survey pre-work
- **Site Type:** note site type from listed options, detailing site if 'other' selected
- **Location:** write a brief description of survey location
- **Management units:** enter units of management, if large parcel has been divided
- **Soil Texture:** write determined soil texture

Site Map: draw important features on site, weed infestations, and applied pesticide areas

- **Features GPSed:** note whether GPS locations taken of site features
- **Features Field Marked:** note whether site features marked in the field
- **Infestation Centre(s):** note latitude and longitude of weed infestation centre
- **Baseline Photos Taken:** note whether photos taken of targets and overview
- **Features:** detail important site features using the symbols in the legend

Walkthrough:

- **Patch #:** write number of patch from walkthrough
- **Track #:** write number of GPS track as started from walkthrough
- **Plot #:** write number of plot within weed patch
- **Species:** write identified weed species as per weed codes
- **Count:** estimate weed population by species
- **% Cover:** estimate percentage cover of population by species
- **Growth Stage:** determine dominant growth stage of weeds by species
- **Dispersed weeds found outside dense weed patch area:** circle Y if transect sampling necessary

Transect Sampling for Dispersed Weed Populations

- **Pixel:** write number of pixel on transect
- **Pixel Length:** write measured length of the pixel from GPS
- **Start:** record lat./long. of pixel start point
- **End:** record lat./long. of pixel end point
- **Species:** write the name of weed species present in the pixel as per weed codes
- **Count:** estimate weed population by species
- **% Cover:** estimate percentage cover of population by species
- **Growth Stage:** determine dominant growth stage of weeds by species

Noxious Weed Species Present and Dominant Growth Stage

- **Noxious Weed Species:** write the name of weed species present as per weed codes
- **Dominant Growth Stage:** determine dominant growth stage of weed species

Notes: make any relevant notes not covered by other baseline survey fields

Data Entered On: update form with the day when field form is entered – dd/mm/yy

Baseline Survey Protocol

Pre-survey work:

- Identify resources in the area to be surveyed:
- On site maps, mark resources in area
- list of resources in survey areas will be provided in all field books.
- If the area is large, divide into smaller management areas (units).

Notes on Weed Identification for Surveys:

All species included in the regional and provincial list of noxious weeds will be recorded in the baseline survey (see Appendix 1). The following species are of particular concern in this region:

Canada Thistle	<i>Cirsium arvense</i>
Scentless Chamomile	<i>Matricaria perforate</i>
Spotted Knapweed	<i>Centaurea maculosa</i>
Oxeye Daisy	<i>Leucanthemum vulgare</i>

- If a weed species can't be confidently identified at the survey site, a representative sample specimen (a complete plant with flowering structures, if practical) will be taken for office identification. The site location and date of the sample specimen will be noted.
- All stages of plant growth will be included in the survey. Special attention will be given to check for seedlings and basal rosettes present at the survey site.
- Dominant plant growth stages:
 - Seedling – plant has less than 3 sets of true leaves
 - Early growth – plant has more than 3 sets of true leaves and does not have flowering buds
 - Flowering/Fruiting – plant has developed flowering buds
 - Skeleton – plant has no visible living tissue

Baseline Survey Equipment Used:

- GPS handset
- field plant identification references
- field baseline survey forms
- measuring tape (at least 5m)

Baseline Survey Methods:

On arrival to a site, the following information will be gathered for the site information:

- Site name – parcel name in full

- Date – day/month/year
- Client – assumed as BC Hydro
- Photos - taken of representative views of the site conditions and general overview
- Resources present – taken from pre-survey information
- Management units (if applicable) – units A-Z
- Site type – field, road, pasture, R.O.W., other
- Soil texture - soil texture will be determined from a sampling from at least three different site locations to the categories stated in the “Field Manual for Describing Terrestrial Ecosystems” (2010), section 9.19.

Start a GPS track, and walk the boundaries of the parcel to generate a complete boundary for the survey area.

Mark the GPS locations of important features on the site, both natural and constructed.

- Point mapping – such as climate stations and wells
- Line mapping – such as fences, streams, drainage channels, pipelines
- Polygon mapping – parcel edges, dugouts, buildings

Site map should include:

Boundaries

General cardinal direction

Special features

Location of listed resources

Walkthrough

The first survey will be a walkthrough to locate large weed patches that will be sampled intensively for density and cover, and to determine if dispersed weed populations exist between the identified patches.

- A walkthrough will be performed to locate large patches of weeds and to define the boundaries of these weed patches.
- Mark edges of patches with a saved GPS track around the entire edge. Patch edge is defined as an area that has weed individuals separated by more than 2.5 m from each other.
 - The GPS track will have a two-part label, including the property code), the patch number that it represents.
- Perform a sampling of individual weed patches which will follow a stratified-random sampling method. Evenly distribute multiple 1m by 1m plots within the patch to get sampling of patch density and cover.

Mark the following information:

- a) weed species identified in plot, using standardized codes (see list).
- b) count of individuals by species.
- c) percentage cover of weeds by species in the plot.
- Make a note if dispersed individuals are found outside the patch area. If there are dispersed weeds separated from the large patches, a transect sampling is necessary.

Transect Sampling (Dispersed Weed Populations)

If dispersed weed individuals are found outside patch boundaries, perform a larger scale transect sampling (stratified-continuous method) of areas not covered by the intensive sampling in the weed patches.

- Align transects to various factors such as dominant parcel edge direction and slope. The most important factor is maintaining parallel transect lines.
- Turn on the GPS track for the entire transect length
- Use compass and/or GPS to maintain parallel during sampling.
- Set transect lines 50 m apart from each other.
- Area to be surveyed from the transect lines is 5 m on either side of transect, making a total of 10 m surveyed along the transect line.

Weed occurrences are grouped into population pixels, based on a maximum proximity of 5 m between individual plants. There will be a start point and an end point of a population pixel. The pixel starts at the first weed encountered. The pixel ends 5m past the last identified weed individual. Each point will be recorded in the GPS (see Figure 1).

- This point will have a three part label, including the property code the pixel number that it represents, and whether the point is the start or the end of the pixel
 - For example: the bounds of Area 1, pixel 1 would be labelled as:
 - Start Point: AR1-P1-st
 - End Point: AR1-P1-en
- Pixels are assumed to occupy an area defined by the 10 m width of transect and the distance measured between the start and end points of the weed population.
- If a single weed individual is identified, and there are no other weeds within 5 m along the transect, then the end point would be located 5 m past the lone weed, giving that pixel a 5 m by 10 m area.



Figure 1: Transect Line and Pixel Definition Example

For each pixel of weed occurrence, mark the following information:

- a) pixel length (x m of transect length between start and end points)
- b) latitude and longitude of start point
- c) latitude and longitude of end point
- d) weed species present in pixel
- e) count of individuals by species in pixel
- f) percentage cover of weeds by species in pixel

Notes on sampling (see Figure 2): (1) - If a pixel continues to a point where the transect hits the survey area edge, the pixel is considered to come to an end point. An additional pixel is started when the transect line re-ori-ents and heads away from the survey edge.

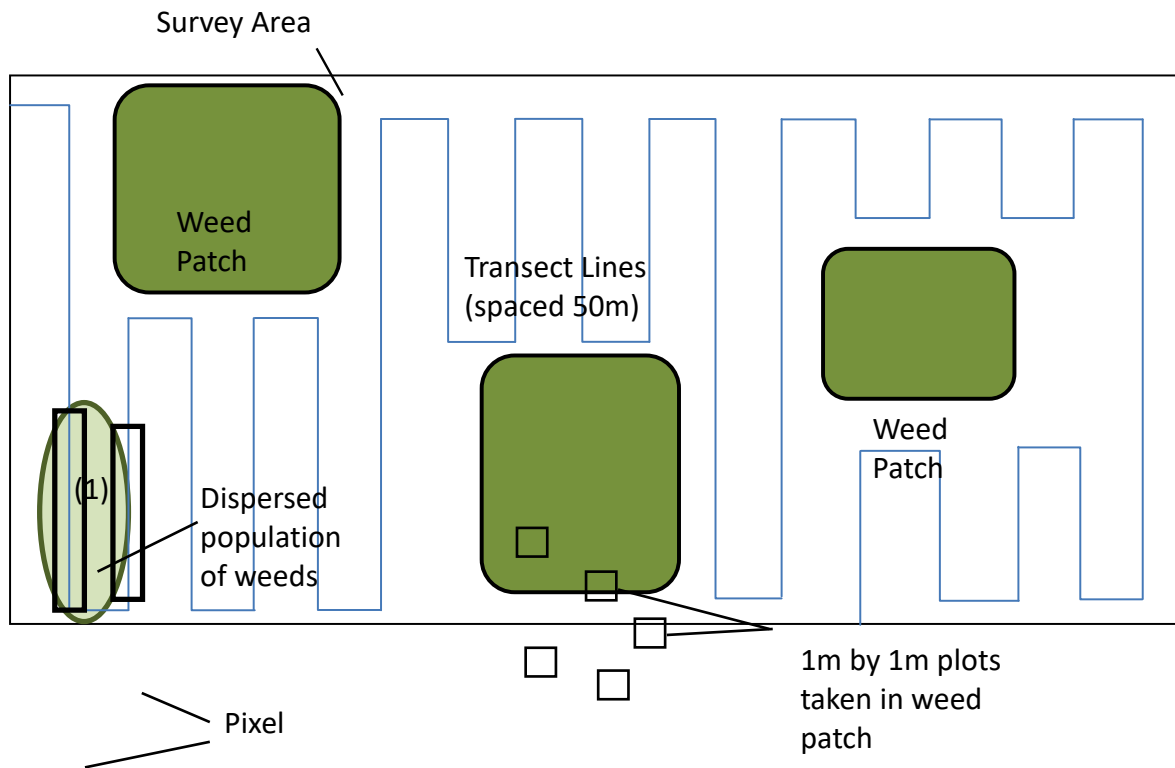

Figure 2 - Example of Surveying Methods - Total survey area shown with the layout of transects in relation to dense weed patches

Variation of Baseline Survey Methods for Access Corridors and Small Scale Survey Areas:

The objective of the small scale survey is to create a meaningful map of weed populations and distribution in the surveyed area. First, the small-scale survey area will be sampled by a walkthrough to find dense weed populations and then a stratified-continuous transect to find dispersed weed distribution and density. Next, a walkthrough and stratified-continuous transect will be completed from the access point to end destination to find weed populations. Another transect will be laid out on the other side of the access corridor from the first line transect (land not controlled by BC Hydro will not be surveyed).

Baseline Surveying in Small Scale Areas

A walkthrough will be performed to locate large patches of weeds and to define the boundaries of these weed patches.

- Mark edges of patches with a GPS track around the entire edge. Patch edge is defined as an area that has weed individuals separated by more than 2.5 m from each other.
- Perform a sampling of individual weed patches which will follow a stratified-random sampling method. Distribute evenly, multiple 1 m by 1 m plots within the patch to get sampling of patch density and cover:
 - Identify weed species in plot, using standardized codes (see Appendix 1).

- Count the number of individual plants.
- Estimate the percentage cover of each species in the plot.
- Make a note if dispersed individuals are found outside the patch area.
- If there are dispersed weeds separated from the large patches, a transect sampling is necessary.

If dispersed weed individuals are found outside patch boundaries, perform a transect sampling (stratified-continuous method) of areas not covered by the access corridor transect.

- Align transects to various factors such as dominant parcel edge direction or slope. The most important factor is maintaining parallel transect lines.
- Use compass and/or GPS to maintain parallel during sampling.
- Set transect lines at least 50 m apart from each other in small areas.
- Area to be surveyed from the transect lines is 5 m on either side of transect, making a total of 10 m surveyed along the transect line.
- Use the same data point logging and labelling system as with large scale surveying

Weed occurrences are grouped into population pixels, based on a maximum proximity of 5m between individual plants. There will be a start point and an end point of a population pixel. The pixel starts at the first weed encountered. The pixel ends 5m past the last identified weed individual. Each point will be recorded in the GPS (see Figure 1).

- This point will have a three-part label, including the property code , the pixel number that it represents, and whether the point is the start or the end of the pixel
 - For example: the bounds of Area 1, pixel 1 would be labelled as:
 - Start Point: AR1-P1-st
 - End Point: AR1-P1-en
- Pixels are assumed to occupy an area defined by the 10 m width of transect and the distance measured between the start and end points of the weed population.
- If a single weed individual is identified, and there are no other weeds within 5 m along the transect, then the end point would be located 5m past the lone weed, giving that pixel a 5 m by 10m area.

Baseline Surveying on Access Corridors

A walkthrough will be performed to locate large patches of weeds and to define the boundaries of these weed patches. The area covered by the access corridor survey will start at the access point and end 100m from the climate station.

- Mark edges of patches with a GPS track around the entire edge. Patch edge is defined as an area that has weed individuals separated by more than 2.5 m from each other.
- Perform a sampling of individual weed patches which will follow a stratified-random sampling method. Distribute multiple 1m by 1m plots within the patch to get sampling of patch density and cover:
 - Identify weed species in plot, using standardized codes (see Appendix 1).
 - Count the number of individual plants.
 - Estimate the percentage cover of each species in the plot.
- Make a note if dispersed individuals are found outside the patch area.
- If there are dispersed weeds separated from the large patches, a transect sampling is necessary.

Lay out transects (stratified-continuous method) to sample access corridors.

- Align transects to road direction to cover at least 25 m of area from the road edge, or to the property boundary. The desired number of transects is two, and the minimum number is one if constrained by a property boundary (see Figure 3).
- Use compass and/or GPS to maintain parallel during sampling.
- Set transect lines at least 5 m from road edge, and keep transects at least 15 m from each other.
- Area to be surveyed from the transect lines is 5 m on either side of transect, making a total of 10 m surveyed along the transect line.
- Use the same data point logging and labelling system as with large scale surveying

Weed occurrences are grouped into population pixels, based on a maximum proximity of 5m between individual plants. There will be a start point and an end point of a population pixel. The pixel starts at the first weed encountered. The pixel ends 5m past the last identified weed individual. Each point will be recorded in the GPS (see Figure 1).

- This point will have a three-part label, including the property code, the pixel number that it represents, and whether the point is the start or the end of the pixel
 - For example: the bounds of Area 1, pixel 1 would be labelled as:
 - Start Point: AR1-P1-st
 - End Point: AR1-P1-en
- Pixels are assumed to occupy an area defined by the 10 m width of transect and the distance measured between the start and end points of the weed population.
- If a single weed individual is identified, and there are no other weeds within 5 m along the transect, then the end point would be located 5m past the lone weed, giving that pixel a 5 m by 10 m area.

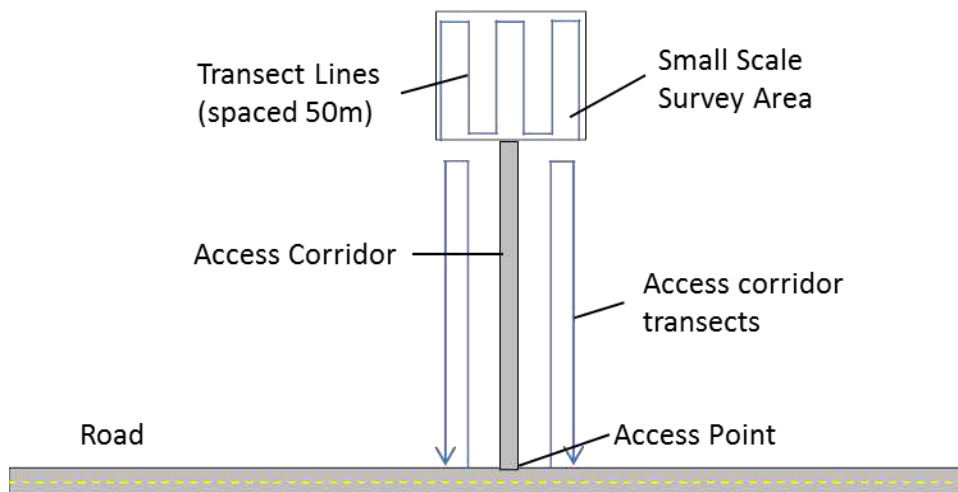

Figure 3 - Example of Surveying Methods beside Small Scale Survey Areas and Access Corridors

Noxious Weed Codes: Provincial and Peace River Region

Provincial Noxious Weed Code		Peace River Region Noxious Weeds		
Species	Code	Common Name	Latin Name	Species Code
annual sow thistle	aST	Common Crupina	<i>Crupina vulgaris</i>	CC
Canada thistle	CT	Diffuse Knapweed	<i>Centaurea diffusa</i>	DK
common crupina	CC	Dodder	<i>Cuscuta spp.</i>	Ddr
Dalmatian toadflax	DT	Hound's-tongue	<i>Cynoglossum officinal</i>	HT
diffuse knapweed	DK	Giant Burdock	<i>Arctium spp.</i>	Bk
dodder	Ddr	Jointed Goatgrass	<i>Aegilops cylindrical</i>	JG
gorse	Grs	Leafy Spurge	<i>Euphorbia esula</i>	LS
hound's-tongue	HT	Rush Skeletonweed	<i>Chondrilla juncea</i>	RS
jointed goatgrass	JG	Spotted Knapweed	<i>Centaurea maculosa</i>	SK
leafy spurge	LS	Tansy Ragwort	<i>Senecio jacobaea</i>	TR
perennial sow thistle	pST	Velvetleaf	<i>Abutilon theophrasti</i>	VL
purple nutsedge	PN	Yellow Starthistle	<i>Centaurea solstitialis</i>	YS
rush skeletonweed	RS	Green Foxtail	<i>Setaria viridis</i>	GF
scentless chamomile	SCh	Kochia	<i>Kochia scoparia</i>	Koc
spotted knapweed	SK	Oxeye Daisy	<i>Chrysanthemum leucanthemum</i>	OD
tansy ragwort	TR	Tartary Buckwheat	<i>Fagopyrum tataricum</i>	TB
velvetleaf	VL	Russian Thistle	<i>Salsola kali</i>	RT*
wild oats	WO	Perennial Sow Thistle	<i>Sonchus arvensis</i>	pST
yellow nutsedge	YN	Common Toadflax	<i>Linaria vulgaris</i>	CoT*
yellow starthistle	YS	Dalmatian Toadflax	<i>Linaria dalmatica</i>	DT
yellow toadflax	YT	Scentless Chamomile	<i>Matricaria maritime</i>	SCh
		Annual Sow Thistle	<i>Sonchus oleraceus</i>	aST
		Wild Mustard	<i>Sinapsis arvensis</i>	WM
		Night-flowering Catchfly	<i>Silene noctiflora</i>	NfC
		White Cockle	<i>Lynchis alba</i>	WCo
		Wild Oats	<i>Avena fatua</i>	WO
		Cleavers	<i>Galium aparine</i>	Cvr
		Quackgrass	<i>Agropyron repens</i>	QG

GRASS SEEDING APPLICATION AND ASSESSMENT

Date: _____ Surveyor Initials: _____

Site Location: _____ Site Area: _____

GPS Location: lat. _____ long. _____

Site Map:

Applied Areas GPSed: Y / N

Site Conditions:

Site Type: Field, Pasture, ROW, other	Moisture Level: High / Moderate / Low
Site Slope and Aspect (°):	Soil Texture:
Standing water present (High) Y / N	Site adjacent to water body Y / N
Seedbed Prepared Y / N	Photos Taken: Pre-Seed Post-Seed Y / N Y / N
Intended Pasture/Rangeland Use Y / N	

Grass Type Used:

	Grass Type	Seeding - Amount Used (kg)	Poor Growth Re-Seeding – Amount Used (kg)

Equipment Used:

Quad Seeder				
Hand Seeder				
Drag				

Grass Seeding Application and Assessment – Form Procedure

Date: write date as dd/mm/yy

Surveyor Initials: write surveyor(s) name

Site Name: write the name of the land parcel

Site Location: write the approximate location of the land parcel

GPS Location: record the lat. and long. of the area to be seeded

Site Map: draw important features on site and applied grass seed areas

- **Applied Areas GPSed:** circle Yes or No if GPS locations taken of seeded areas

Site Conditions:

- **Site Type:** circle appropriate site type, or detail the type is 'other' is selected
- **Moisture Level:** select High, Moderate, Low
- **Site Slope and Aspect:** write down the site slope and aspect in degrees
- **Soil Texture:** determine soil texture from baseline survey, or key out texture on site
- **Standing water present:** circle Yes or No if standing water, or evidence of recent standing water found
- **Site adjacent to water body:** circle Yes or No if a water body is adjacent
- **Seedbed prepared:** circle Yes or No if the seedbed was prepared before seeding
- **Photos Taken:** circle Yes or No if photos are taken of the area to be seeded.
- **Flare Stack Present Near Site:** circle Yes or No if a flare stack is present
- **Intended Pasture/Rangeland Use:** circle Yes or No is the area is intended for pasture or rangeland.

Grass Type Used:

- **Grass Type:** write type/species of grass seed applied
- **Seeding – Amount Used (kg):** write amount of grass seed used
- **Poor Growth Re-seeding – Amount Used (Kg):** write down amount of grass seed used in a previously treated area (seed applied due to poor establishment)

Equipment Used: check the boxes beside any equipment was used, and add other equipment that was used

Grass Seeding Methods:

This seeding method will consist of multiple parts to successfully establish grass populations in areas disturbed by engineering activities, as well as other activities. On arrival, site information and important features will be noted. First an application of grass seeds will be completed, and then a post-seeding inspection.

Pre-seed Methods:

Seeding will occur on any site where there is significant ground disturbance. Significant ground disturbance will be considered for the purposes of this method as exposed soil and little to no vegetation. Re-vegetation will not take place until all engineering activities are complete for that area. Severely dry meteorological conditions will be considered when timing seeding. Low-growth grass should be planted at sites with a flare stack to reduce fire hazard. Sites that are closer to water bodies and wetter, a moisture tolerant species of grass should be used.

Determine the type of equipment to use as determined by site moisture conditions:

- Large area, compacted and/or dry conditions - Quad seeders
- Small area, wet conditions where further disturbance will be an issue - Hand Seeders
- Quad mounted Drags
- Apply grass seed according to supplier's specifications

Post-seed Methods:

Once grass is seeded, avoid using ATVs or other vehicles on the site.

- Take photos of site to show progress of establishment and for future reference
- Record type of grass used, area seeded, site conditions and any other pertinent information
- Assess grass establishment – reseed if necessary or seed different type of grass

Appendix L Western Toad Management Procedure

Site C Western Toad Management Procedure

This management procedure is applicable only during construction on access roads, the transmission line right-of-way, and areas within 250 m of wetlands. However, in all construction areas impacts to amphibians must be mitigated as described in §4.17 of the [Site C CEMP](#), including through the implementation of barriers, setback buffers, and salvage and relocation, as appropriate and at the direction of a Qualified Environmental Professional.

Core Period: June 01 to August 15 – At this time juvenile western toads (**Figures 1, 3, and 4**) disperse from breeding sites (shallow margins of lakes, ponds, or wetlands) into foraging sites (other wetlands, riparian areas along streams, or upland sites). Large numbers of toads might be encountered on roads and at work sites. Juvenile western toad observations ≥ 10 individuals have occurred within the Project area from June 1 until August 15; the anticipated duration for western toad dispersal is approximately 11 weeks – the “core dispersal period”.

During the core dispersal period, a Qualified Environmental Professional (QEP) **must** survey:

- all Project Access Roads prior to crews driving to site,
- all Project Access Roads prior to the first daily site delivery; and
- all daily Work Sites before work commences.

Caution Periods: April 01 – May 31; August 16 – September 30 – Adult western toads (**Figure 2**) and juveniles (**Figure 1**) may occur on Access Roads and at Work Sites during their “breeding period” or “foraging period.”

The breeding window is when adults start to move from hibernation areas to breeding sites (shallow margins of lakes, ponds, or other wetlands). Toads often move at night, when temperatures are cooler, and especially after a rainfall. The breeding window coincides with days where the minimum temperature doesn't drop below 0°C AND the maximum temperature is above 10°C. In the Project area, the breeding period is April 01 – May 31.

The foraging window is when adults and juveniles move from breeding sites to foraging areas to prepare for hibernation. As with the breeding window, toads tend to be more active at night, especially following a rainfall. Toads can be found foraging year-round, but the key foraging period is August 16 – September 30.

During the caution period, before any work starts, the contractor **must** contact the QEP to provide the work location and start date. The contractor's QEP **must** conduct an Access Road / Work Site sweep to determine if toads are likely to be present, before work starts. The contractor's QEP can give an “all clear” window for up to one week after this sweep during the caution period. The contractor's QEP **must** be notified to re-assess the area if one week or more has passed since the previous “all clear.”

Hibernation Period: October 01 – March 31 - Western toads are not anticipated to be on work sites or roads.



Figure 1. Juvenile western toads are small and can be difficult to detect if dispersal is limited to a few individuals.



Figure 2. Adult western toad traveling to breeding site.

Figure 3. Sub-adult western toad.



Figure 4. Mass dispersal event of juvenile western toads.

Site C Western Toad Management Procedure

This management procedure outlines how BC Hydro and its contractors will remain compliant with EAC conditions 16 and 19 pertaining to western toads, a federally and provincially listed species at risk. It applies only during construction on access roads, transmission line rights-of-way, and off-site areas within 250 m of wetlands. However, all construction activities must mitigate for amphibians as described in §4.17 of the [Site C CEMP](#).

A QEP with western toad survey experience, employed by the contractor, must survey for toads:

- before any work along project access roads during the core dispersal period (June 01 to August 15).
- at work sites within the transmission line right-of-way (towers, roads, laydown, pull-sites, offices, staging areas) and any project-related off-site areas within 250 metres of wetlands.
- along existing project access roads adjacent to wetlands during the caution period (breeding and foraging windows, April 01 – May 31 and August 16 – September 30, respectively).

On the direction of the contractor's QEP, contractors may be required to alter their schedule.

Access Road and Work Site Sweep Methods

During the core dispersal period, and during the caution periods (April 01 - May 31 and August 16 - September 30), the contractor's QEP must conduct a road and work site sweep prior to heavy traffic use on access roads, and construction activities at transmission towers and transmission access routes. Once the road and work site sweeps have finished, the contractor's QEP will determine if western toads are at risk of direct mortality. If there is determined to be no risk to dispersing toads, work will be allowed to commence.

Road sweeps must be conducted by vehicle travelling at 35-55 km/h (as appropriate given QEP experience and road/weather conditions) with the contractor's QEP in the passenger seat looking for dispersing western toads on the road and road verges. Road sweeps can commence at dawn using headlights on low beam for illumination (see [RISC Standard for Pond Breeding Amphibians](#)).

Work site and adjacent wetland area sweeps / searches must be conducted on foot by the contractor's QEP using a search pattern (zig-zag, grid or transect) that considers observability, terrain, searcher safety and search area coverage. Maximum survey effort is 1 ha/hour time constrained searches, as per the [RISC Standard for Pond Breeding Amphibians](#).

The contractor's QEP will maintain awareness of best management practices for western toads, including the BC [Guidelines for Amphibians during Development](#) and [BMP - Amphibian and Reptile Salvages](#) and revisions.

Toad Sweep Crew Tool Kit

2 x 30km/h road signs, 20 x 0.5 m stakes, 3 x hammer/mallet, 200 m landscaping fabric (minimum 0.5 m width), 1 x box cutter, 2 x shovel, 5 x pit trap buckets (2 gal, ~9" diameter, ~9" depth), 2 x bucket lids with holes (for translocation), 100 x nitrile gloves (various sizes), 5 x work gloves, 1 L unscented bleach, 4 gallon water.

Stop Work Procedure

All road and work site sweeps must be conducted by the contractor's QEP. If dispersing western toads are confirmed within 20 m of access roads or construction, the contractor's QEP must halt traffic and construction activities at the dispersal site and initiate the steps described before work recommences. Qualified personnel under the direction of the contractor's QEP will install temporary barrier fences along the road or around construction at the dispersal site. Barrier fences will be of UV stabilized material, woven or solid to prevent small toads passage, and 0.5 m high and curved or L-shaped at the top (with the fence lip facing away from the road) to prevent toads from climbing over the fence. Barrier fences must be arranged in a wedge or zig-zag pattern to funnel amphibians into traps and must extend 50 to 100 m beyond the last trap at either end of the fence. Trapped toads will be translocated away from the road or work site in buckets to continue dispersal (see "Translocation"). Personnel requirements depend on the size and spatial extent of the dispersal. Speed restrictions of 30 km/h in the area 50 m either side of the dispersal site must be applied and maintained for the duration of the dispersal event. A sweep must confirm dispersing western toads have vacated the area before the contractor's QEP can approve the commencement / re-commencement of construction at the dispersal site, and lift the speed restriction.

Translocation

If dispersing western toads are observed on any roads, or at tower construction sites, the contractor's QEP will determine the direction of dispersal. All toads potentially affected by traffic or construction must be captured, translocated, and released by the contractor's QEP; in the direction of dispersal and to a safe area within 200 m (and at least 50 m from) the capture site. Translocated individuals will not be placed in any specific habitat type, but sub-optimal habitats (e.g., drill pads, rock outcrops) will be avoided. During translocations the contractor's QEP must maintain hygiene when handling amphibians, including following established procedures to prevent the spread of amphibian chytrid fungus, as described below. If individuals are translocated >200 m from point of capture, survival monitoring must be completed by the contractor's QEP as per *Wildlife Act* permit FJ16-226024.

If a mass dispersal (>100 individuals during a 24-hour period) requiring relocation of toads (as above) is identified over three consecutive years in the same location, consideration will be given to installing a permanent crossing structure to separate dispersing toads from traffic. Crossings will be appropriately designed culverts or structures achieving separation, and including well-maintained guidance fencing to direct toads into the structure, see [Guidelines for Amphibians during Development](#) (pg. 23). Such mitigation will be directed by the QEP and BC Hydro's Representative and will be an extra to the contract, to be managed via the contract change process.

Disinfectant and Hygiene

Handlers must wear clean, new vinyl or nitrile gloves during salvages, as per BC's [Standard Operating Procedures: Hygiene Protocols for Amphibian Fieldwork](#). Gloves must be changed when moving to another translocation site. Buckets used for transferring individuals must be disinfected using a household bleach and water mixture at 32 ml / 1 litre of water (or 3.5 cups bleach to one tall bucket / 25 litre of water).

Western Toad Caution Period
 (April 1 – May 31, August 16 – September 30)

Weekly sweeps, before travelling to site, and before any work commences

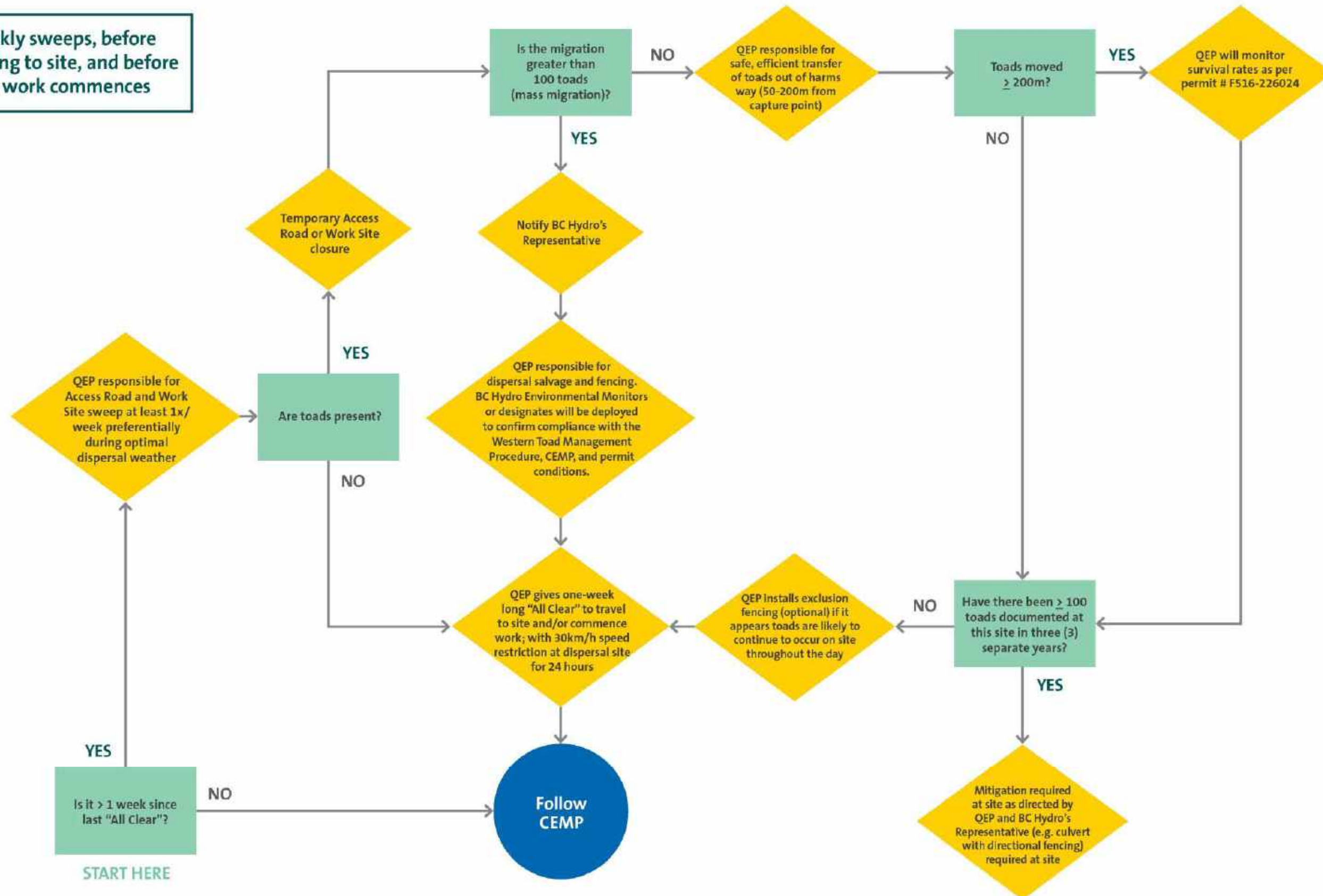

Western Toad Core Dispersal Period
(June 1 – August 15)

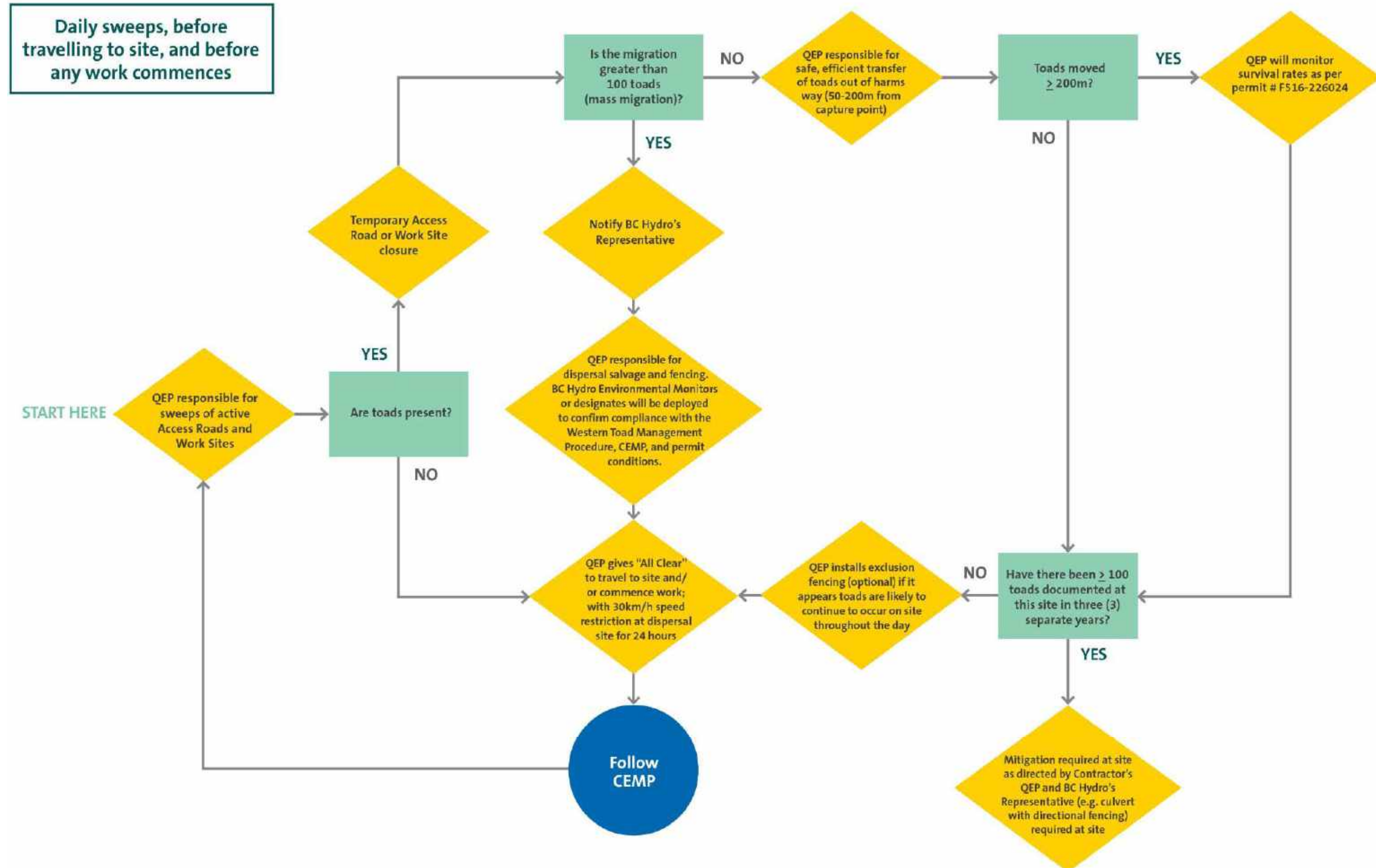

Appendix M Weekly Environmental Monitoring Report Template



**Site C Clean Energy Project
Weekly Environmental Monitoring Report
EXAMPLE**

Introduction

This EXAMPLE weekly environmental monitoring report provides a recommended standardized format that includes examples of the types of information that should be included to document compliance with the Project's overarching CEMP and a generic contractor's EPP(s).

This EXAMPLE assumes that a contractor's work involves activities governed under multiple EPPs. The EXAMPLE is intended to be scalable upwards for work governed under many EPPs or downwards for work governed under one EPP. The recommended general layout is for an overarching summary section following by chapters that each describe the findings relating to a specific EPPs, grouped by their CEMP theme, followed by appendices that provide copies of collected data.

This EXAMPLE first provides a summary of explanatory notes, then provides example report content.

Cover Page(s) Section

The Cover Page(s) Section should contain the following information:

- Report title.
- Name of Contractor and Contract reference number.
- Reporting period.
- Report date.
- Name, qualifications and signatures of report author(s) and reviewer(s) and sign-off statement(s).
- Contractor document number.
- Document revision number and revision history or record of issue table.
- Table of Contents (for large reports).

Executive Summary Section

The Executive Summary Section should contain the following information:

- Statement that the report was prepared in accordance with the Site C Project CEMP, approved site- and activity-specific EPPs, and relevant permits and authorizations.
- Summary of primary construction activities conducted during the reporting period.
- Summary of environmental monitoring effort (e.g., inspection dates, frequency, duration, personnel) delivered during the reporting period.
- List of approved EPPs under which the construction activities and environmental monitoring effort applied to.
- Summary of significant communications that relate to environmental management processes (e.g., environmental workshop presentation dates and attendance, environmental orientation sessions for new workers dates and attendance, environmental tailboards summaries, key meetings).

Summary of Environmental Monitoring Inspections and Findings Section

The Summary of Environmental Monitoring Inspections and Findings Section should contain the following information:

- Summary of key findings and implemented mitigation measures related to the following topics of environmental protection and management which are listed in an order that aligns with the CEMP. Repeat these headings in every report in the same order, so that readers consistently know where to look for information in each report. If a particular topic or sub-heading is not relevant due to scope of work, indicate “not applicable” under that topic or sub-heading rather than not including any reference to that topic or sub-heading.
 - Air Quality Management
 - (e.g., summary of air quality monitoring results)
 - Blasting Management
 - (e.g., summary of mitigation measures implemented to avoid causing harm to fish and fish habitat during blasting activities near flowing water)
 - Contaminated Sites Management
 - (e.g., summary of contaminated soils encountered during excavation)
 - (e.g., summary of contaminated soil chemical analysis results)
 - (e.g., summary of environmental incidents that resulted in soil contamination)
 - Erosion Prevention and Sediment Control Management
 - (e.g., updated copy of erosion and sediment control issues tracking table in accordance with CEMP Appendix I – see attached example table)
 - (e.g., summary of soil erosion prevention and sediment control measures implemented)
 - Fisheries and Aquatic Habitat Management
 - (e.g., summary of mitigation measures implemented to avoid causing harm to fish and fish habitat)
 - (e.g., results of fish sampling, site isolation, fish salvage and relocation activities)
 - Fuel Handling and Storage Management
 - (e.g., summary of fuel storage area inspections findings)
 - Groundwater Protection
 - (e.g., summary of ground water protection measures implemented during drilling, excavating, drill hole decommissioning)
 - Hazardous Waste Management
 - (e.g., summary of how hazardous wastes were segregated, stored, handled, transported and disposed)
 - Heritage Resources Management
 - (e.g., summary of how heritage resources protection requirements were achieved)
 - Ice, Snow and Extreme Cold Management
 - (e.g., summary of environmental mitigation measures implemented to address winter weather)
 - Noise and Vibration Management
 - (e.g., summary of mitigation measures implemented to lessen the impact of noise that could disturb residents)
 - Soil Management, Site Restoration and Revegetation
 - (e.g., summary of mitigation measures implemented to manage soil, site restoration and revegetation requirements)

- Spill Prevention and Response
 - (e.g., summary of vehicle and equipment inspections findings)
 - (e.g., summary of spill kit and drip tray inspections findings)
 - (e.g., summary of environmental incidents resulting in hydrocarbon releases into the environment)
 - (e.g., summary of environmental incidents resulting in external reporting such as those that trigger the Spill Reporting Regulation)
- Surface Water Quality Management
 - (e.g., summary of SEV monitoring results, statement as to whether there were exceedances, and confirmation that all required monitoring was completed.
 - (e.g., summary of water quality monitoring results)
 - (e.g., summary of measures implemented to address concrete works near water)
 - (e.g., summary of water management measures, such as diversions and site isolation, employed to protect surface water quality)
- Vegetation and Invasive Plant Management
 - (e.g., summary of measures implemented to minimize the dispersal of invasive plant species)
- Waste Management
 - (e.g., summary of waste reduction, segregation, disposal, and reuse and recycling measures, including summary of project wide efforts to ensure compliance with waste management requirements, waste bin inspections)
- Wildlife Management
 - (e.g., summary of wildlife surveys and protection measures implemented)
 - (e.g., summary of wildlife observations, den and nest sweeps; disturbances and mortalities)
- Restricted Activity and Work Avoidance Zones Management
 - (e.g., summary of compliance with established work avoidance zones for sensitive vegetation, wetlands, and heritage sites)
- Acid Rock Drainage and Metal Leaching Management
 - (e.g., site wide summary of ARD/ML monitoring results)
 - (e.g., summary of data logger results for hourly measurements of pH, turbidity and conductivity in each PAG contact water sediment pond)
 - (e.g., summary of results from analysed water samples from each PAG containing RSEM)

Summary of Emerging, Identified, Outstanding and Resolved Environmental Management Issues and non-Compliances Section

The Summary of Emerging, Identified, Outstanding and Resolved Environmental Management Issues Section should contain the following information:

- Summary of anticipated environmental issues identified during the reporting period (e.g., upcoming increased risk work windows for nesting birds or breeding amphibians).
- An Environmental Issues Tracking Table that:
 - Lists newly identified, outstanding or currently active, and recently resolved environmental management issues and non-conformances with an EPP or with the CEMP
- For EPP or CEMP non-conformances and any incidents, lists the event details, corrective action plan, due date for the corrective action and ongoing status updates

- Is maintained for the duration of construction activities and updated on a continual basis.
- Has issue or row in the table identified as a unique “Issue Number”. Issues that were reported as being resolved in one weekly report would not need to be repeated in subsequent report tables.
- Photographs that represent examples of environmental management issues and their management. Each photograph should include the date the image was taken, the location and a short description.

Appendices Section

The Appendices Section should contain the following information:

- Copies of completed environmental monitoring inspection forms that are either issue specific or EPP specific.
- Copies of raw data collected, such as those from measurements of surface water quality or soil sampling analyses.
- Copies of attendance records for environmental workshops, environmental orientations, and environmental tailboards.

Site C Clean Energy Project
Weekly Environmental Monitoring Report

Contractor: AB Site C Dam Environmentally Friendly Ground Haulers JV.
Contract Number: RFPQST-23

Reporting Period: October 24 – 30, 2016
Date Prepared: October 31, 2016
Revision No. 0
Document No. XZY-4321

Prepared By: *Signature*
Kelly Alphabet, B.Sc., R.P.Bio., P.Geo.

Reviewed By: *Signature*
Sammy Letters, M.Sc. R.P.Bio., R.P.F.
Confirmation statements associated with sign-off

EXECUTIVE SUMMARY

This weekly environmental monitoring report describes how environmental management issues were identified and managed during site preparation of Area 51 Laydown and Rainbow Quarry.

During the reporting period of October 24 – 30, 2016, AB Site C Dam Environmentally Friendly Ground Haulers continued site preparation activities at Area 51 Laydown and Rainbow Quarry in accordance with the environmental requirements specified in the Site C Project CEMP and the following approved Environmental Protection Plans:

- Area 51 Environmental Protection Plan (Rev 3.0)
- Rainbow Quarry Environmental Protection Plan (Rev 4.0)

Primary construction activities conducted during the reporting period include the following:

Area 51 Laydown

- Stripping and stockpiling of segregated topsoil;
- Grubbing of stumps and roots; and
- Preliminary site grading.

Rainbow Quarry

- Installing of security fencing; and
- Establishing perimeter drainage.

Construction activities were monitored for compliance with the project's environmental requirements by qualified professionals, who delivered environmental orientations to new workers, presented environmental topics at daily tailboard meetings, conducted daily inspections of work areas, helped implement mitigation measures to avoid or minimize the potential for adverse environmental effects and documented the results of inspections and water quality measurements.

During the reporting period there were no exceedances of surface water quality thresholds for the protection of aquatic life and the prevalence of dry weather assisted in the control of soil erosion and off site sediment transport.

The following report sections provide further details about how environmental management issues were managed during construction activities.

1.0 SUMMARY OF CONSTRUCTION ACTIVITIES AND ENVIRONMENTAL MONITORING EFFORT

Work Area & Construction Activities	Environmental Monitor	Inspection Frequency & Dates
Area 51 Laydown		
Stripped and stockpiled topsoil	Kelly Alphabet	Weekly – Oct 25
Grubbed and graded	Kelly Alphabet	Weekly – Oct 26
Rainbow Quarry		
Installed security fencing	Kelly Alphabet	Weekly – Oct 23
Established perimeter drainage	Kelly Alphabet	Weekly – Oct 23

1.1 Summary of Approved EPPs

- List the approved EPPs, including revision number and date, applicable during the Reporting period

2.0 SUMMARY OF ENVIRONMENTAL MONITORING COMMUNICATIONS

2.1 Environmental Workshops and Tailboards

- Delivered two environmental workshops to newly hired Senior Environmental Coordinator and Environmental Monitors (see attached attendance record).
- Contributed environmental information about need to segregate various waste types and recyclable materials during daily tailboard meeting at Rainbow Quarry on October 23 (see attached Tailboard form).

2.2 Meetings with Construction Managers and Work Supervisors

- Participated in weekly construction contractor planning meeting on October 26. Raised issues about need to order additional erosion and sediment control materials for Area 51 Laydown, and additional spill response supplies for Rainbow Quarry.
- Participated in October 24 meeting to review approved Care of Water Plan Rev. 3 for Peace River Bridge construction.

2.3 Meetings with Regulatory Agencies and External Auditors

- Participated in unplanned FLNRO Compliance Officer inspections of Rainbow Quarry on October 23. No environmental issues identified.

3.0 SUMMARY OF ENVIRONMENTAL MONITORING INSPECTIONS AND FINDINGS

3.1 Air Quality Management

- Identified three vehicles idling with no occupants or the need to defrost windows. Communicated need to avoid unnecessary idling to site foreman.
- Water used to suppress dust on Rainbow Quarry haul road (see attached water usage summary data table).

3.2 Blasting Management

- Not applicable during the reporting period.

3.3 Contaminated Sites Management

- No newly identified contaminated sites. Contaminated soils temporary storage bin is labelled, properly sealed for protection from rain and at 50% capacity.

3.4 Erosion Prevention and Sediment Control Management

- Constructed sediment retention pond and perimeter drainage ditches as per Care of Water Plan at Area 51 Laydown.
- Installed ten rock check dams in north and south perimeter drainage ditches at Area 51 Laydown.
- Removed accumulated sediment from within culvert inlet sumps at Rainbow Quarry.

3.5 Fisheries and Aquatic Habitat Management

- Maintained fish exclusion fencing around south abutment and Pier 3 of Peace River Construction Bridge.
- Conducted daily water quality monitoring to TSS, pH, conductivity and turbidity at Peace River Construction Bridge (see attached WQ data tables).

3.6 Fuel Handling and Storage Management

- Weekly inspection confirmed that fuel storage areas are compliant with EPP requirements (see attached daily environmental monitoring checklist).

3.7 Groundwater Protection

- Table providing details and summary results from all water quality monitoring that occurred during the week

3.8 Hazardous Waste Management

- Hazardous waste disposal hauler scheduled to remove temporarily stored contaminated soils in late November. Will include copy of waste disposal manifest in weekly environmental monitoring report when documentation is received.

3.9 Heritage Resources Management

- Confirmed that protected archaeological site within 500 m of Rainbow Quarry has functional NO WORK exclusion fencing.

3.10 Ice Management

- Not applicable during the reporting period.

3.11 Noise and Vibration Management

- Not applicable during the reporting period.

3.12 Soil Management, Site Restoration and Revegetation

- Temporary topsoil stockpiles at Area 51 Laydown have been covered in plastic sheeting to prevent erosion.

- Site restoration and revegetation at Temporary Substation scheduled to occur during March 2017.

3.13 Spill Prevention and Response

- Inspections of spill kit contents at Rainbow Quarry identified insufficient back up supplies. Submitted request for additional supplies to Construction Manager.
- Daily inspections of vehicles and equipment identified no hydrocarbon leaks (see attached daily environmental monitoring inspection checklists).
- Summary of overall inspection of vehicle and equipment fleet results including vehicle/equipment ID, last inspection date, upcoming inspection date, inspection results and notes on equipment maintenance and resolution of leaks and excess grease

3.14 Surface Water Quality Management

- Conducted daily water quality monitoring to TSS, pH, conductivity and turbidity at Peace River Construction Bridge (see attached WQ data tables).
- Table providing details and summary results from all water quality monitoring that occurred during the week

3.15 Vegetation and Invasive Plant Management

- Temporary topsoil stockpiles at Area 51 Laydown have been covered in plastic sheeting to prevent erosion.

3.16 Waste Management

- Not applicable during the reporting period.

3.17 Wildlife Management

- No reported wildlife observations or issues identified during the reporting period.

3.18 Restricted Activity and Work Avoidance Zones Management

- Not applicable during the reporting period.

3.19 Acid Rock Drainage and Metal Leaching Management

- Unanticipated PAG rock excavated at Area 51 Laydown. Qualified professional assessing volume, rock chemistry and management options. Implemented EPP Care of Water Plan to reduce contact with flowing water. Area barricaded as temporary no work zone.

4.0 EMERGING, IDENTIFIED, OUTSTANDING AND RESOLVED ENVIRONMENTAL MANAGEMENT ISSUES

- Onset of winter weather will trigger need to implement approved Snow and Ice Management Plan at all active construction sites.
- Onset of winter weather may result in increased potential for small mammals to den within piles of wood waste near Area 51 Laydown.

Environmental Issue, Non-conformance, Incident and Corrective Action Summary Table

Issue No.	Environmental Issue/Non-Conformance and Location	Date Identified	Description of Environmental Issue and Corrective Action Plan	Due Date	Date Completed
1	Active bird nest at Area 123	Aug. 2, 2016	An active bird nest was identified during site clearing by equipment operator. A 30 m no work buffer was established and checked weekly. Nest confirmed to be inactive by environmental monitor; buffer removed.		
2	20 L diesel spill at CBA Maintenance shop at Rainbow Quarry	Oct. 16, 2016	Small generator fuel container driver over. Spill pads used to clean up fuel, impacted soil excavated and placed in plastic-lined contaminated soil bin. Copies of hazardous waste disposal manifests to be included in weekly environmental monitoring report when available.		
3	Unanticipated PAG rock excavated at Area 51 Laydown	Oct. 17, 2016	Qualified professional assessing volume, rock chemistry and management options. Implemented EPP care of water plan to reduce contact with flowing water. Area barricaded as temporary no work zone.		

5.0 PHOTOGRAPHS

6.0 APPENDICES

6.1 Environmental Monitoring Inspection Checklists

6.2 Environmental Monitoring Data Tables

6.2.1 Erosion and Sediment Control Issues Tracker Table

6.2.2 Water Useage Summary Table

6.3 Environmental Incident Reports

6.4 Area 51 Laydown EPP Specific Information

6.5 Rainbow Quarry EPP Specific Information

Appendix N Bird Nest Survey Guidance

Minimizing the risk to active bird nests in the Site C Clean Energy Project area



11 September 2020

Report prepared by:
Strategic Resource Solutions (SRS)
Victoria, BC

Table of Contents

1.0 OVERVIEW	1
2.0 BIRD NESTING RISK ASSESSMENT PROCESS (BNRA).....	2
3.0 BIRD NESTING SURVEY GUIDANCE	3
4.0 NEST BUFFERS	4
Appendix 1. Bird Nesting Periods.....	7
Appendix 2. Qualifications of Qualified Environmental Professionals (QEP).....	9
Appendix 3. Responsibilities.....	10
Appendix 4. Bald Eagle Nest Assessment Methodology	12
References	15

1.0 OVERVIEW

This document is a revision of the previous bird nesting survey methodology developed for the BC Hydro Site C Clean Energy Project (Manning et al. 2016) and replaces that document.

The British Columbia *Wildlife Act* (Section 34) (Province of BC 1996) and the federal *Migratory Birds Convention Act (MBCA)* (Section 5[9]) (Government of Canada 1994a) and attendant Migratory Birds Regulations (Government of Canada 1994b) provide legislation that prohibits the disturbance or destruction of a bird, its nest, or eggs. The federal *Species at Risk Act (SARA)* (Government of Canada 2002) provides similar protection for bird species listed on Schedule 1 of the Act, as well as their 'residence' or nesting habitat.

This document describes the methodology for assessing the presence of active bird nests and provides guidelines for minimizing risk of damage or disturbance to active nests (i.e., incidental take) for implementation at the BC Hydro Site C Clean Energy Project site and adjacent areas impacted by this project. The methodology was developed using active nest avoidance guidance from CWS (Environment Canada 2016a), provincial Best Management Practices (BC MFLNRO 2013 and 2014), and bird nest survey methodologies produced for similar development projects in British Columbia (BC EAO 2018). BC Hydro's bird nest survey methodology is intended to reduce the likelihood of non-compliance with the *Wildlife Act*, *MBCA* and *SARA* in relation to work activities at the Site C Clean Energy Project. The *MBCA* prohibits the destruction of migratory bird species and their nests. The methodology and guidelines described in this document are intended to minimize the likelihood of non-compliance with provincial and federal regulatory protections for migratory birds and their nests. Assessment of risk to birds or their nests is required, regardless of time of year. If there is deemed to be risk, then nesting activity surveys or other appropriate avoidance or mitigation measures should be implemented.

A bird nesting risk assessment and appropriate avoidance or mitigation strategies (typically disturbance setback buffers around nests) are required for all types of work that could potentially disturb or destroy bird nests (e.g., construction and land clearing activities, land surveying, fish and amphibian salvage, archaeological investigations, removal or changes to existing building structures, and movement of previously idle heavy equipment). Any change or increase in anthropogenic disturbance near active nests has the potential to disturb nesting birds and result in nest abandonment, even if the nests themselves are not physically impacted.

Professional reliance is very important in the assessment and implementation of effective strategies for avoiding impacts to birds and their nests. The high variability in seasonality of bird nesting (see Appendix 1) as well as the complexities of breeding bird biology, result in many challenges for creating effective nesting activity survey and monitoring strategies. Experienced observers must be utilized for the surveys, directly supervised by an onsite Qualified Environmental Professional (hereinafter referred to as QEP) who has particular expertise in the biology of native bird species. See Appendix 2 for a description of appropriate QEP qualifications.

It is the responsibility of all persons on site to strive to maintain compliance with bird and bird nest protection legislation (see Appendix 3).

2.0 BIRD NESTING RISK ASSESSMENT PROCESS (BNRA)

This section describes the work flow process for assessing bird nesting risk, conducting bird surveys, implementing avoidance or mitigation strategies, and communications/reporting.

2.1 Bird Nesting Risk Assessment (BNRA) Workflow

1. Project Site Assessment

Site assessment provides a body of information useful for implementing effective survey and mitigation strategies. Prior to a field visit, several office exercises should be conducted; review the bird survey methodology (this document), the Construction Environmental Management Plan (CEMP), and the environmental features map with associated GIS files. Completion of these tasks will assist in determining potential onsite issues related to SARA or other bird protection legislation/regulations, and potential conflicts with bird nesting habitats. A site visit by a QEP, consisting of a walk-through of the project area, should also be conducted to evaluate the likely occupancy patterns (temporal and spatial) of various bird species.

2. Conduct Bird Nesting Activity Surveys

Bird nesting activity surveys will be conducted and supervised by onsite QEP(s). Survey summaries will report, at a minimum, rationale for survey effort and coverage, geographic coordinates of nest buffer centroids, description and rationale for buffers, plus recommended avoidance or mitigation measures (if applicable). Section 3.0 of this document provides guidance for conducting bird nesting activity surveys.

3. Issue a Bird Nesting Risk Assessment (BNRA) Report

Findings and recommendations from bird nesting activity surveys will be communicated/disseminated upon completion (on a daily basis if necessary) to the project distribution list that typically includes appropriate contractor main contacts, project foremen on site, BC Hydro environmental manager or construction manager(s), other BC Hydro environmental staff, and internal and external environmental monitors. These reports will include information as follows:

- Brief summary of the Project Site Assessment and Bird Nesting Survey Plan (Step 1 above).
- Description of areas where the risk of damage or disturbance to active nests or incidental take, is deemed minimal. Such locations will be considered “Free to Work” areas.¹
- Summary of survey results, including timing of surveys, intensity of survey effort, notable existing constraints (if any), details of any actual or projected bird nesting issues, and description of nest buffer locations (Step 2 above).

¹ It should be noted that areas considered “Free to Work” do not have zero risk of damage or disturbance to active nests that may be present in those areas. However, sufficient survey effort and applicable avoidance or mitigation strategies have been implemented to minimize, as far as practicable, the risk of nest disturbance, damage or incidental take.

- Clearance for project work to commence, continue or resume. Included will be the date and time range for the issued work clearance, plus any avoidance, monitoring, or mitigation strategies or requirements related to the clearance.

3.0 BIRD NESTING SURVEY GUIDANCE

This section describes best practices for conducting bird nesting activity surveys for the Site C Clean Energy Project. The methodology in this document provides guidance for conducting bird nesting activity surveys with minimal intrusion and associated risk of nest disturbance. The primary focus of the surveys is to locate probable nest locations, rather than finding actual nests. Probable nest locations are determined by keying in on significant evidence indicators such as flight displays, bird song, drumming, alarm calls, pair bonding, nest construction, food deliveries and cryptic movements to/from a likely nest site.

The following nesting activity survey approach is recommended for areas where work activities are anticipated during the nesting season. Appendix 1 describes nesting periods for various bird species groups.

1. A combination of nesting activity surveys and work activity monitoring is the most effective way to avoid or minimize the risk of nest damage, disturbance or incidental take.
2. Crews will survey the work activity area in spatial and temporal intensity as determined by the QEP. A QEP will be on each survey team and will direct survey efforts for a given location.
3. A minimum of one survey is required if bird nesting is anticipated. Additional nesting activity surveys will often be necessary, particularly in the following circumstances:
 - During periods of high nesting activity (generally May through July), surveys should be conducted at least every 3 days in areas that are scheduled to be disturbed by work activities. During peak periods of nest initiation, surveys may be required prior to daily work start-up.
 - Significant weather events (i.e., unseasonable precipitation, low or high temperatures) can damage or destroy nests and impair the ability of adults to care for eggs and young. Birds whose nests fail can rebuild almost immediately if the breeding season is early enough, therefore more frequent surveys may be necessary in order to detect possible new nest locations.
 - Rugged terrain conditions such as steep gullies, bluffs or cliffs, or high vegetation density, may preclude conclusive determination of bird nesting status, thereby necessitating additional surveys.

It is the responsibility of the QEP to determine the overall adequacy of survey effort (i.e., number, frequency and spatial extent of surveys) such that implementation of any avoidance or mitigation measures will minimize the risk of non-compliance with bird protection legislation. In this context, many variables including local weather conditions, seasonality, vegetation characteristics, topography, and local bird species abundance and distribution (e.g., during critical breeding periods new breeding individuals are regularly arriving), all influence the necessity, intensity and effectiveness of bird nesting surveys.

4. In most cases, nest activity surveys will extend to 30 m beyond the work activity boundaries to encompass the most common potential disturbance setback buffers. However, for species such as Pileated Woodpecker and most raptors, larger buffers may be required, thus extending the spatial extent of a survey when nesting of such species is anticipated. Table 1 (Section 4.0) describes recommended minimum nest buffer sizes.
5. Bird nesting activity surveys should not be conducted at freezing temperatures, during more than very light precipitation, and when winds exceed 20 km/h (i.e., > Beaufort Scale 3 ["gentle breeze"]). Inclement weather, particularly precipitation and wind, can severely hamper the ability of observers to detect birds. Additionally, bird surveyors could inadvertently flush birds off nests, leaving eggs or chicks unnecessarily exposed to the elements, and thus potentially cause incidental take.
6. Active nests and probable nest locations must be buffered appropriately (see Section 4.0).
7. To reduce potential operational delays, it is prudent to conduct a first nesting activity survey well in advance of work startup. In many cases, most disturbance setback buffers around nests can be identified during this survey. Implications for construction/clearing can then be communicated to the appropriate persons in advance of work commencement.
8. Work activity monitoring is an effective strategy to help enable a construction/clearing project to move forward while minimizing the risk of nest damage, disturbance or incidental take. Monitoring should be implemented after initial surveys have determined probable nest locations, and when and where it is anticipated that additional nests may be constructed or found after nesting activity surveys have been conducted. When and where monitoring is deemed appropriate by the QEP, construction or clearing activities in those zones should be suspended until documented clearance to resume work has been issued by the QEP. In most cases, especially if there are deemed to be few or no constraints, this can be accomplished by conducting an early morning nesting activity survey along with immediate completion and issuance of appropriate documentation.

4.0 NEST BUFFERS

A disturbance setback buffer, in which no work or disturbance should occur, is usually required when work is anticipated in the vicinity of active or probable nest locations. Buffers should be designed such that any work activities conducted outside of the buffer would be very unlikely to render an active nest ineffective or cause it to become abandoned. Buffers should be conspicuously flagged using an orange and black striped ribbon, which is the standardized site flagging color for indicating an "established bird nest buffer is in place" to minimize risk of inadvertent entry by workers. Attach some additional conspicuous flagging (e.g., white) alongside the orange and black striped ribbon at a location along the buffer periphery. This informational flagging would have the following information written clearly on it: distance (m) and direction (bearing in degrees) to the nest, date that nest buffer was established, and bird species.

4.1 Buffer Configuration

The size and shape of the disturbance setback buffer around a nest depends on various factors, such as site topography, proximity of the nest to naturally open areas, type and amount of surrounding vegetation cover, nesting period and breeding chronology, a particular bird species' sensitivity to disturbance, rareness of the species in the local/regional area, and the type, extent

and duration of work activities that will be occurring adjacent to the buffer. In general, a minimum 30 m radius buffer will be established around active nests or probable nest locations. Table 1 provides recommended minimum nest buffer sizes for various bird species groups. The precautionary principle should be applied when establishing a disturbance setback buffer around a nest; when in doubt, larger is better. In some situations, where work activities do not create a high degree of disturbance, the adaptive buffer size methodology (Section 4.2 below) may be implemented. No work activities that are deemed to be potentially disruptive to nesting birds will be allowed within an established disturbance setback buffer area.

Table 1. Recommended minimum buffer sizes around active bird nests and probable nest locations.

Bird Species ³	Recommended Buffer Size ^{1,2}
Most bird species	30 m radius
Pileated Woodpecker and Common Nighthawk	50 m radius
Bald Eagle	300 m radius ⁴
Other raptors and owls (ground nesters/stick nesters/non-cavity nesters), including Golden Eagle, Osprey, Peregrine Falcon, Northern Goshawk, Great Horned Owl	100 m radius
Trumpeter Swan, Sandhill Crane	200 m radius
Great Blue Heron	300 m radius
Sharp-tailed Grouse leks	2,000 m radius ⁵

4.2 Adaptive Buffer Size Methodology

Under certain site-specific circumstances and with written rationale approved by the QEP, disturbance setback buffer sizes and shapes may be altered from those described in Table 1. The QEP will determine the appropriate site-specific buffer size, shape, configuration and appropriate avoidance or mitigation and monitoring strategies, on a case by case basis.

The following are examples of circumstances in which the Adaptive Buffer Size Methodology may be applied:

¹ Recommended buffer sizes were developed from a combination of sources including: recommended buffer sizes in *Guidelines for Raptor Conservation during Urban and Rural Land Development in British Columbia 2013* (BC MFLNRO 2013); Buffer Zone and Setback Distances Recommendations (Environment Canada 2018b); and *Develop With Care 2014: Environmental Guidelines for Urban and Rural Land Development in British Columbia* (BC MFLNRO 2014).

² Buffer sizes can be altered by the onsite QEP as described in the “Adaptive Buffer Size Methodology”.

³ Golden Eagle, Osprey, Peregrine Falcon, Sandhill Crane and Great Blue Heron have not currently been documented as nesting within the Site C Project Activity Zone.

⁴ This buffer size was increased from a 200 m radius as recommended in the previous version of this Methodology (Manning et al. 2016) and is consistent with the 300 m radius buffer recommended in Appendix 4 and also in Revision 5 of the CEMP (BC Hydro, Oct. 2017).

⁵ Refer to Revision 5 of the CEMP (Oct. 2017, sec. 4.17) for guidance concerning Sharp-tailed Grouse leks.

1. Birds habituated to human activities. Examples include swallows nesting under bridges or on buildings, and birds constructing nests along active roads or in active work areas. Also, for active nests discovered in an active construction zone the CEMP (Oct. 2017, Section 4.17) specifies a minimum 5 m disturbance setback buffer around such nests to protect the nest and allow construction activities to proceed.
2. Some work activities (e.g., land surveying, amphibian salvage, and archaeological excavation with hand tools) may not be highly disruptive to nesting birds. Thus, smaller buffers, as determined by the QEP, may be appropriate in these situations.
3. Where naturally occurring topographic features or vegetation structure (e.g., cliff or large rocky outcrop, steep forested gully or ravine) provide sufficient visual or auditory buffering/shielding around the nest.
4. A mitigation and monitoring plan or strategy is developed and implemented to minimize disturbance effects or impacts on a nesting bird. In most cases this will be a written strategy developed prior to commencement of work activities. However, depending on variables such as unforeseen scheduling or work tasks, a verbal strategy could be developed and communicated directly to work crews onsite by the QEP; this information would subsequently be documented in written format. The following are examples of situations where a mitigation and monitoring plan/strategy may be implemented:
 - Manual clearing, grubbing or minor excavation (using hand tools) is conducted instead of using machinery.
 - Temporary physical barriers (i.e., landscape fabric curtains of sufficient height and length) erected between a bird nest and the work site, thereby providing a visual and auditory shield.

In addition to mitigation to reduce the likelihood of disturbing birds or nests with altered disturbance setback buffers, bird nesting behaviour must be closely monitored under the direction of a QEP to evaluate mitigation effectiveness. Work activities must be halted if a nesting bird shows signs of visible and sustained agitation or is disturbed from the nest. If such disturbance occurs, the QEP will determine an appropriate alternate mitigation strategy to be implemented prior to the resumption of proximal work. This may include the re-establishment of the original nest buffer

Prepared by: Michael G. Shepard (RPBio, QEP), Todd Manning (RPBio, RPF, QEP) and Paul Chytk (RBTech, QEP)
Strategic Resource Solutions (SRS)
Victoria, B.C.

19 March, 2019

Appendix 1. Bird Nesting Periods

Understanding of bird nesting periods is important for both planning of work activities related to the Site C Clean Energy Project and for reducing the risk of non-compliance with bird protection legislation.

Table 2 illustrates bird nesting periods and least risk windows at Site C and vicinity, and is a compilation of information derived from the “Peace Region selected terrestrial and aquatic wildlife least-risk windows” (BC MFLNRO 2011); “A compendium of wildlife guidelines for industrial development projects in the North Area, British Columbia” (BC MFLNRO 2014a); Environment and Climate Change Canada’s “General nesting periods of migratory birds in Canada” (Zone B5; ECCCC 2017); and recent supplemental observations of bird nesting chronology at Site C (Strategic Resource Solutions unpub. data 2015-2016). The **Critical Nesting Period** (shaded red) is the time period in which the majority of nesting activity occurs, the **Caution Nesting Period** (shaded yellow) encompasses times when some of the bird population may be nesting, and the **Exceptions Nesting Period** (shaded green) is when very few birds are expected to be nesting. A few bird species (e.g., White-winged Crossbill) can nest at any time of year. Thus, these nesting periods represent “timing windows” which can generally be correlated with the probability/likelihood of bird nesting activity and also the risk of adversely impacting bird breeding activities (i.e., nest abundance and potential risk of impacting nesting activity are higher during the critical and caution nesting periods).

Consequently, to reduce the likelihood of non-compliance with bird protection legislation and avoid or minimize damage to active bird nests, a bird nesting risk assessment will need to be conducted by a QEP. In most cases this will include a site visit to verify local breeding activity or nesting status at that time and in relation to onsite conditions (e.g., bird species presence/absence and behavior, proximity, type and duration of planned work activities); based on this visit and if there is deemed to be a higher likelihood of active nesting, then appropriate bird nesting activity surveys and associated avoidance or mitigation strategies will be required (as per Section 3.0 and Section 4.0 of this document).

Table 2. Peace Region bird nesting periods.¹

	Jan	Feb	Mar	Apr	May	Jun	Jul	Aug	Sep	Oct	Nov	Dec
Bald Eagle ²	Green	Yellow	Red	Red	Red	Red	Red	Red	Yellow	Green	Green	Green
Other Raptors	Green	Yellow	Yellow	Red	Red	Red	Red	Yellow	Green	Green	Green	Green
Common Raven	Green	Green	Yellow	Red	Red	Red	Red	Yellow	Green	Green	Green	Green
Sharp-tailed Grouse	Green	Green	Yellow	Red	Red	Red	Red	Yellow	Green	Green	Green	Green
Other Grouse	Green	Green	Green	Yellow	Red	Red	Red	Yellow	Green	Green	Green	Green
Trumpeter Swan	Green	Green	Green	Red	Red	Red	Red	Yellow	Green	Green	Green	Green
Waterbirds, Shorebirds	Green	Green	Green	Yellow	Red	Red	Red	Red	Yellow	Green	Green	Green
Woodpeckers, Chickadees	Green	Green	Green	Yellow	Red	Red	Red	Yellow	Green	Green	Green	Green
Other Songbirds	Green	Green	Green	Green	Yellow	Red	Red	Red	Yellow	Green	Green	Green
Critical			Caution					Exceptions				
Critical Nesting Period			Caution Nesting Period					Exceptions Nesting Period				

¹ The timeframes in Table 2 should be used as a general guideline. Local weather conditions and timing of bird movements will vary across regions and years. Seasonal weather, annual abundance of forage resources, and other variables such as overwintering conditions (i.e., for migratory species) can all influence seasonal arrival, nest construction times, and potentially local annual species diversity and abundance. In particular, White-winged Crossbills can nest at any time of year. This species is highly unpredictable in occurrence, with numbers in the Peace River region varying from a few individuals to many thousands. Crossbills target spruce stands for food resources and nesting sites.

² Refer to Appendix 4 for additional information on assessing Bald Eagle nests and breeding activity.

Appendix 2. Qualifications of Qualified Environmental Professionals (QEP)

The CEMP (2017) defines a Qualified Environmental Professional (QEP) as “an applied scientist or technologist who specializes in a relevant applied science or technology”. In the context of this document, a QEP is someone who specializes in the applied science of biology and has the necessary knowledge, skills, field experience and qualifications relevant to native bird fauna and their habitats in British Columbia. In this context, a QEP must:

- a) Be able to accurately identify native bird species using field observations including physical appearance, audible calls and songs, and various breeding behaviours. Examples of important breeding behaviours include: flight displays; audible clues such as singing, alarm calls or drumming; pair bonding; nest construction (e.g., carrying sticks or other nesting material, cavity excavation); and other nesting behaviour such as food deliveries and cryptic movements to/from a nest site.
- b) Be familiar with life history strategies, including seasonal habitat use and habitat requirements of native bird species, including federally and provincially listed species-at-risk.
- c) Have demonstrated experience providing management guidance and the implementation of mitigative strategies and procedures in relation to operational site work activities (e.g., vegetation clearing) and associated minimization of risk of damage to native bird habitats and/or their habitat features (e.g., nests, nest trees).

At least one QEP must be actively working on each bird nesting survey and will supervise other survey team members.

Appendix 3. Responsibilities

Guidance from Environment and Climate Change Canada strongly suggests that land and vegetation clearing work conducted at times of year when birds are nesting should be avoided. However, due to the complex nature and timing of many aspects of work at Site C, some work activities cannot be avoided during the active bird nesting season.

It is the responsibility of everyone on site to minimize the risk of damaging or disturbing active bird nests and minimize the risk of incidental take. Ongoing communication by bird survey crews with BC Hydro and contractors is critical to minimizing the risk of incidental take of migratory birds. Written reports and other communication (e.g., onsite morning tail gate meetings, direct messaging to project foremen, etc.) will be completed after each nest survey is conducted (see “Bird Survey Team” roles below).

The roles of various parties can be generally described as follows, but is not an exhaustive list. In this section risk refers to the risk of non-compliance with bird protection legislation.

Qualified Environmental Professional (QEP)

- Thoroughly assess the bird nesting situation, and create site-specific nest buffers and avoidance or mitigation and monitoring strategies as necessary to minimize risk.
- Document and communicate the results of bird nesting activity surveys to project foremen, environmental monitors, and environmental or project supervisors. Depending on the time of year, location and habitat type, type of construction or clearing activity, and range of bird species involved, the frequency of reporting and communication will vary but could be required on a daily basis.
- Issue stop work orders if deemed necessary by the QEP to avoid non-compliance

Foremen or Project Supervisors

- Communicate findings of the bird survey team to workers (bird survey team can often assist with this task). This should be done as soon as possible following completion of any bird nest survey assessments.
- Abide by on-site constraints or guidance as detailed by the QEP.

Workers

- Abide by on-site constraints or guidance as detailed by the QEP.
- Stop work and contact the onsite QEP if potentially nesting birds are flushed or otherwise disturbed, or if nests are observed.

Reporting Incidental Take and other non-compliance with bird protection legislation

On a large project such as Site C, some degree of non-compliance of bird protection legislation may occur. This may be in the form of a random collision between a vehicle and a bird, or the inadvertent destruction of a previously undiscovered nest. As with all other environmental incidents, incidental take must be reported immediately following the environmental incident reporting requirements described in Section 2.5 of the CEMP. In the event of an Environmental Incident involving incidental take, the most important reporting aspects for contractors are:

- Immediately report all available information regarding the Environmental Incident (e.g., location, nature of incident, potentially affected environment, scale of incident (minor, moderate, severe), etc.) to BC Hydro and the Independent Environmental Monitor;

- Provide to BC Hydro and the Independent Environmental Monitor a written environmental incident investigation report that includes appropriate photo documentation and describes the:
 - Nature of the incident;
 - Environmental resources affected;
 - Root cause(s) of the incident;
 - Immediate actions taken;
 - Preventive and corrective actions taken to control or limit the activity causing the incident, including a time frame for implementation;
 - Communications held with the contractor's employees and with BC Hydro;
 - Communications with the Independent Environmental Monitor or regulatory agencies
- Contractors must implement the identified preventive and corrective actions in the time frame specified.
- The contractor's QEP must confirm in a written report to BC Hydro that the identified preventive and corrective actions have been taken within 5 working days of implementation of each action.

In the event of an Environmental Incident BC Hydro must:

- report internally in accordance with corporate reporting policies and procedures;
- report externally where required by applicable legislation. Reports will be available to Regulators upon request;
- ensure the IEM is notified of the incident, in the event the Contractor failed to do so;
- notify Aboriginal Groups as required.

Appendix 4. Bald Eagle Nest Assessment Methodology

Bald Eagle nests are protected year round (whether occupied or not) under section 34b of the *BC Wildlife Act* (Province of BC 1996). BC Hydro currently holds permits to remove Bald Eagle nests within the Site C Project Activity Zone (FJ14-154018; expires March 31, 2023) that have been deemed by a QEP to be unoccupied³. The permit prohibits removal of Bald Eagle nests between April 1 and July 31. The permit also requires that a QEP confirm nests are inactive prior to their removal between March 1-31 and August 1-September 30.

The following guidance is designed to minimize the risk of adversely impacting active or otherwise protected bald eagle nests if they are adjacent to clearing/construction activities.

1) Consult Existing Resources

Consult the BC Hydro Site C SharePoint Data Room for the most current Bald Eagle nest database to determine the location of known nests within or adjacent to the work area.

2) Bald Eagle Annual Nest Surveys

Conduct aerial (via helicopter) monitoring surveys of Bald Eagle nest surveys along and adjacent to the Peace River between Hudson's Hope and the Alberta border, up major tributaries to the Peace River, around select large lakes on the plateau near the transmission line and along the proposed expanded transmission line right of way (as per Section 5.1 of the CEMP). These surveys are conducted by BC Hydro in May to July annually and are intended to monitor the breeding activity status and nest productivity of Bald Eagle nests in this area.

3) Pre-clearing Bald Eagle Breeding Status Assessment

Eagles are frequently paired and may start to refurbish existing nests or construct new nests by late January, and subsequently occupy these nests by late February. Therefore, between the beginning of the Caution Nesting Period (January 15) and the time of the annual eagle nest aerial survey (May-July), a QEP may need to conduct surveys to assess Bald Eagle breeding activity³ if clearing or construction activities are scheduled within 300 m of any eagle nests. Boat surveys from the Peace River are a cost-effective means of assessing eagle breeding activity along the river corridor. Survey results will be recorded on a BC Hydro Bald Eagle Nest Activity Data Sheet (see below).

In most cases, 300 m nest buffers will be established around active nest trees. However, where active nests are located less than 300 m from existing human disturbance, or in some cases where it is necessary to conduct work activities within 300 m from an active nest, then as per guidance from the CEMP (Section 4.17), a QEP will determine an appropriate site-specific buffer size and monitor the nest for signs of disturbance due to nearby construction activities. The QEP may implement changes to the established buffer based on the results of monitoring

³ Evidence of breeding activity includes adult eagles perched at or near known nest trees, aerial courtship displays, eagles observed carrying or placing sticks and other nest material, adult eagle pairs closely associating, adult eagles standing or sitting on the nest or incubating, and the presence of eggs or young in the nest. An active nest is further defined as one that is determined to be in use for the purpose of breeding.

BC Hydro committed to retain, until after the last nesting season before reservoir filling, bald eagle nests outside the dam construction area that were confirmed active the year that reservoir clearing began (i.e., the "2017 nests"). However, BC Hydro can no longer meet this commitment, and will be removing these 2017 nests between 2020 and 2022. To compensate for removing the 2017 nests sooner than planned, BC Hydro commits to installing new bald eagle nesting platforms in addition to those in its existing bald eagle nest platform program.

or implement mitigation measures to address observed disturbance to breeding activity in accordance with provincial Guidelines for Raptor Conservation (MOE 2013).

Clearing will not be allowed within any disturbance setback buffer around a nest tree (regardless of its size) until a QEP declares the nest unoccupied.

4) **Eagle Nest and Nest Tree Removal**

Prior to the removal of any Bald Eagle nest or nest tree, a QEP must declare the nest unoccupied. Ideally, removal should be conducted between mid-October and early January when the risk of nest occupancy is very low. If removal is to occur between early January and March 31 (i.e., the peak nest occupancy establishment period), daily nest surveys should be conducted for at least 3 days prior to scheduled falling to confirm occupancy status. If the activity status of the nest cannot be confirmed via ground surveys then an aerial reconnaissance over the nest using a helicopter or unmanned aerial vehicle must be made within 3 days prior to tree removal to confirm that the nest is inactive (i.e., not occupied by eggs or eagles). Photo documentation of the nest(s) either from above or another suitable viewing angle will be taken at this time. On the day of nest removal, the QEP will commence nest site monitoring a minimum of one hour prior to arrival of the falling crew, and will monitor potential eagle nest occupancy until the nest tree has been felled. If any occupancy is detected, falling will be delayed until after nesting activity has been completed and the nest has been declared unoccupied by the QEP.

5) **Salvaging Eagle Nests and Feathers**

If any eagle nests are to be salvaged and relocated, if feasible, consider a partial-salvage procedure involving removal of the primary supporting limbs and nest structure (as opposed to falling the entire tree first). In this way the majority of the sticks and some of the supporting limbs can be salvaged with less damage, and be used to aid reconstruction of a substitute nest elsewhere. If partial salvage is not possible, then collect as much of the original nest structure material as possible once the tree has been felled. This material will be used to aid reconstruction of a substitute nest.

Where an eagle nest and nest tree have been felled, all feathers in the eagle nest are to be collected and provided to the Fort St John FrontCounter BC office or the Conservation Officer Service within 30 days of nest removal or destruction. The submission must include the UTM location (NAD83) where the Bald Eagle nest was removed or destroyed, the date and time of nest removal, the number of Bald Eagle feathers recovered, and confirmation of the inactive status of the nest. A receipt is to be obtained from Front Counter BC indicating they have received the collected feathers.

6) **Survey Conditions**

Surveys should be conducted when winds are light to moderate, and not during moderate to heavy precipitation, to maximize the detectability of eagles (i.e., during periods of high winds or precipitation, eagles may be soaring or temporarily roosting elsewhere and may not be seen near the nest tree in question).

7) **Survey Data to be Recorded**

Use *BC Hydro Bald Eagle Nest Activity Data Sheet*, with observations including number and age cohort (adult, immature) of any eagles seen, and any observations that indicate breeding activity (e.g., adult birds perching together, adults carrying sticks or other nest material, nest construction/refurbishing). Also record a GPS track to document the survey route.

Bald Eagle Nest Activity Monitoring Data Sheet

Surveyor name(s):		Surveyor qualifications:		
Company name:				
UTM coordinates of nest:				
Nest ID:		Approx. height (m) of nest:		Tree species:
Planned date of nearby work activities (vegetation clearing, construction):				
Is the nest active:	YES	NO	Comments:	
Record of nest monitoring to determine activity status				
Date nest monitored <small>(dd/mm/year)</small>	Type of monitoring <small>(direct visual, photograph, ground or aerial)</small>	Start time	End time	Observations

References

- BC Environmental Assessment Office (BC EAO). 2018. Project information centre (e-PIC) website. Available at: <https://www.projects.eao.gov.bc.ca/>. [Accessed: 12 Feb 2018].
- BC Hydro. 2017. Construction Environmental Management Plan (CEMP). Site C Clean Energy Project. Rev. 5 DRAFT, Oct. 2017. 84 pp + app.
- BC Hydro. 2016. Construction Environmental Management Plan, Site C Clean Energy Project. Revision 4: July 26, 2016. Available at: <https://www.sitecproject.com/sites/default/files/construction-environmental-management-plan-aug-2.pdf>. [Accessed: 12 Feb 2018].
- BC Ministry of Forests, Lands, and Natural Resource Operations (BC MFLNRO). 2011. Peace Region selected terrestrial and aquatic wildlife least-risk windows - April 2011. Fish, Wildlife, Ecosystems Northeast Region, Fort St. John. BC. 1 pp. Available at: https://www2.gov.bc.ca/assets/gov/environment/plants-animals-and-ecosystems/wildlife-wildlife-habitat/regional-wildlife/northeast-region/best-mgmt-practices/april_2011_least_risk_windows.pdf. [Accessed: 12 Feb 2018].
- BC Ministry of Forests, Lands and Natural Resource Operations (BC MFLNRO). 2013. Guidelines for raptor conservation during urban and rural land development in British Columbia 2013. 143 pp. Available at: http://www.env.gov.bc.ca/wld/documents/bmp/raptor_conservation_guidelines_2013.pdf. [Accessed: 12 Feb 2018].
- BC Ministry of Forests, Lands and Natural Resource Operations (BC MFLNRO). 2014. Develop with care 2014: environmental guidelines for urban and rural land development in British Columbia. Available at: <http://www.env.gov.bc.ca/wld/documents/bmp/devwithcare/#Main>. [Accessed: 12 Feb 2018].
- BC Ministry of Forests, Lands and Natural Resource Operations (BC MFLNRO). 2014a. A compendium of wildlife guidelines for industrial development projects in the North Area, British Columbia. Interim guidance, Nov. 19, 2014. BC Min. For. Lands and Nat. Res. Operations, North Area. Available at: <http://a100.gov.bc.ca/pub/eirs/finishDownloadDocument.do?subdocumentId=9921>. [Accessed: 26 Feb 2018].
- Environment Canada. 2018a. Migratory birds, policy and regulation: avoidance guidelines. Available at: <http://www.ec.gc.ca/paom-itmb/default.asp?lang=En&n=AB36A082-1>. [Accessed: 12 Feb 2018].
- Environment Canada. 2018b. Technical Information Bulletin. Buffer zone and setback distances. Available at: http://www.ec.gc.ca/paom-itmb/default.asp?lang=En&n=8D910CAC-1#_03_1_1. [Accessed: 12 Feb 2018].
- ECCC (Environment and Climate Change Canada). 2017. General nesting periods of migratory birds in Canada. <https://www.ec.gc.ca/paom-itmb/default.asp?lang=En&n=4F39A78F1>. Accessed 15 June 2017.
- Government of Canada. 1994a. *Migratory Birds Convention Act* [S.C. 1994] c. 22. Queen's Printer, Ottawa, ON. Available at: <http://laws-lois.justice.gc.ca/eng/acts/M-7.01>. [Accessed: 12 Feb 2018].
- Government of Canada. 1994b. Migratory Birds Regulations [C.R.C 1994] c. 1035. Queen's Printer, Ottawa, ON. Available at: http://laws.justice.gc.ca/eng/regulations/C.R.C.,_c._1035/index.html. [Accessed 2 March 2018].
- Government of Canada. 2002. *Species at Risk Act* [S.C. 2002] c. 29. Queen's Printer, Ottawa, ON. Available at: <http://laws-lois.justice.gc.ca/eng/acts/S-15.3/page-1.html#h-1>. [Accessed: 12 Feb 2018].

Manning, T., M. Shepard and P. Chytyk. 2016. Methodology to determine the presence of active bird nests. Unpubl. report prep. for BC Hydro, Site C Clean Energy Project, Vancouver, BC. Jan. 14, 2016. 17 pp.

Province of British Columbia (BC). 1996. *Wildlife Act* [RSBC 1996] c. 488. Queen's Printer, Victoria, BC. Available at: http://www.bclaws.ca/civix/document/id/complete/statreg/96488_01 . [Accessed: 12 Feb 2018].